

Ombrea®

Pergolas Bioclimatiques

Pergola Bioclimatique Autoportante 3x4M

Pérgola Bioclimática Autoportante 3x4M / Self-supporting Bioclimatic Pergola

100% Anthracite / *Antracita / Anthracite* : 15-701052

100% Blanche / *Blanco / White* : 15-701076

Lames blanches + cadre anthracite / *Lamas blancas + marco antracita /*
White blades + anthracite frame : 15-712462

Aspect Bois / *aspecto de la madera / WoodLook* : 15-712164

NOTICE DE MONTAGE

INSTRUCCIONES DE MONTAJE / INSTRUCTIONS MANUAL

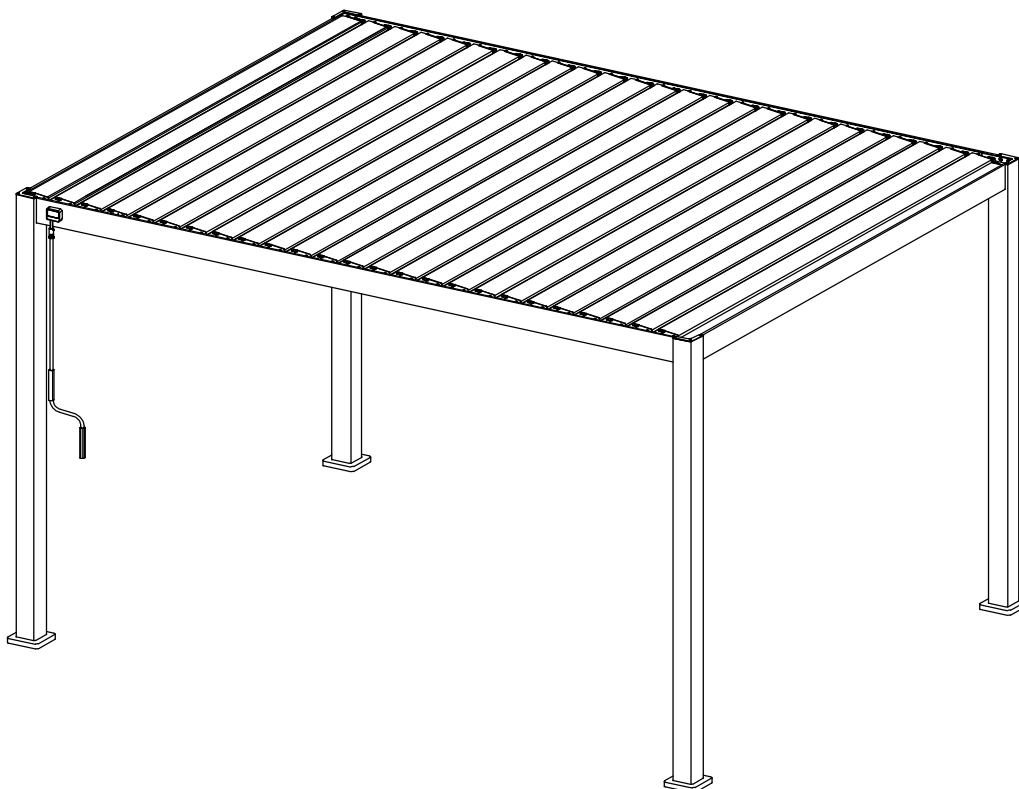

Pergola Bioclimatique Autoportante 3x4M

Notice à conserver pendant toute la durée de vie du produit.

Nous vous demandons de lire attentivement la notice avant de procéder au montage.

L'utilisateur sera responsable des dommages ou blessures causés par une utilisation non conforme.

1. PRÉCAUTIONS D'UTILISATION

Ce produit ne doit pas être utilisé en cas de fortes intempéries : orage, vent violent, grêle, neige. Nous garantissons la résistance de la pergola pour des vents jusqu'à 110 km/h et un poids de neige maximal de 55kg/m².

En cas de vents forts ou de neige, il est vivement recommandé de laisser les lames en position ouverte. En cas d'oubli, il faudra déneiger la pergola afin d'éviter une surcharge importante sur les lames.

Notre pergola peut supporter de fortes pluies, mais, nous ne pouvons pas vous garantir une étanchéité à 100%. En cas d'épisodes climatiques exceptionnels, son étanchéité peut être compromise. Ne pas laisser des produits craignant l'humidité sous la pergola.

Ne pas monter sur le toit ni sur la structure de la pergola.

2. CONSEILS DE MONTAGE

Selon l'emplacement et la surface, les constructions peuvent être soumises à des déclarations de travaux ou de demande de permis de construire. Nous vous invitons à vous rapprocher de votre mairie pour obtenir les informations utiles avant le montage.

Montage du produit :

- 2 à 3 personnes sont nécessaires.
- Ne pas laisser les enfants jouer à proximité de la zone de montage.
- Attention aux risques de pincement.
- Ne jamais serrer complètement les vis avant d'avoir assemblé la partie concernée.
- Toutes les étapes d'assemblage doivent être scrupuleusement respectées.

Aucune modification ne peut être apportée au produit. Les produits modifiés par l'utilisateur ne sont plus couverts par la garantie du fabricant.

Le lieu d'emplacement doit être choisi de manière appropriée. Il est recommandé d'éviter de monter votre pergola face aux vents dominants et sous un arbre.

La pergola doit être montée sur une fondation adéquate stable et nivelée, il est recommandé de l'installer sur une dalle en béton ou sur des plots en béton au niveau de chaque poteau. Nous vous demandons d'ancrer correctement la pergola au sol à l'aide des pièces W.

Si vous souhaitez positionner votre pergola près de votre maison ou d'un bâtiment, nous vous demandons de vérifier la présence de gouttières pour l'écoulement des eaux. La pergola Ombréa® ne pourra pas supporter et garantir une étanchéité parfaite si les eaux de pluie de votre habitation s'y déversent.

En cas de non-respect des recommandations de montage, la garantie ne pourra être appliquée.

3. ENTRETIEN DE LA PERGOLA

Un entretien régulier est nécessaire pour assurer sa longévité et son aspect esthétique, nous recommandons de :

- Laver votre pergola 1 à 2 fois par an à l'eau douce à l'aide d'une éponge ou d'un chiffon. Ne pas utiliser un produit agressif ou un support abrasif.
- Vérifier le serrage des vis régulièrement (au moins 1 fois par an).
- Huiler les pièces de quincaillerie régulièrement (au moins 1 fois par an).
- Veiller à ce que rien ne gêne l'écoulement des eaux dans les gouttières (feuilles, branches...).
- Enlever l'eau qui pourrait stagner autour des pieds de la pergola (soulever les protections).

4. GARANTIE

Ombréa® garantie la disponibilité de ses pièces détachées pendant 2 ou 5 ans (suivant le produit). La garantie ne s'applique que si les consignes de stockage, de montage, d'utilisation, d'entretien sont respectées.

La garantie ne couvre pas :

- L'usure normale inhérente aux produits.
- La perte ou la casse de toute pièce lors du déballage ou de l'installation.
- Le manque de soin raisonnable, la négligence, le vandalisme, les impacts avec des objets étrangers, l'usage de la force, le contact avec des abrasifs, l'esthétique, le démontage, la reconstruction ou relocalisation.
- Les forces majeures : grêle, vents forts, tempêtes, neige, inondations, foudre...

La garantie comporte seulement le remplacement de la pièce détachée ou du produit fourni, à l'exclusion de tous frais et indemnités de quelque nature que ce soit.

Toute demande de garantie doit être formulée au point de vente (magasin ou site internet) dans lequel vous avez acheté votre produit.

5. LISTE DES PIÈCES PAR CARTON

Avant de procéder au montage de votre pergola bioclimatique, il est nécessaire de vérifier que toutes les pièces soient présentes et ne soient pas endommagées.





Toute pièce manquante doit être signalée dans un délai de 30 jours suivant l'achat. Vous pouvez passer par votre revendeur ou faire la demande directement sur notre site sav.comintes.com

Ne pas jeter l'emballage sans s'assurer du bon fonctionnement de la pergola.

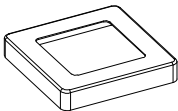
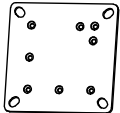
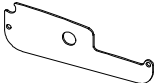
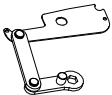
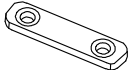
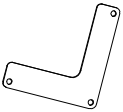
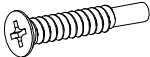
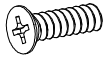
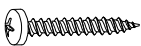

CARTON 1/4 (PIEDS ET QUINCALLERIE)

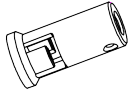
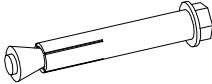
Référence	Schéma	Quantité
A		4

Référence	Schéma	Quantité
I		4
J		4
K		51
L		1
M		52
N		4
O	 ST5.65x45	24
P	 M5x12mm	104
Q	 4.2x25mm	104

Référence	Schéma	Quantité
R	 5.5x19mm	12
S		29
V		1
W	 M8 x 80	16
X		1
Y		2

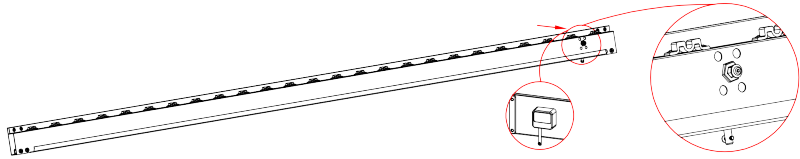
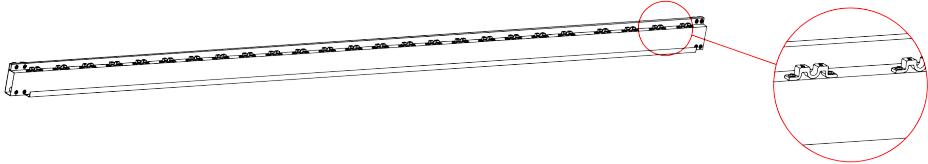
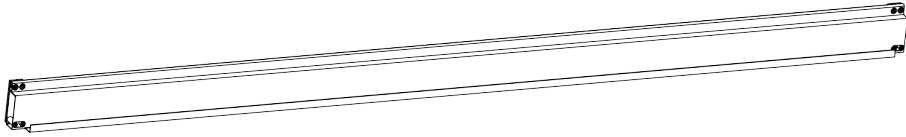
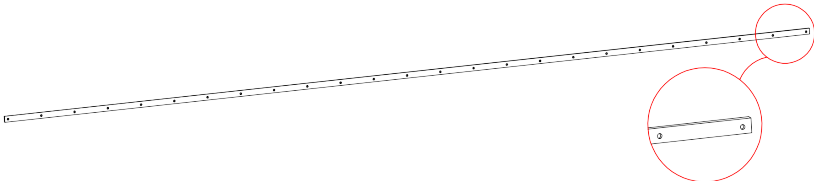
CARTON 2/4 (CADRE SUPÉRIEUR)

Référence	Schéma	Quantité
B1		1
B2		1
C		2
G		1
H		1

CARTON 3/4 (LAMES)

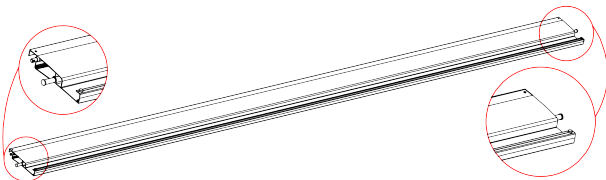
Référence	Schéma	Quantité
D		13

CARTON 4/4 (LAMES)

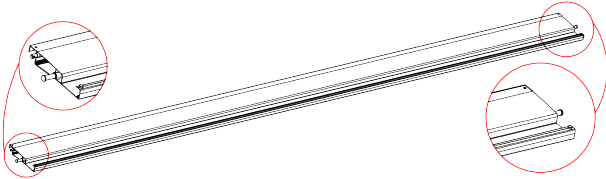
Référence	Schéma	Quantité
D		12

6. MATÉRIEL (NON FOURNI) NÉCESSAIRE POUR LE MONTAGE

- Gants
- Cutter
- Maillet
- Casques de sécurité
- Mètre
- Visseuse électrique
- Perforateur/perceuse
- Escabeau

7. PLAN DE MONTAGE (dimensions en mm)

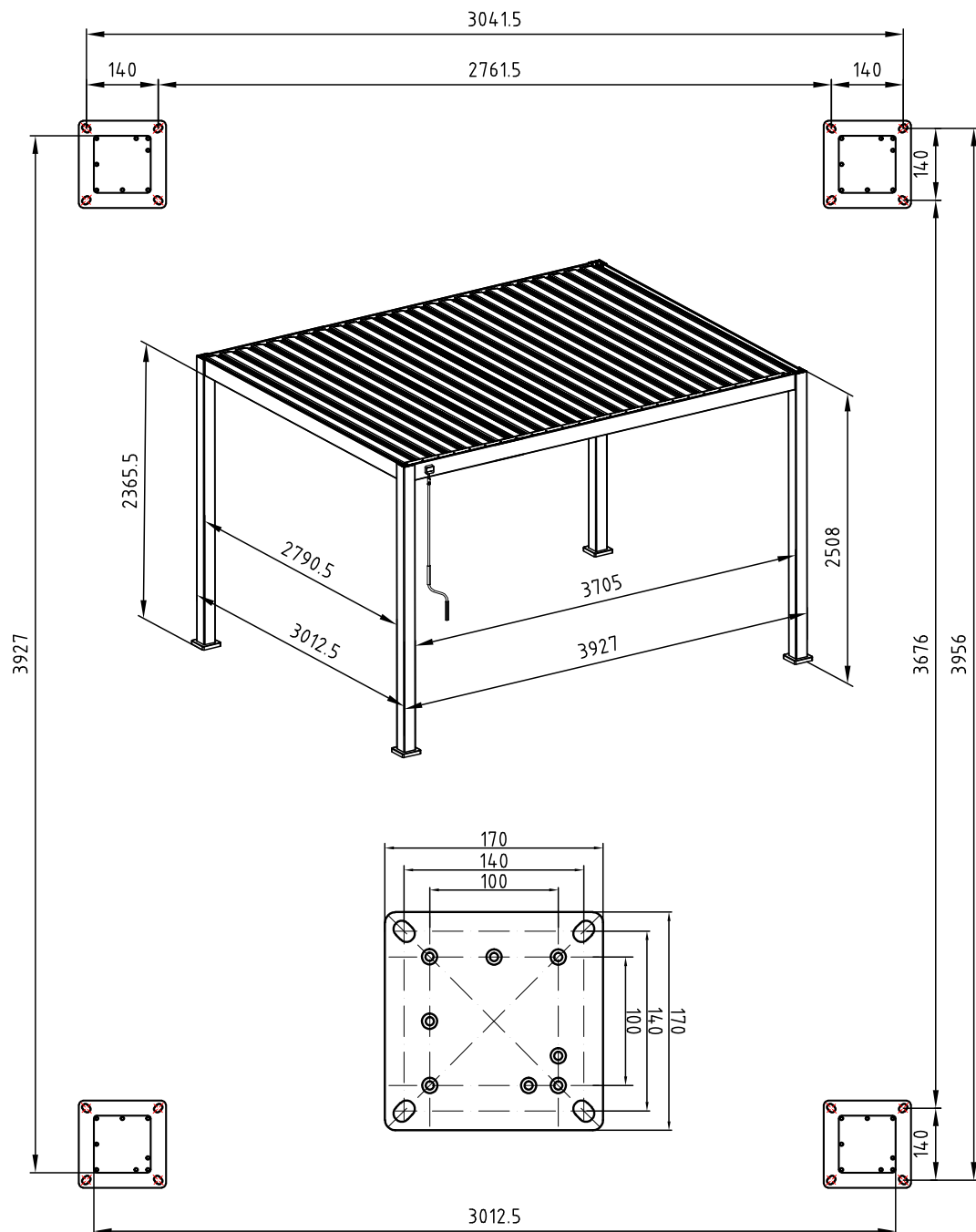

8. ÉTAPES DE MONTAGE

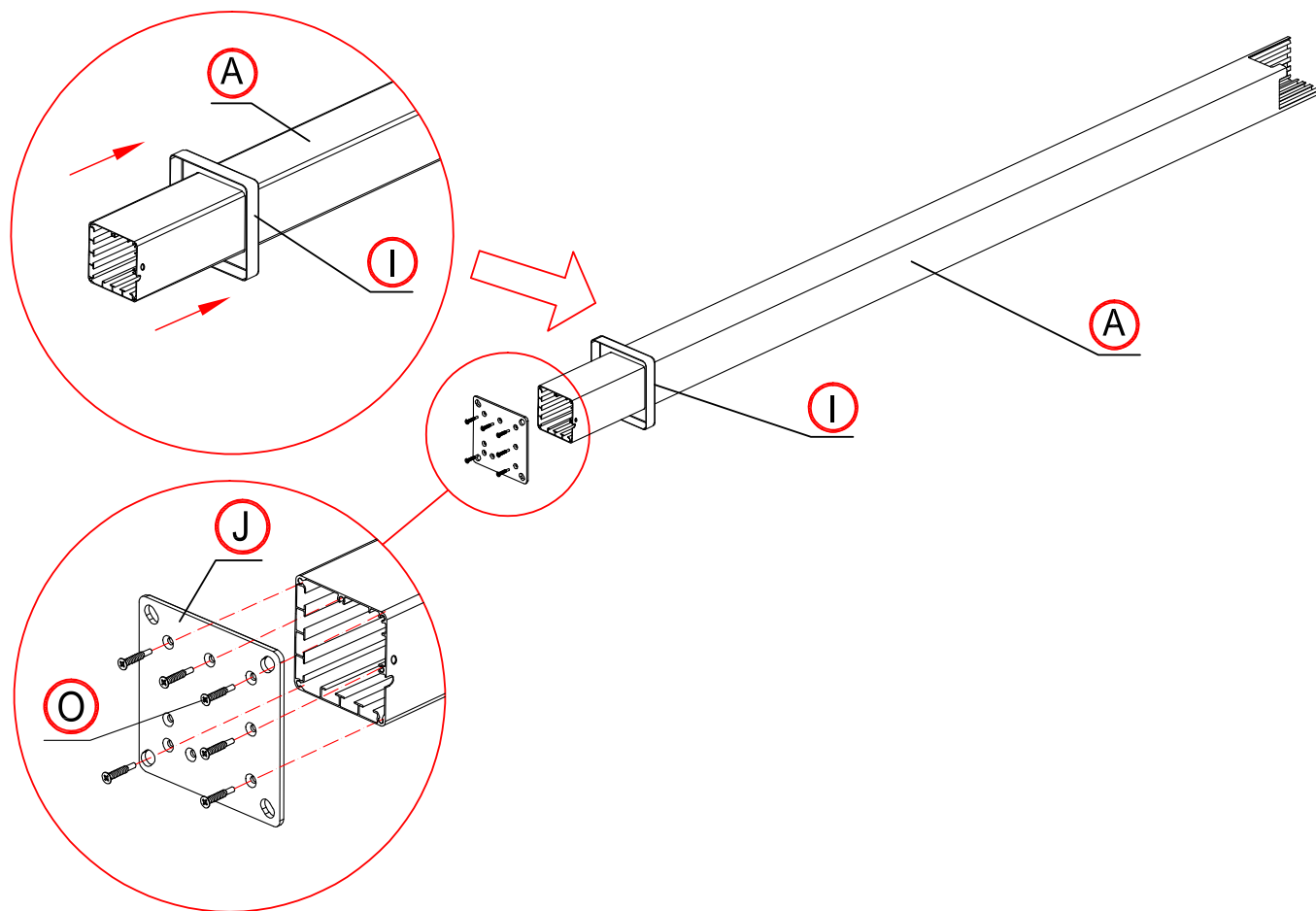

Glisser les caches I sur les 4 poteaux puis positionner les platines J sous les 4 poteaux également.

Afin de ne pas abîmer la peinture, nous vous recommandons de les assembler sur une table ou sur une surface plate et propre.

Fixer les vis O à l'aide d'une visseuse. Commencer par serrer légèrement puis complètement une fois que toutes les vis sont positionnées.

Desserrer les plaques métalliques aux 2 extrémités de la poutre B1 (ne pas les dévisser complètement).

Insérer la poutre B1 dans les poteaux A simultanément des 2 côtés. Les plaques métalliques doivent coulisser dans les rainures des poteaux.

Resserer les plaques métalliques à l'aide de l'outil Y.

Répéter la même opération pour les poutres B2 et C.

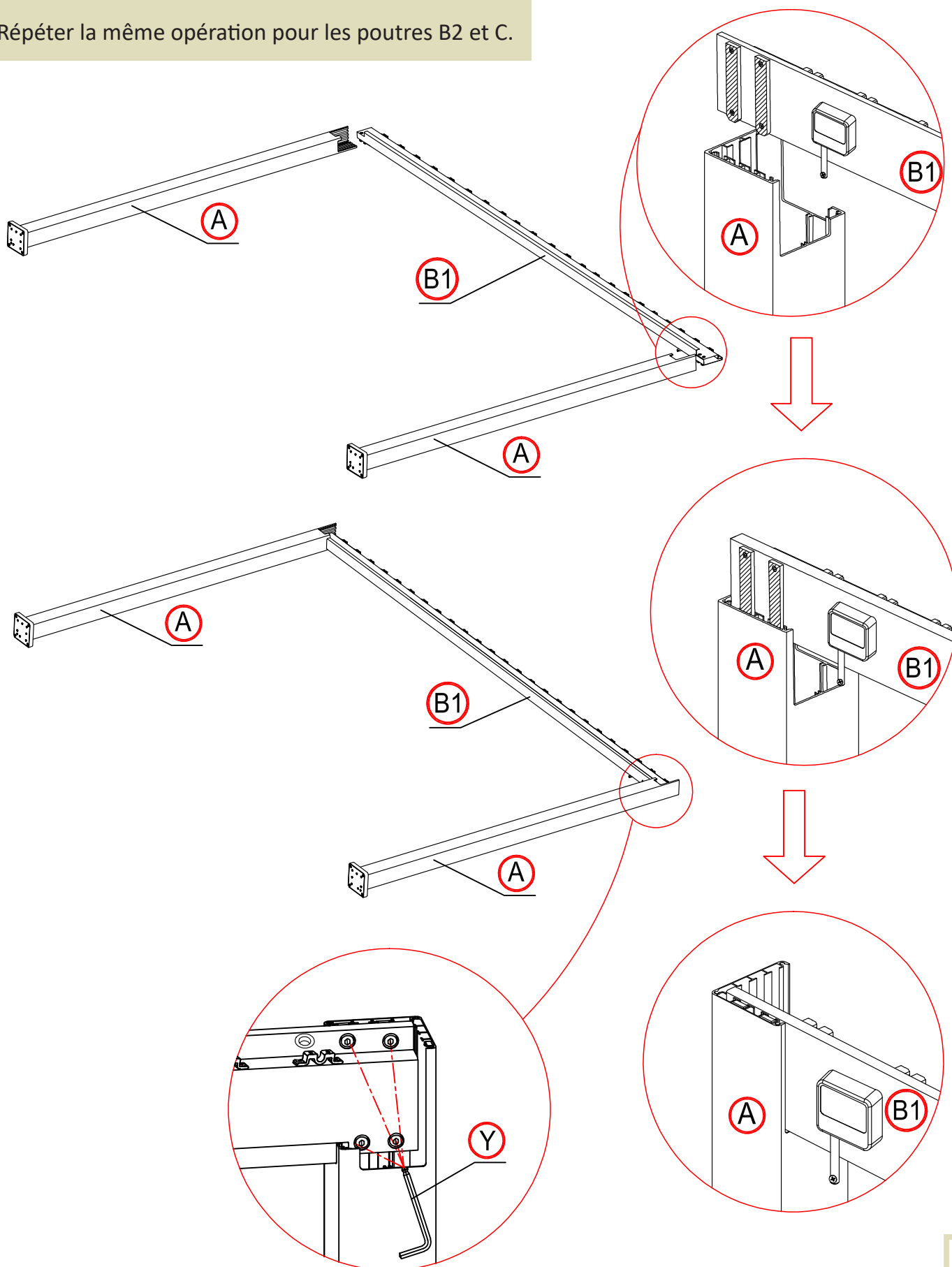

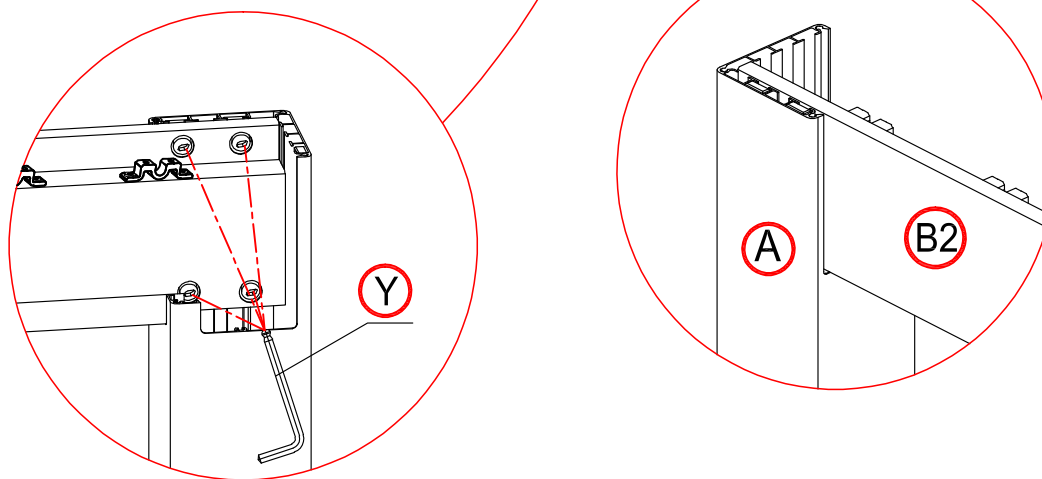
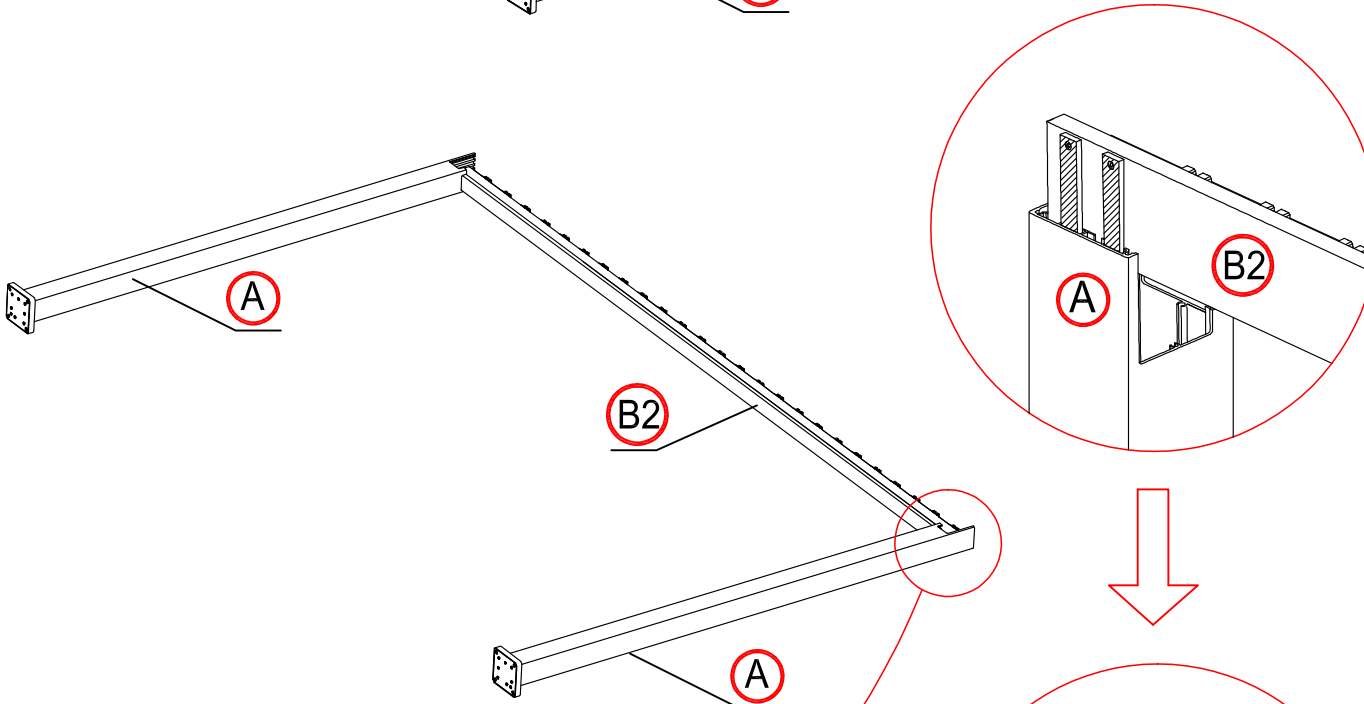
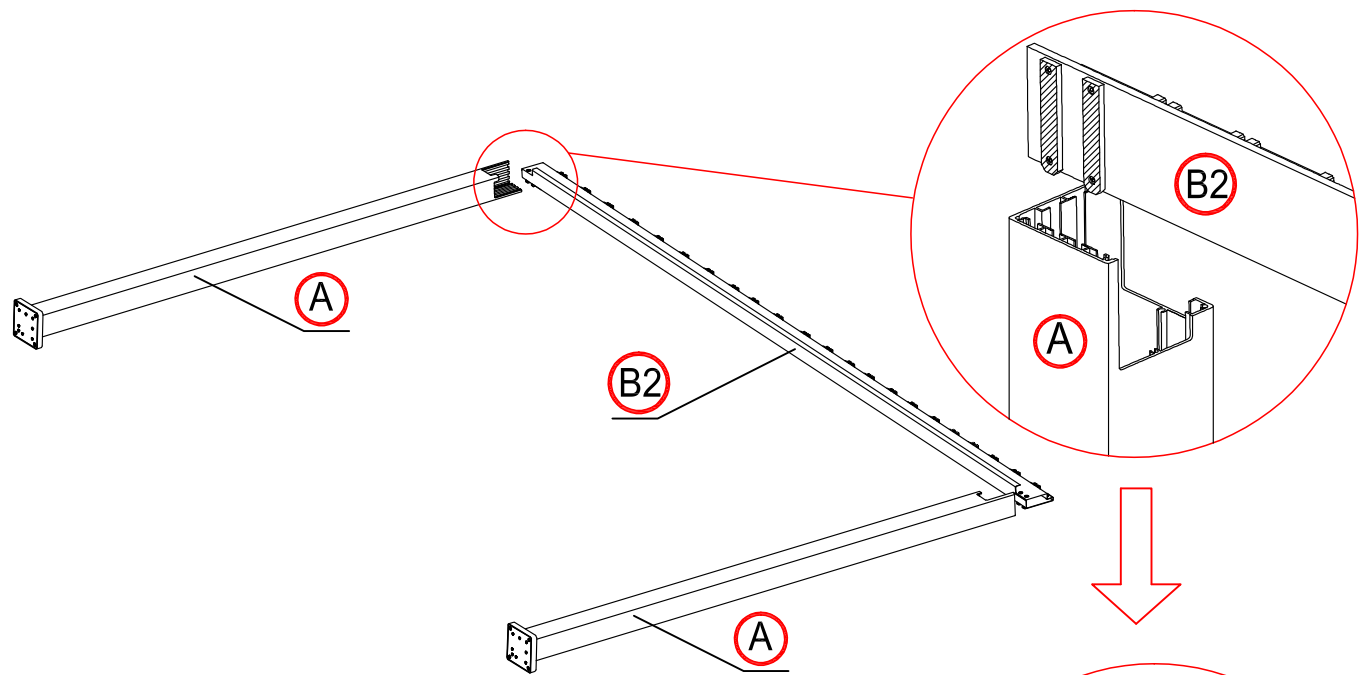

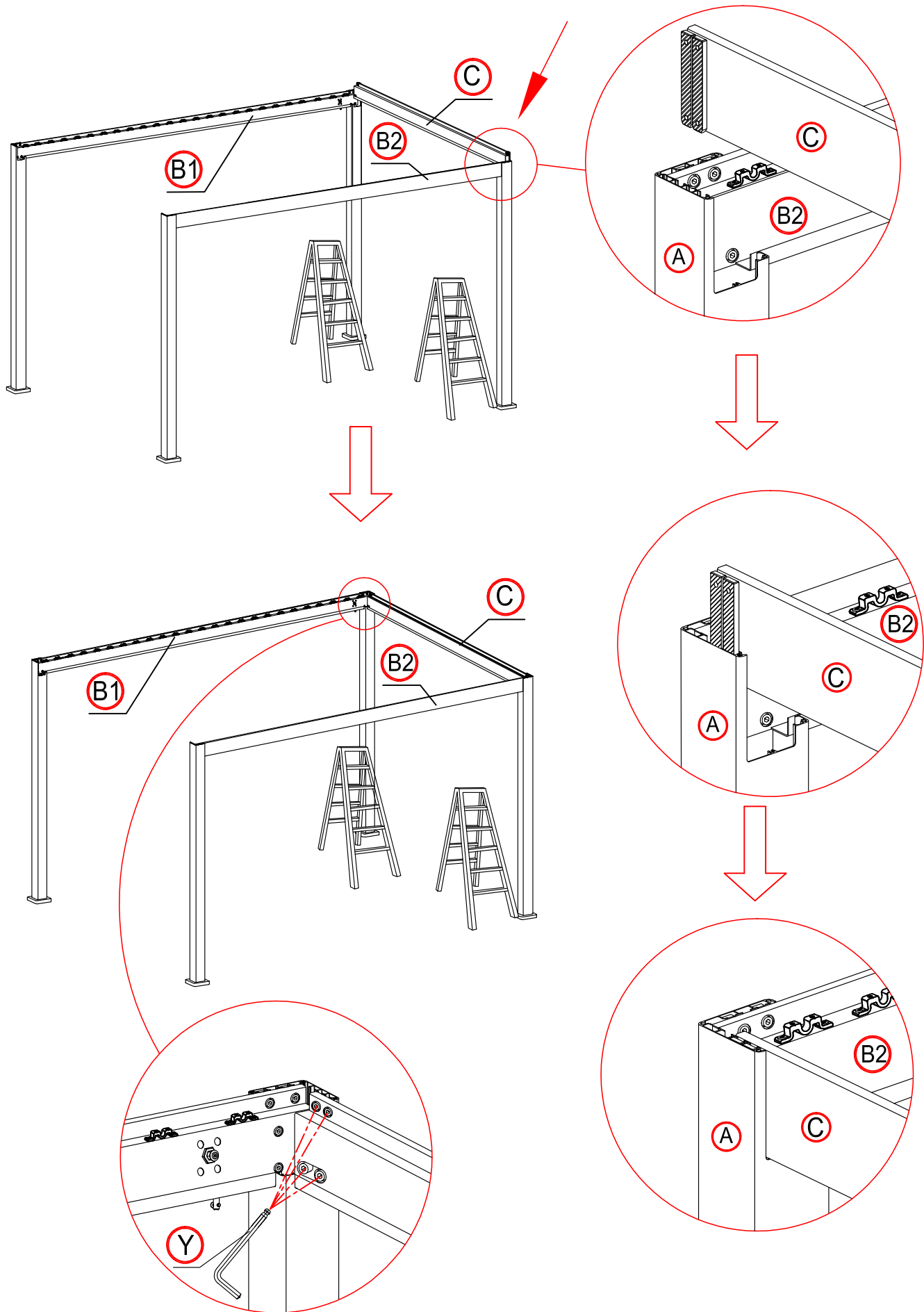

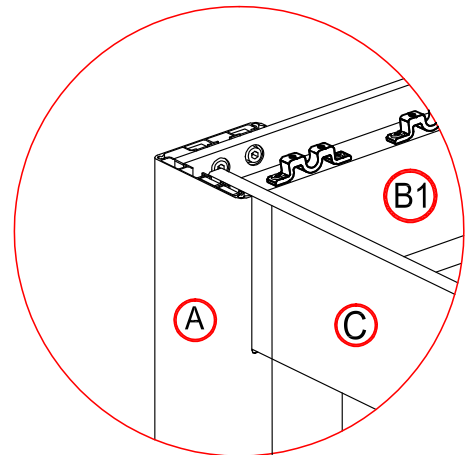
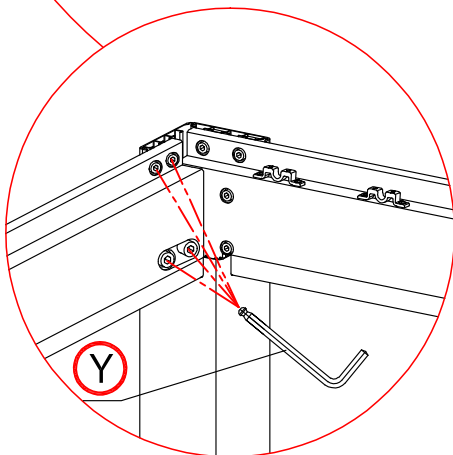
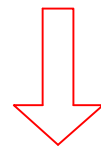
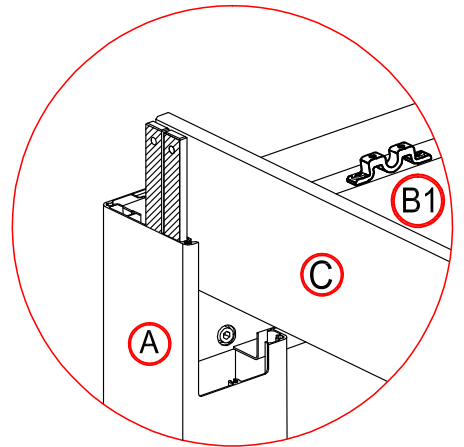
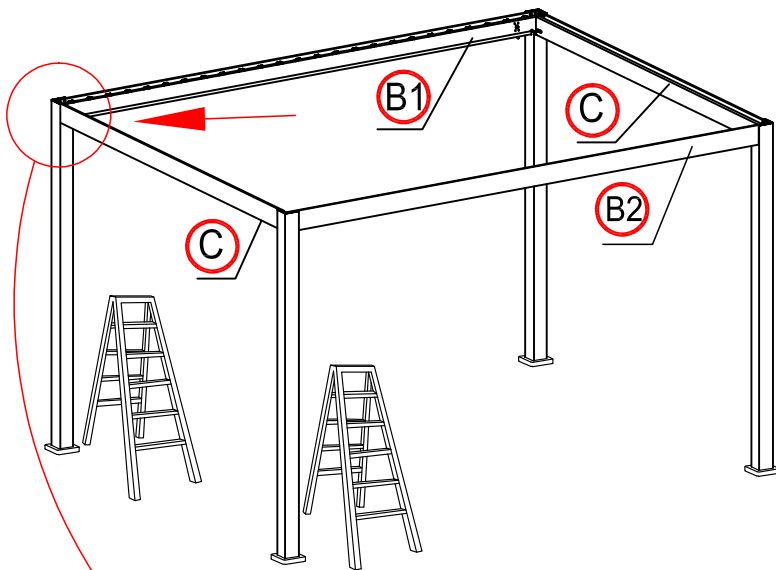
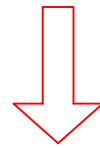
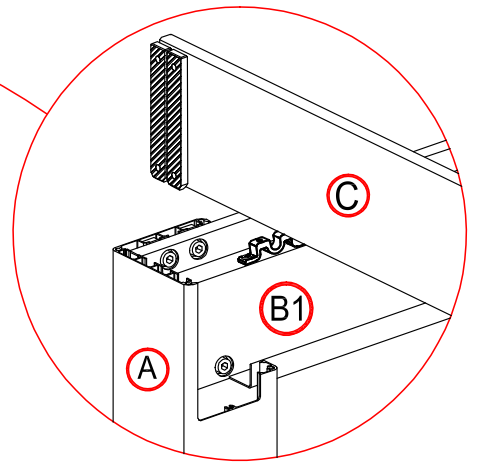
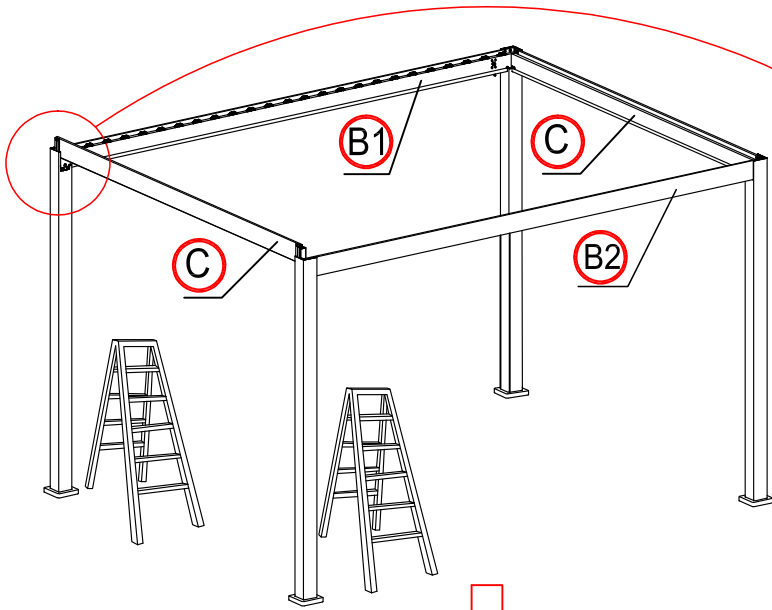

Fixer la pièce V sur son axe, puis ajouter la manivelle H.

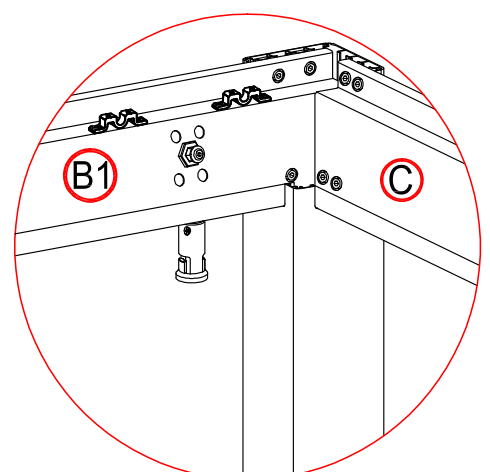
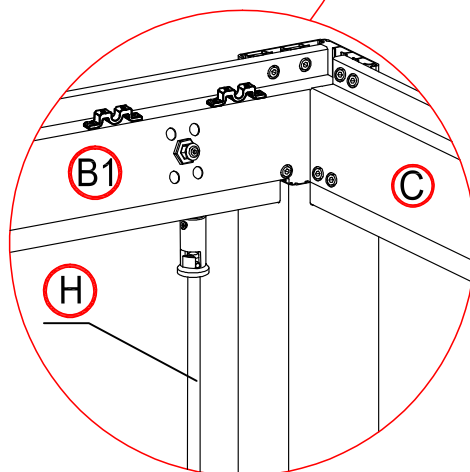
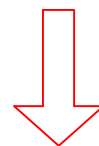
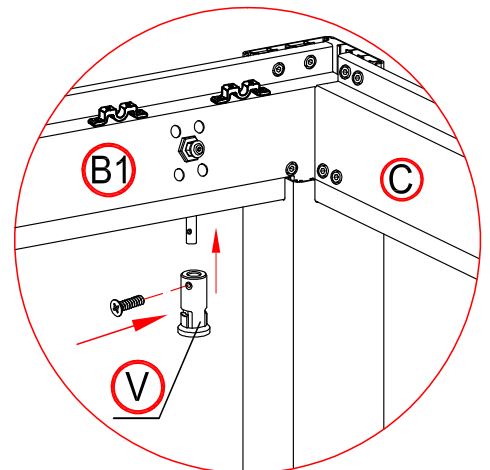
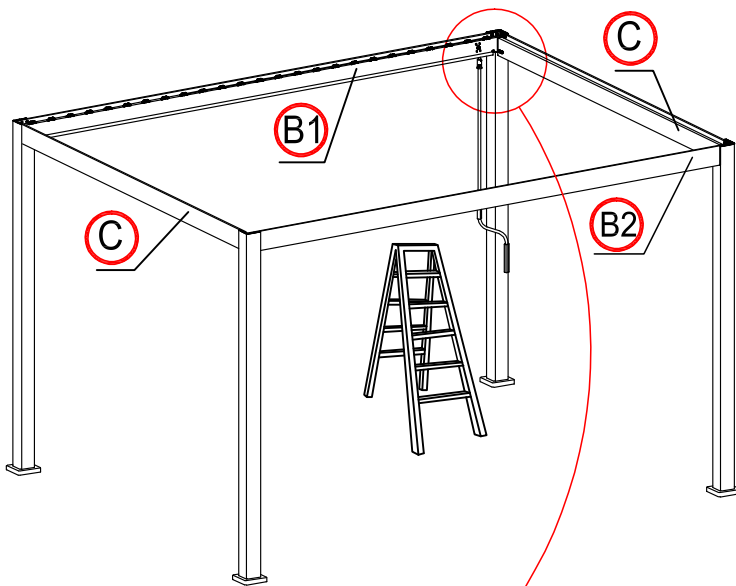
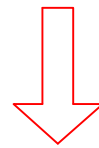
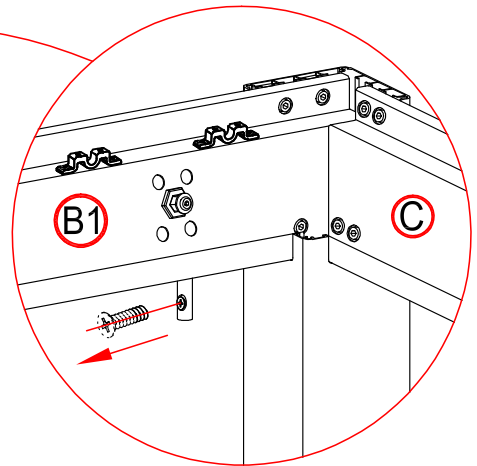
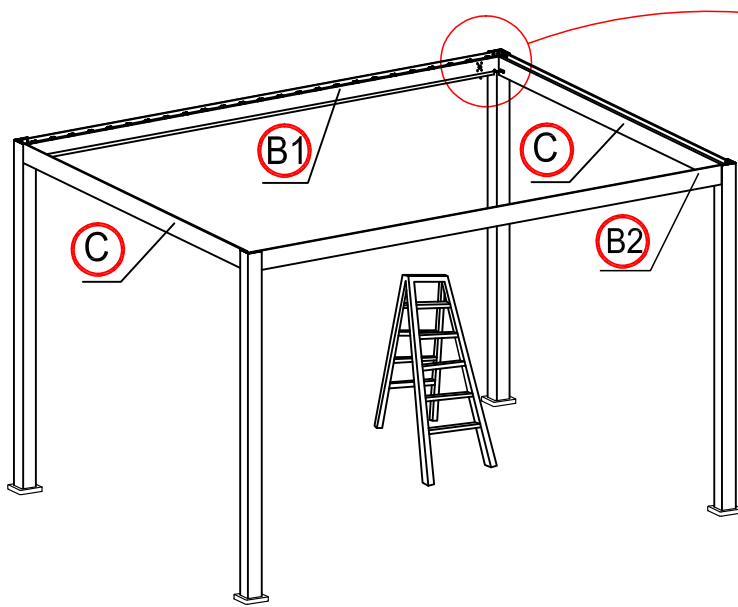

Assembler la première lame.
Visser la pièce L d'un côté et une pièce K de l'autre côté.

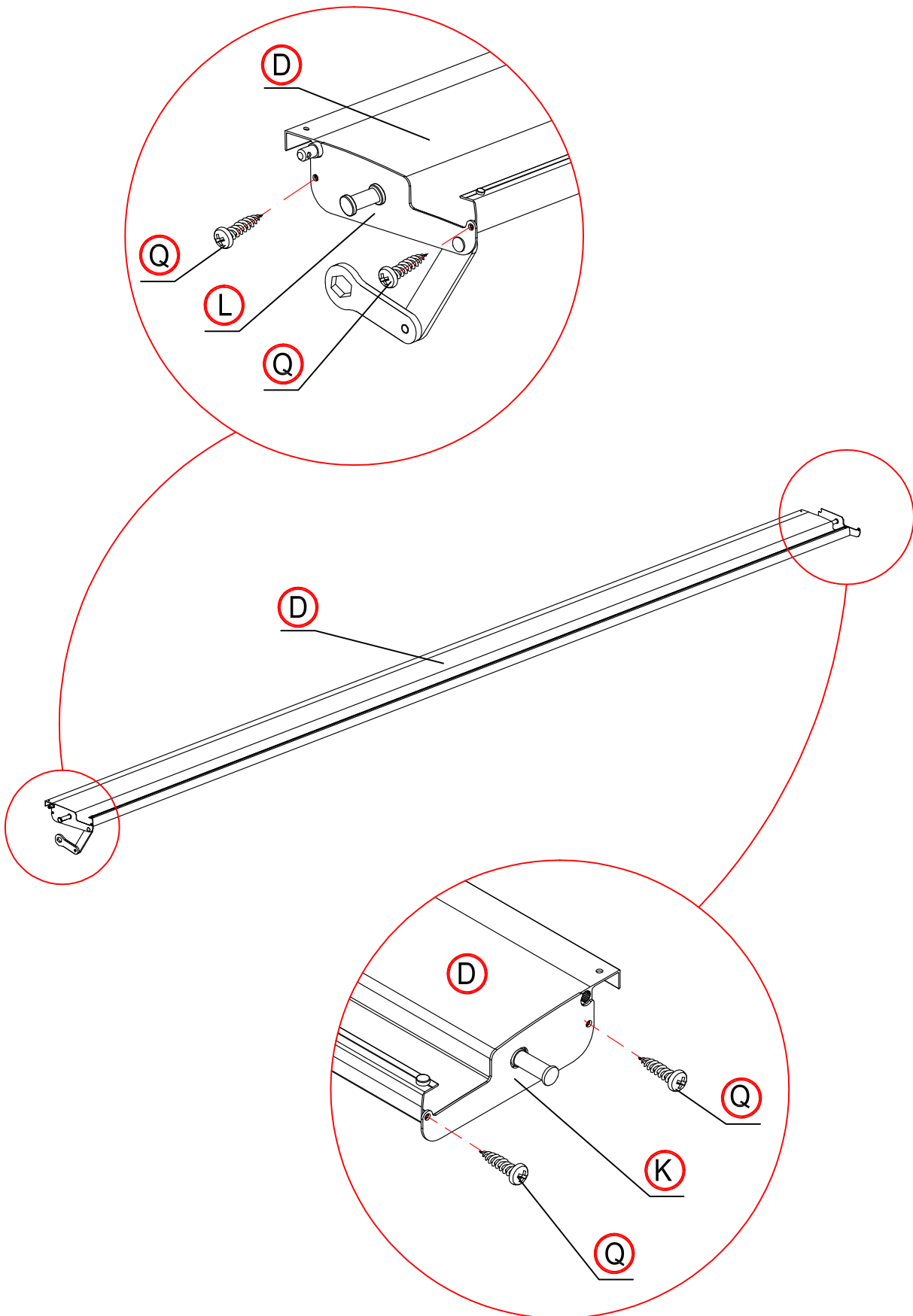

Fixer la première lame à la pergola sur la seconde position en commençant du côté manivelle.

Insérer le bras dans son logement, la lame en position verticale, le bras doit être replié et rentrer complètement dans le trou prévu à cet effet.

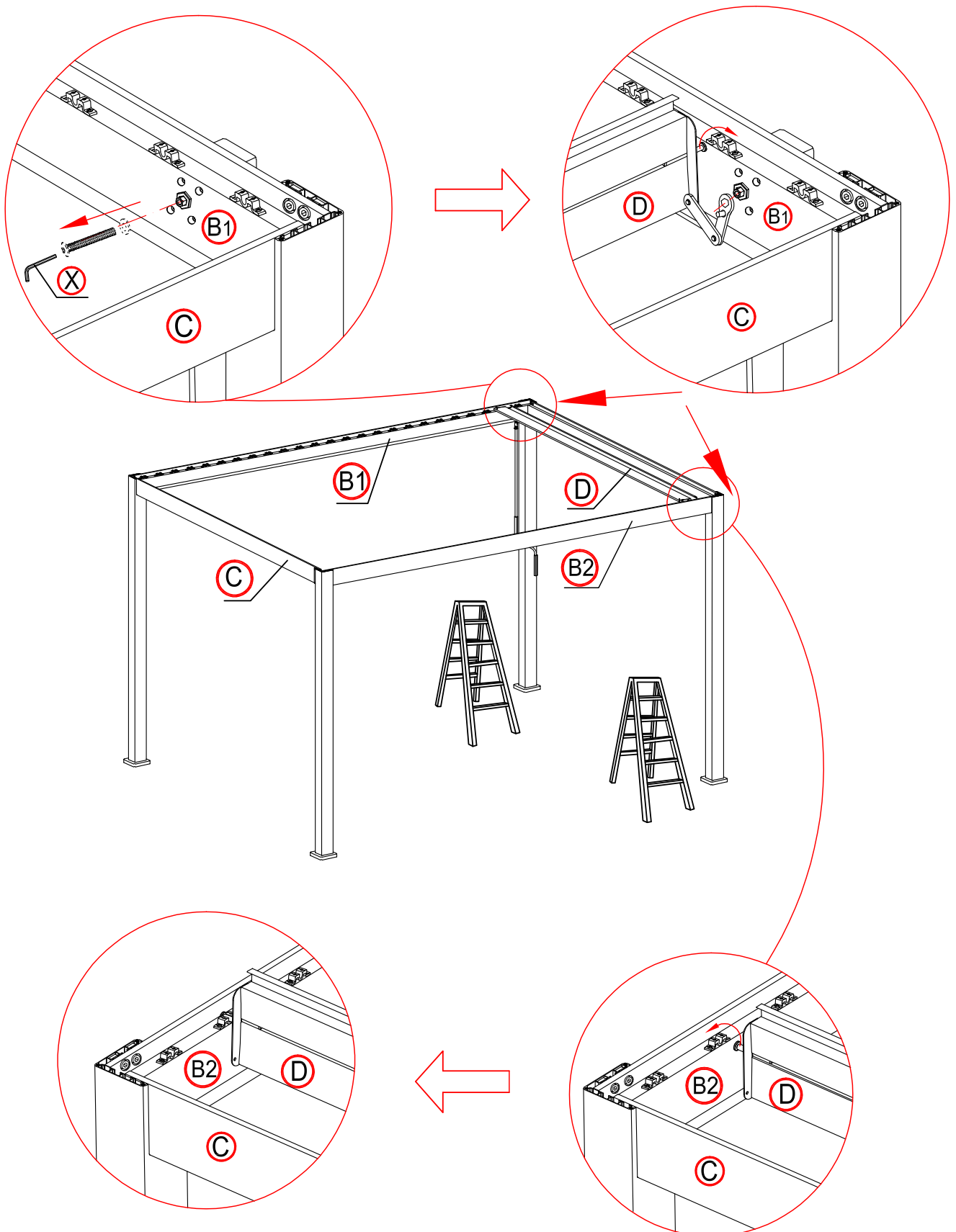

Fixer le bras à l'aide de la vis et de l'écrou qui ont été retirés à l'étape précédente.

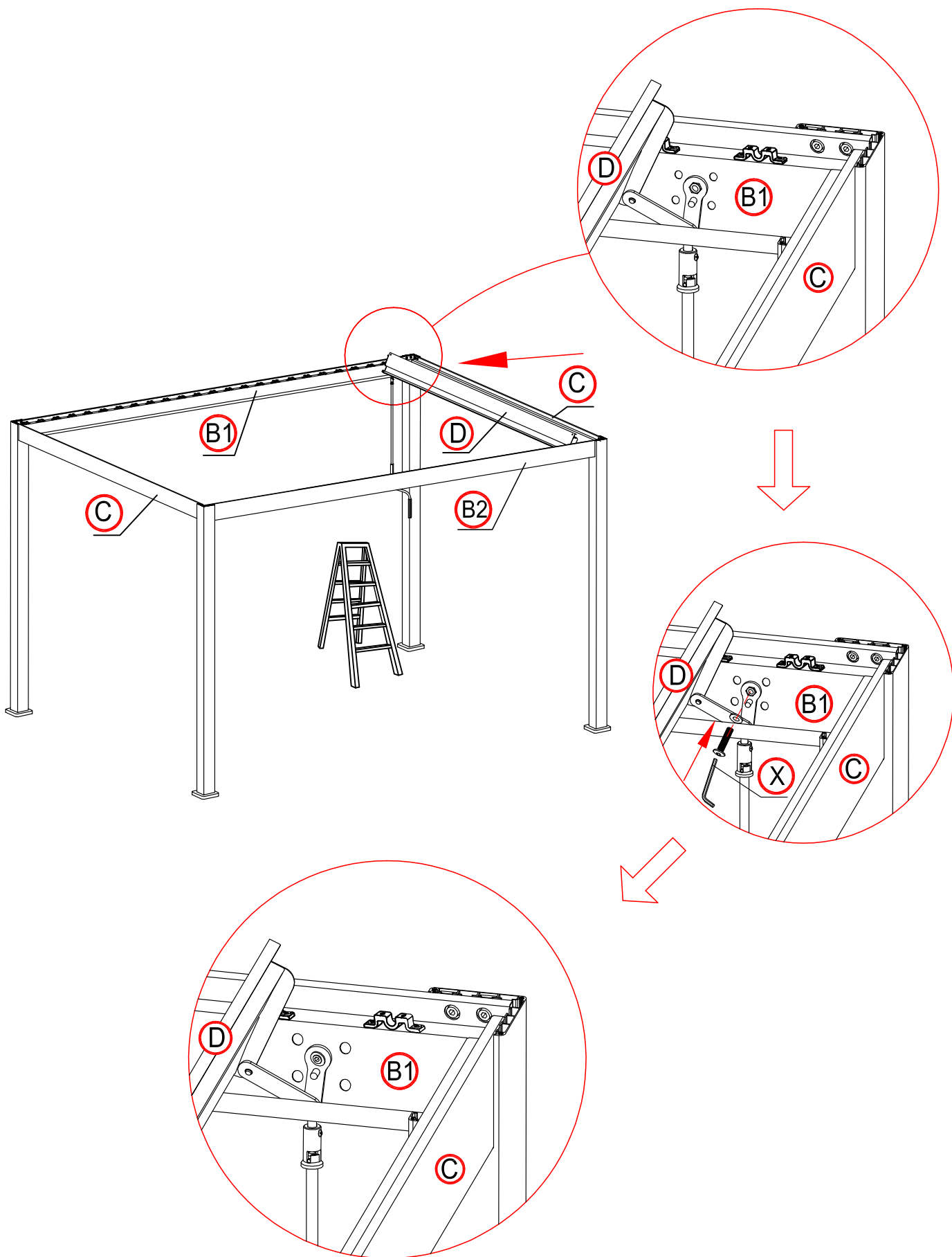

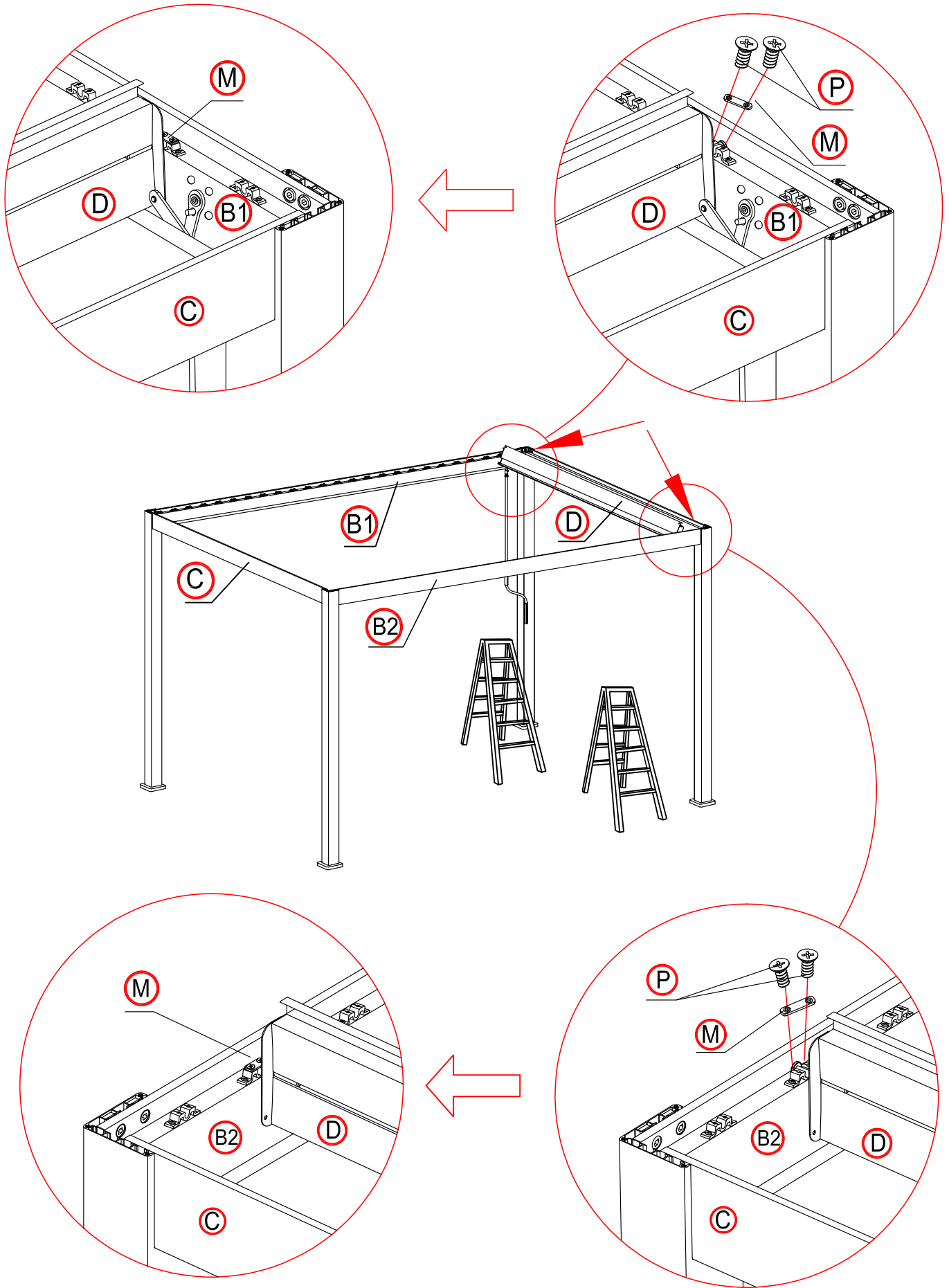

S'assurer du bon fonctionnement de la lame en la positionnant à la verticale et à l'horizontale à l'aide de la manivelle H.

Assembler les 24 autres lames sur une surface plate et propre afin de ne pas abîmer la peinture.
Commencer par visser légèrement puis resserrer une fois que toutes les vis sont positionnées.

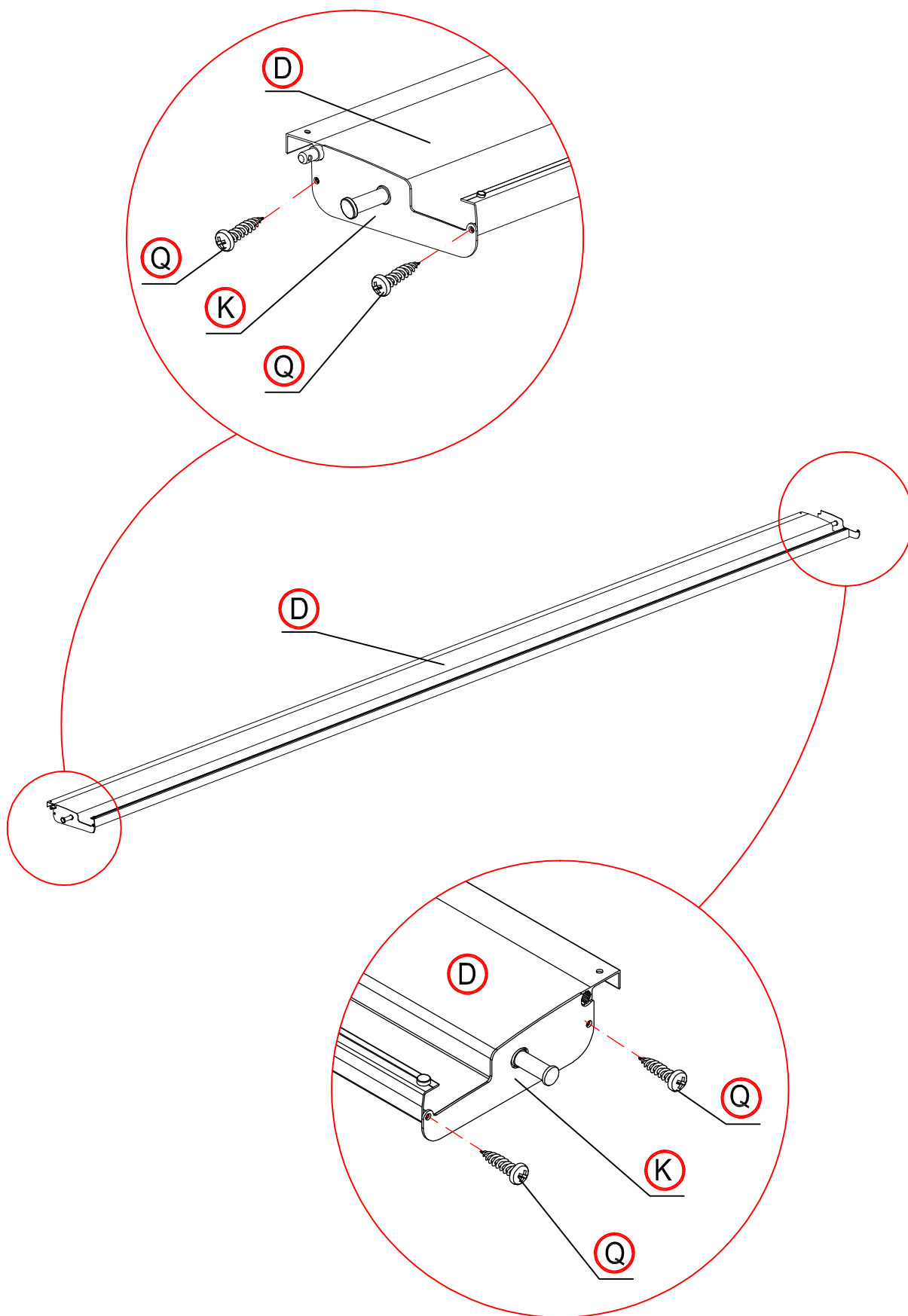

Fixer la seconde lame à la première position puis la positionner manuellement à l'horizontale. Positionner également la deuxième lame à l'horizontale à l'aide de la manivelle H. Vérifier la bonne étanchéité entre les 2 lames. Elles doivent naturellement s'emboîter.

Si tout est conforme, fixer l'ensemble des lames.

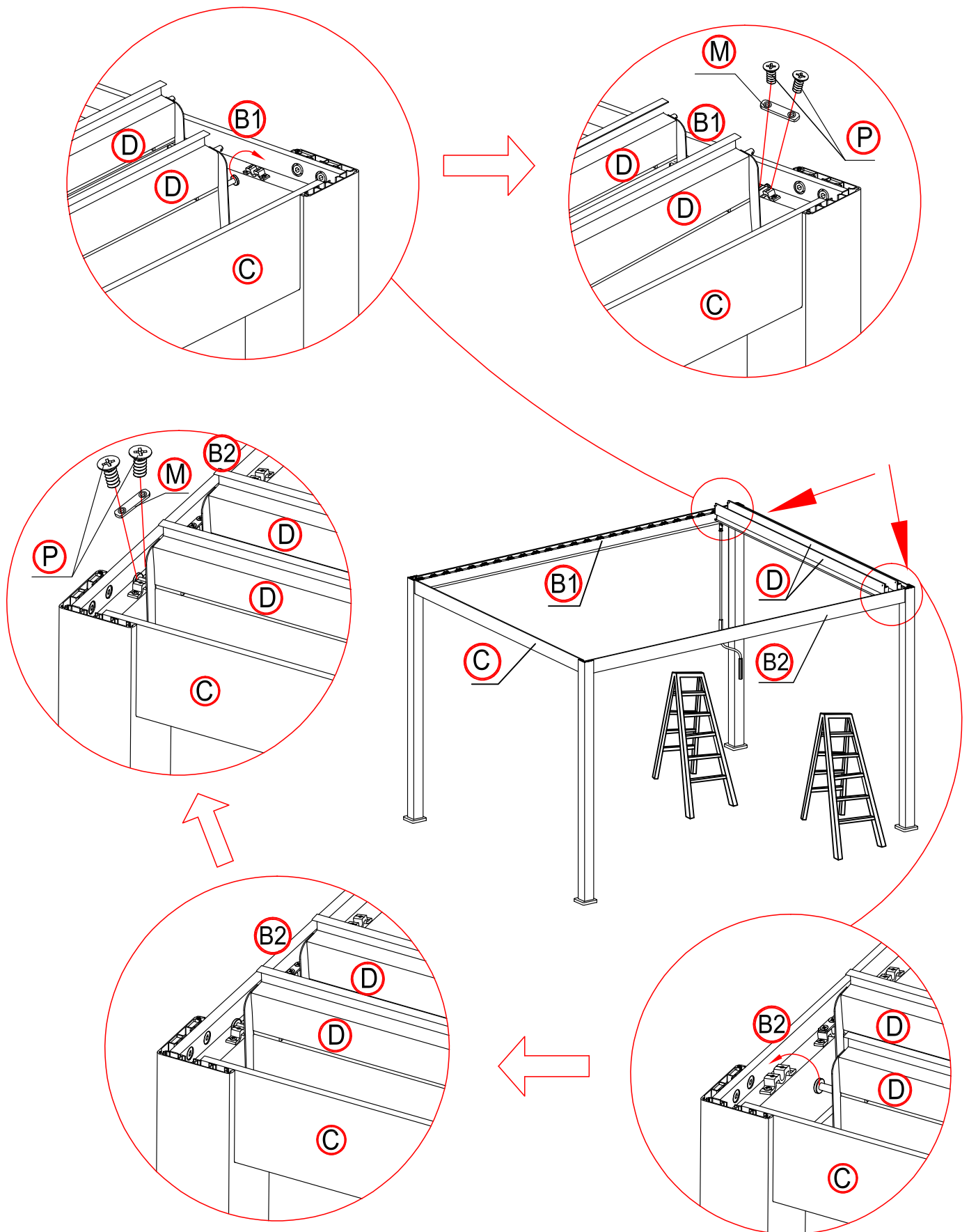

Installation des lames

Etape 1 : Positionner la 2e lame à la verticale à l'aide de la manivelle H.

Etape 2 : Prendre la pièce G et les goupilles S.

Etape 3 : Positionner la 1ère lame à la verticale et emboîter la pièce G (voir schéma page suivante) – insérer les goupilles S pour maintenir les lames.

2 personnes sont nécessaires.

Répéter cette opération pour fixer toutes les lames à la pièce G.

Etape 4 : S'assurer du bon fonctionnement du mécanisme une fois l'installation terminée.

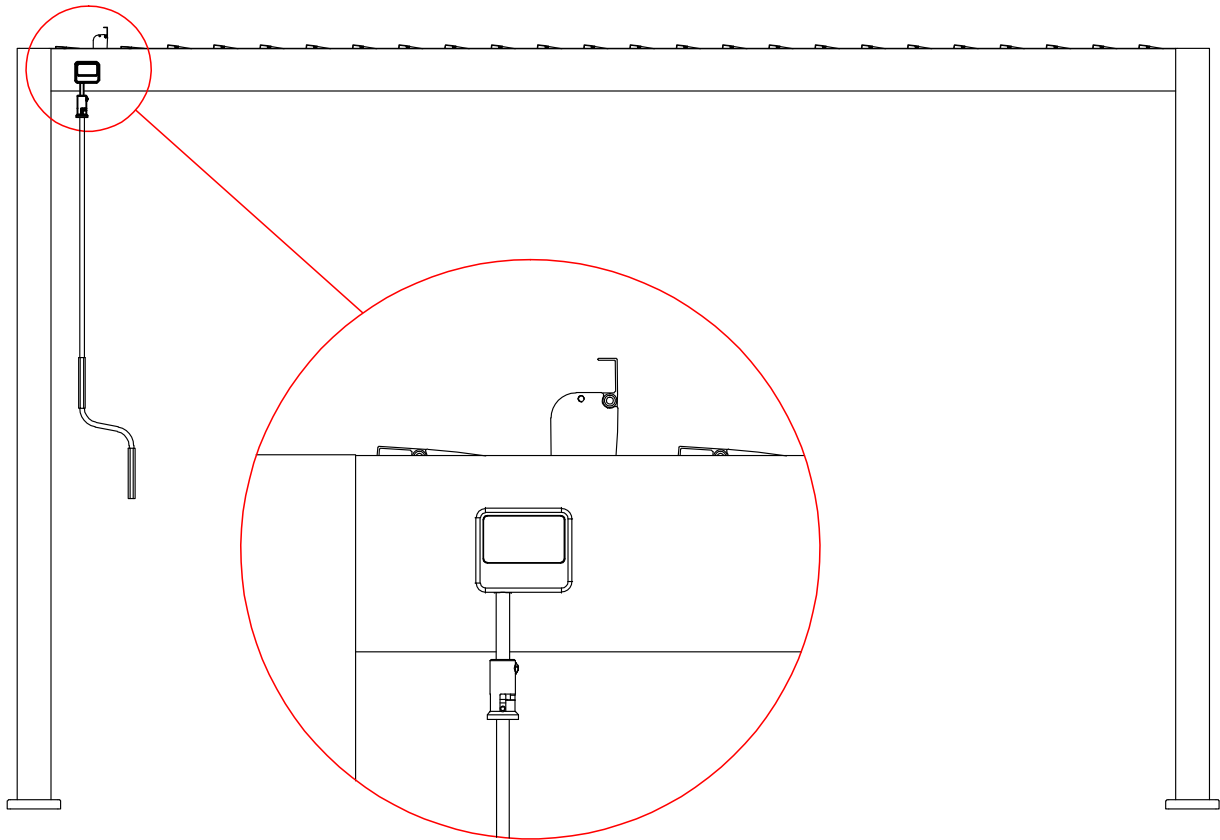

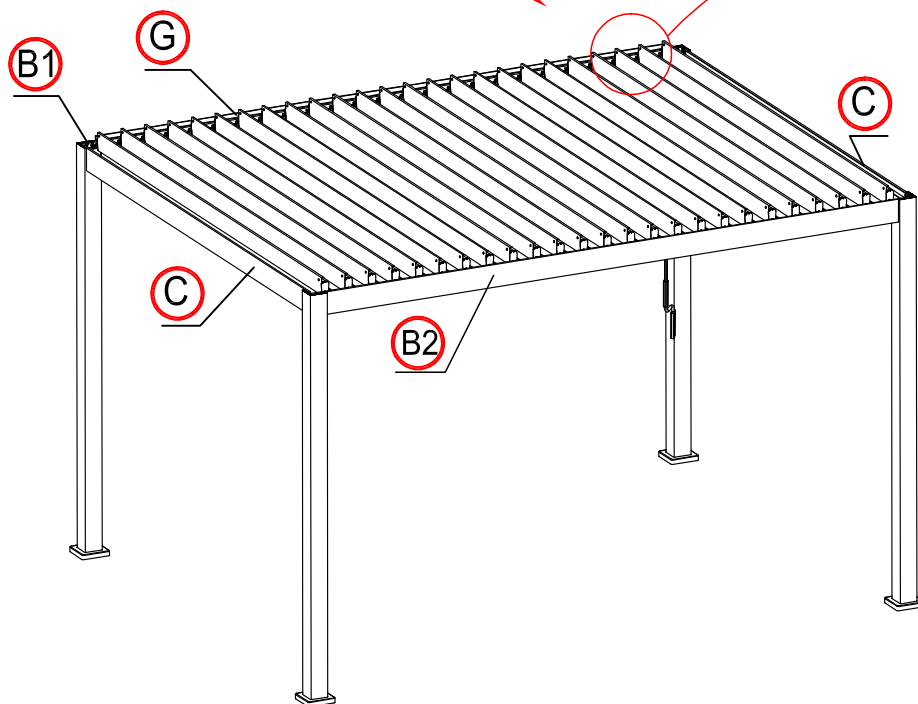
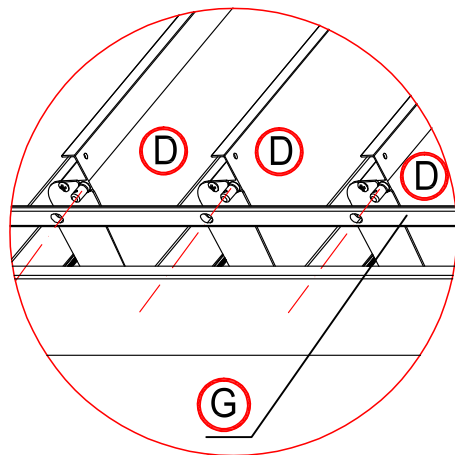
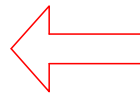
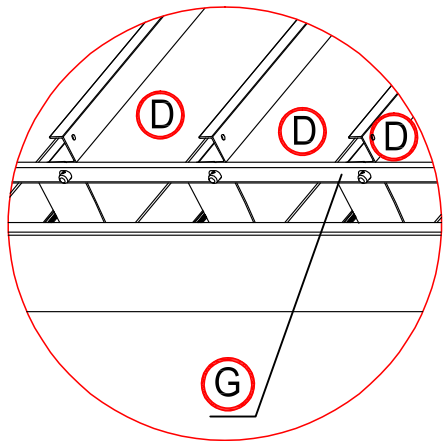
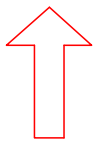
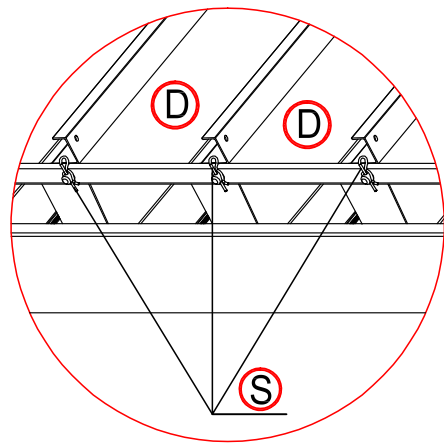
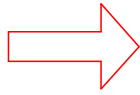
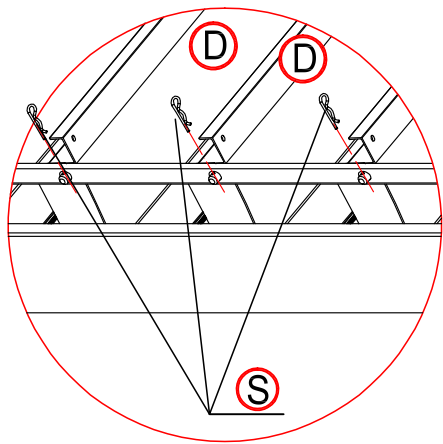

Fixer la pièce N sur chaque angle de la pergola.

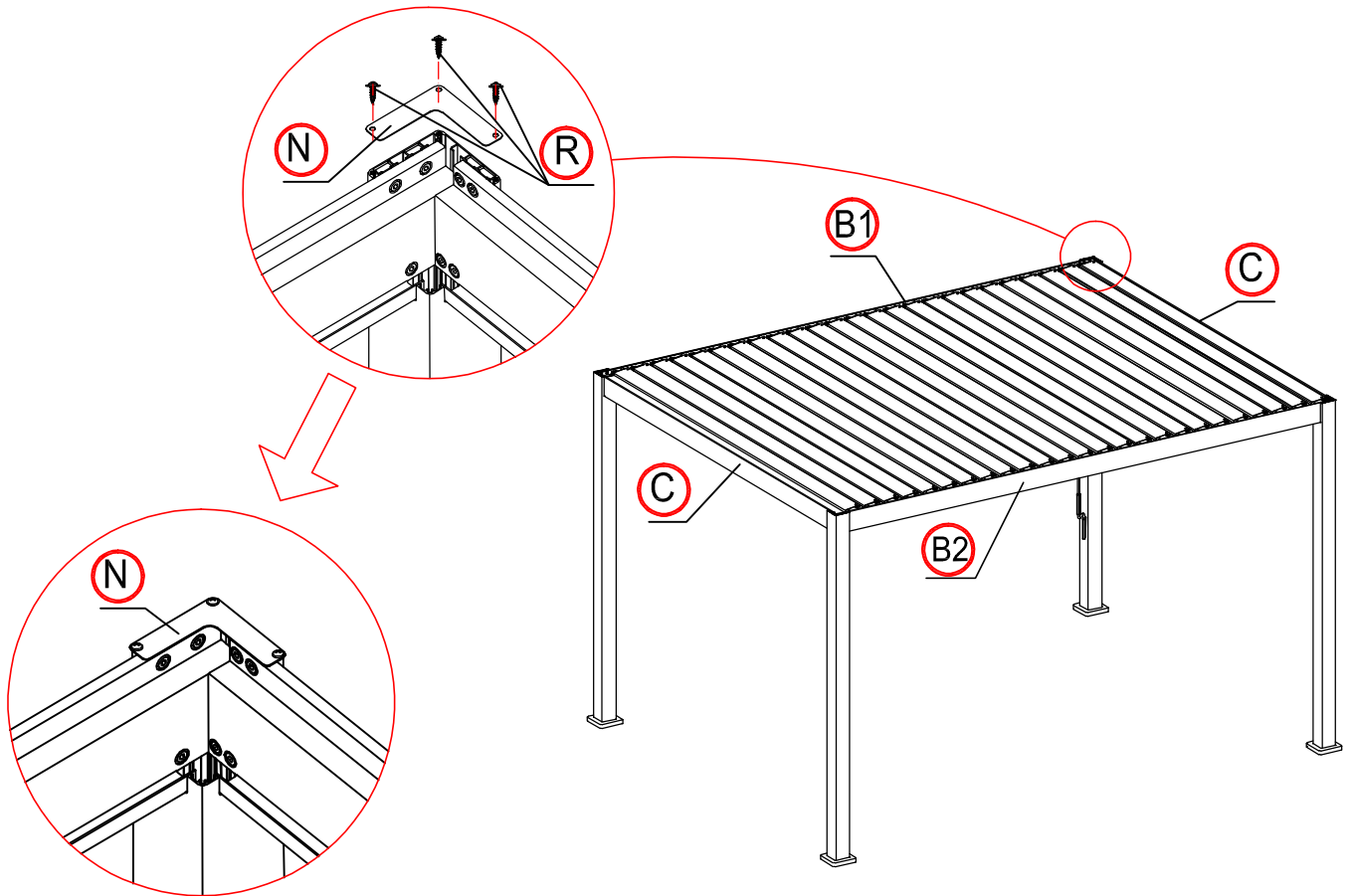

Fixer les pieds de la pergola au sol à l'aide des pièces W sur une fondation adéquate, stable et nivelée, de préférence en béton.

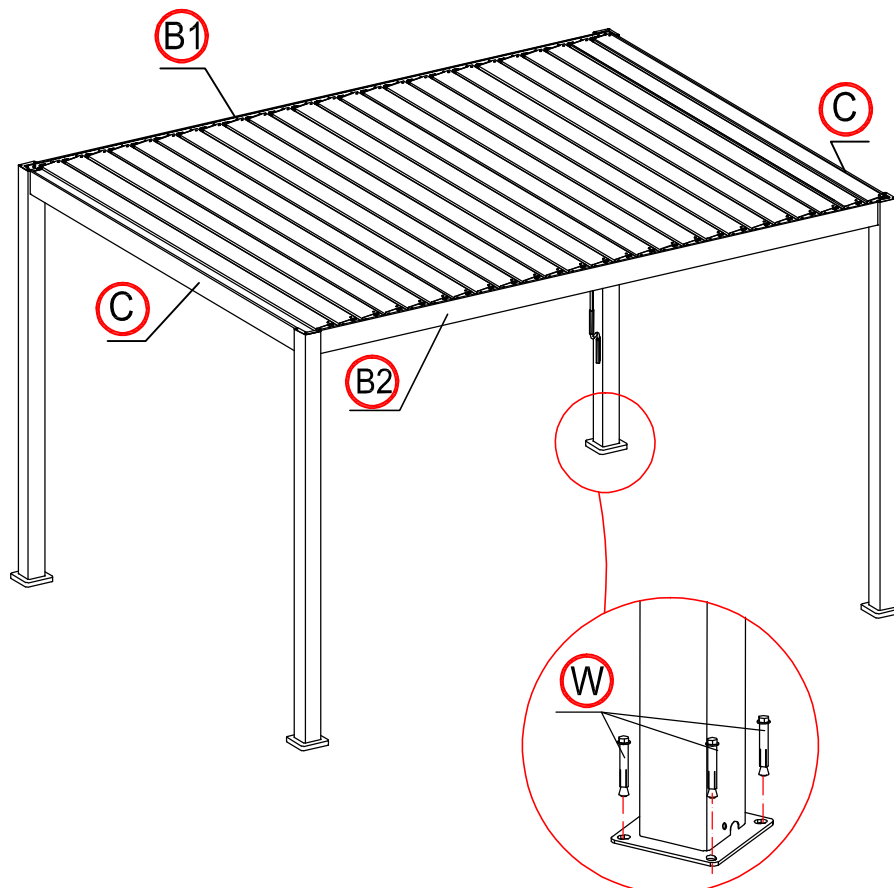

9. QUESTIONS TECHNIQUES

Pour toute question technique sur nos pergolas bioclimatiques, n'hésitez pas à vous rapprocher de votre revendeur ou consulter notre page FAQ sur notre site internet : www.pergola-ombrea.com/fr

Nous mettons également à disposition nos notices et des vidéos de montage à l'adresse www.pergola-ombrea.com/fr/notices

10. ACCESSOIRES

CÔTÉ DE 4 MÈTRES

STORE LATÉRAL OMBRÉA®

CÔTÉ DE 3 MÈTRES

4M

Antracite : 15-709300

Blanc : 15-709317

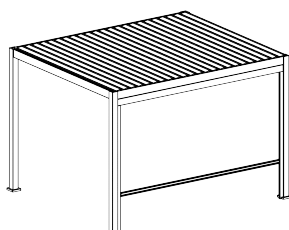

3M

Antracite: 15-709263

Blanc: 15-709270

PANNEAU LATÉRAL À VENTELLES OMBRÉA®

1,3M

Antracite : 15-711532

Blanc : 15-711549



1M

Antracite : 15-710399

Blanc : 15-710405

11. SATISFACTION

Dans le but de toujours nous améliorer, n'hésitez pas à nous faire part de vos remarques / suggestions à l'adresse suivante : contact@pergola-ombrea.com

Nous serions ravis de recevoir des photos de votre installation.

Nous vous remercions pour votre achat et nous vous souhaitons des jours heureux sous votre pergola.

Pérgola Bioclimática Autoportante 3x4M

Le aconsejamos conservar estas instrucciones para consultas futuras. Le rogamos leer atentamente estas instrucciones antes de empezar el montaje. El cliente será responsable de cualquier daño o lesión ocasionada por un uso inadecuado del producto.

1. PRECAUCIONES DE SEGURIDAD

Este producto no debe usarse en condiciones climáticas severas: tormenta, viento fuerte, granizo, nieve. Garantizamos la resistencia de la pérgola para soportar vientos hasta 110 km/h y un peso máximo de nieve de 55 kg / m².

En caso de viento o nieve violento, se recomienda dejar las lamas en posición abierta. Si se olvida, habrá que quitar la nieve de la pérgola para evitar una sobrecarga significativa en las lamas.

Nuestra pérgola puede soportar lluvias fuertes, no obstante, no podemos asegurar una impermeabilidad al 100%. En caso de fenómenos meteorológicos excepcionales, su estanqueidad puede verse comprometida. No guarde enseres que temen la humedad debajo de la pérgola.

No se sube al tejado ni a la estructura de la pérgola.

2. MONTAJE

Dependiendo de la ubicación y la superficie, las construcciones pueden estar sujetas a una solicitud de permiso de obra. Ponerse en contacto con las autoridades locales para determinar si la instalación está autorizada.

Montaje del producto :

- Se necesitan de 2 a 3 personas.
- Mantenga a los niños lejos de la zona de montaje.
- Tenga cuidado con el riesgo de pellizcos. Llevar siempre guantes de protección.
- Nunca apriete completamente los tornillos antes de haber ensamblado la pieza en cuestión.
- Es importante seguir estas instrucciones paso a paso.

No se pueden realizar modificaciones en el producto. Los productos modificados por el cliente no están cubiertos por la garantía del fabricante.

La ubicación debe elegirse de forma adecuada. Se recomienda evitar montar su pérgola de cara a los vientos dominantes y debajo de un árbol.

La pérgola debe montarse sobre una superficie estable y nivelada, se recomienda instalarla sobre una losa de hormigón o soportes de hormigón al nivel de cada poste. Le pedimos que ancle correctamente la pérgola al suelo utilizando las piezas W.

Si desea colocar su pérgola cerca de su casa o edificio, le pedimos que verifique la presencia de canales de desagüe. La pérgola no podrá resistir y garantizar una estanqueidad perfecta si el agua de lluvia de su hogar fluye hacia ella.

En caso de incumplimiento de las recomendaciones de montaje, no se podrá aplicar la garantía.

3. MANTENIMIENTO

Es necesario un mantenimiento regular para asegurar la longevidad y conservar el aspecto estética inicial del producto.

Recomendamos:

- Lave su pérgola una o dos veces al año con agua, una esponja o un trapo suave. No usar productos agresivos ni soportes abrasivos.
- Compruebe la presión de los tornillos con regularidad (al menos una vez al año).
- Engrase las piezas de tornillerías con regularidad (al menos una vez al año).
- Asegúrese de que nada interfiera con el flujo de agua en las canales de desagüe (hojas, ramas...).
- Elimine el agua que pueda estancarse alrededor de los pies de la pérgola (llevando la protección).

4. GARANTÍA

Ombrea® garantiza la disponibilidad de las piezas de repuestos durante 2 ó 5 años (según el producto). La garantía solo se aplicará si el almacenamiento, montaje, uso de forma normal y mantenimiento regular se respetan.

- Exclusión de la garantía:
- El desgaste normal inherente a los productos.
- Pérdida o rotura de cualquier pieza durante el desembalaje o la instalación.
- Falta de mantenimiento, negligencia, vandalismo, impactos con objetos extraños, uso de fuerza, contacto con abrasivos, estética, desmantelamiento, reconstrucción o reubicación.
- Fuerzas mayores: granizo, vientos fuertes, tormentas, nieve, inundaciones, rayos ...

La garantía se limita a la sustitución de piezas de repuestos o del producto suministrado, excluyendo todo gastos y compensaciones de cualquier tipo.

Todas las reclamaciones de garantía deben realizarse en el punto de venta (tienda o sitio web) donde se adquirió el producto.

5. LISTA DE PIEZAS POR BULTOS







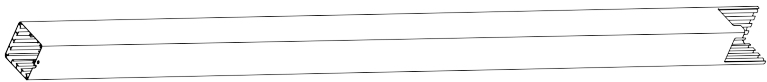

Antes de proceder al montaje de su pérgola bioclimática, revise que todas las piezas están incluidas y no dañadas.

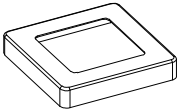
Cualquier pieza faltante debe informarse dentro de los 30 días posteriores a la compra. Puede reclamar a través de su distribuidor o enviar una solicitud directamente en nuestra página web sav.comintes.com.

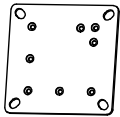
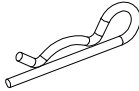
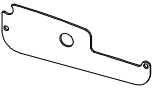
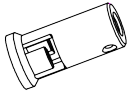
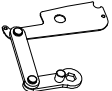
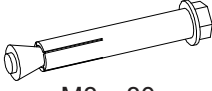
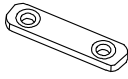

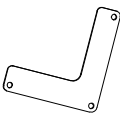
No tire el embalaje sin asegurarse de que la pérgola está funcionando correctamente.

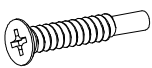
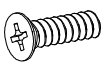
BULTOS 1/4 (COLUMNA Y TORNILLERÍA)

Referencias	Representación	Cantidad
A		4

Referencias	Representación	Cantidad	Referencias	Representación	Cantidad
I		4	R	 5.5x19mm	12
J		4	S		29
K		51	V		1
L		1	W	 M8 x 80	16
M		52	X		1
N		4	Y		2
O	 ST5.65x45	24			
P	 M5x12mm	104			
Q	 4.2x25mm	104			

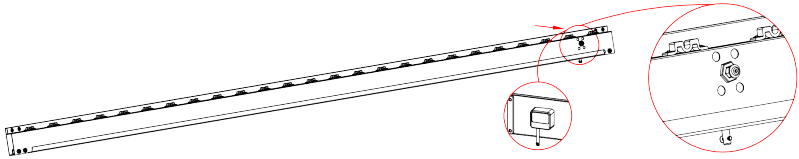
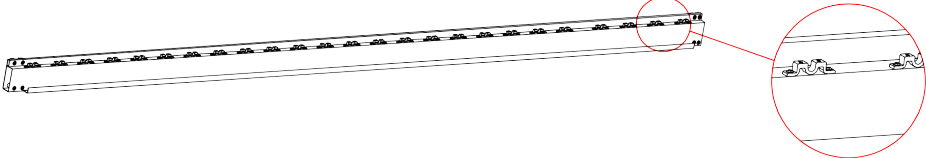
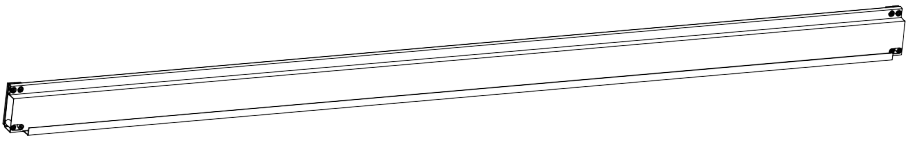
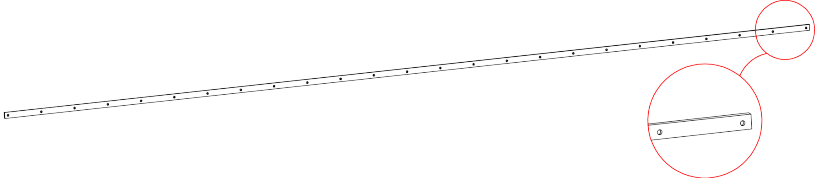
BULTOS 2/4 (CUADRO SUPERIOR)

Referencia	Representación	Cantidad
B1		1
B2		1
C		2
G		1
H		1

BULTOS 3/4 (LAMAS)

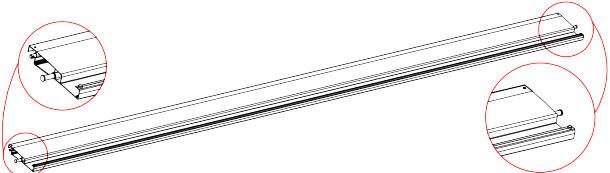
Referencia	Representación	Cantidad
D		13

BULTOS 4/4 (LAMAS)

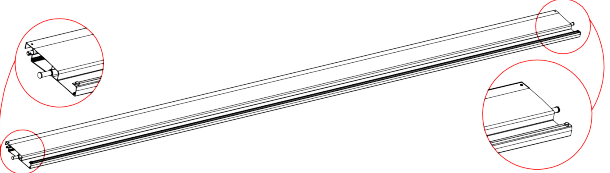
Referencia	Representación	Cantidad
D		12

6. HERRAMIENTAS NECESARIAS PARA EL MONTAJE (NO INCLUIDAS)

- Guantes
- Cúter
- Mazo
- Cascos de seguridad
- Metro
- Destornillador eléctrico
- Taladro
- Escaleras

7. PLAN DEL MONTAJE (dimensiones en mm)

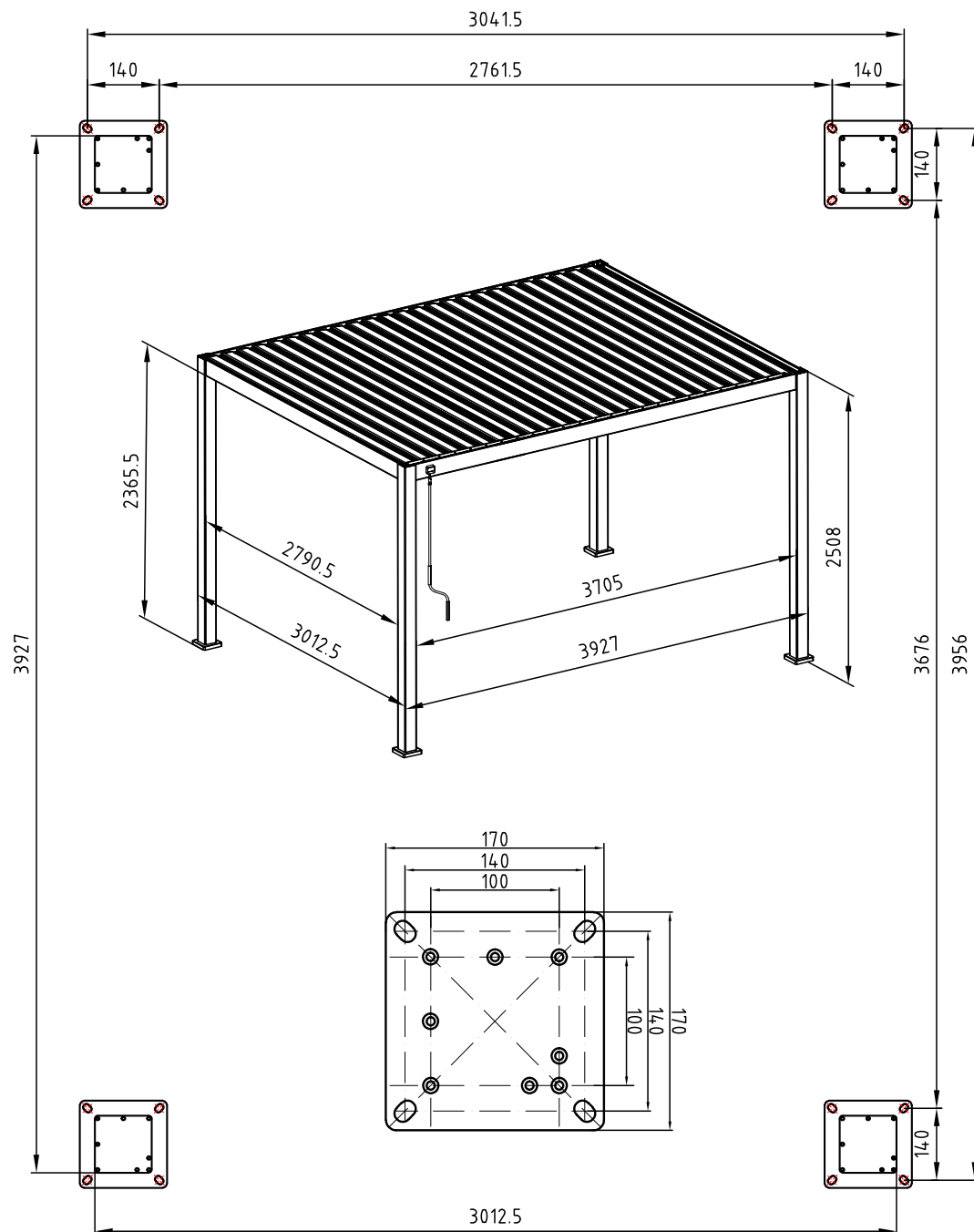

8. PASOS

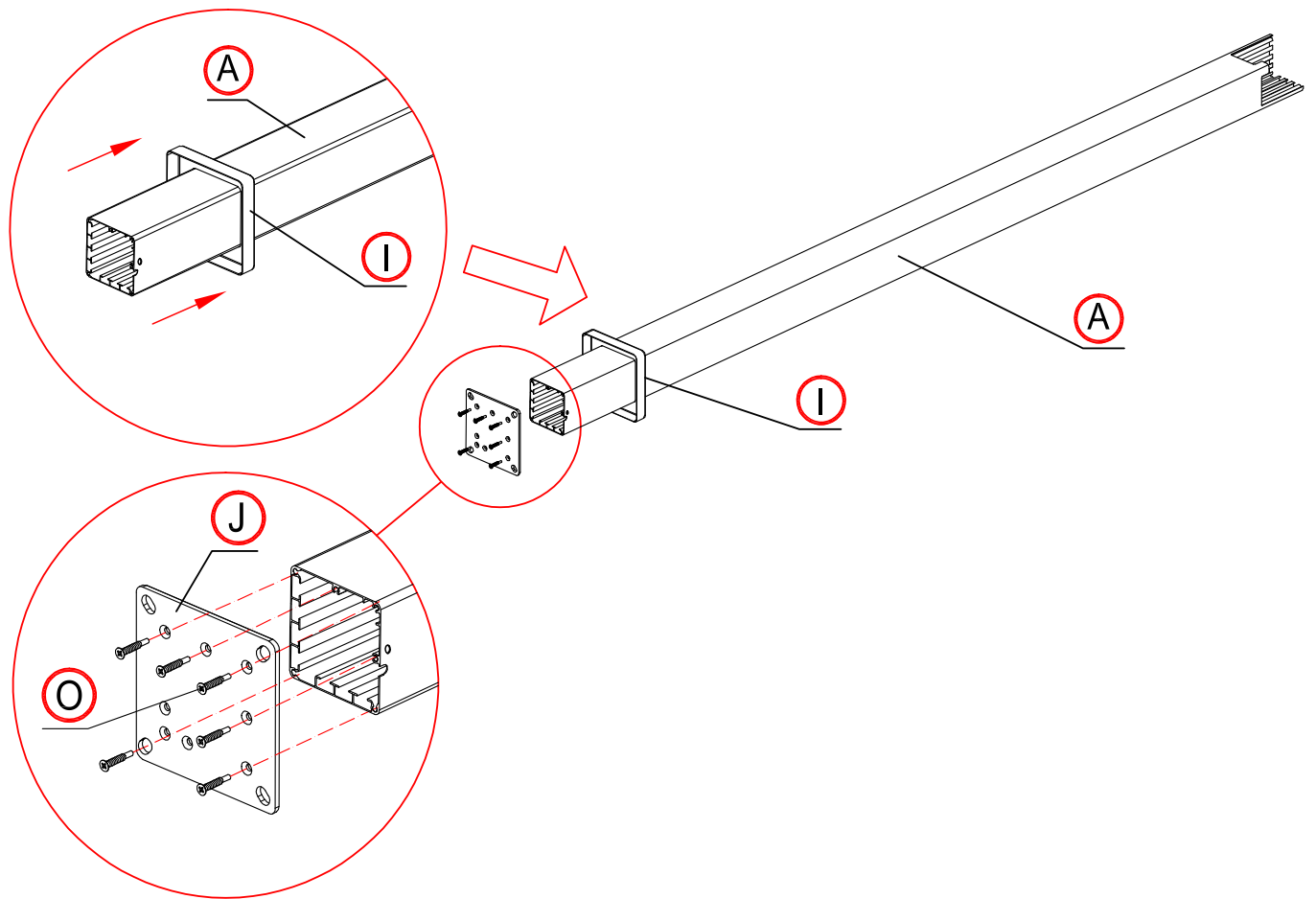

Deslice las cubiertas I en los 4 postes y luego coloque las placas J debajo de los 4 postes también.

Para no dañar la pintura, le recomendamos que las monte sobre una mesa o sobre una superficie plana y limpia.

Asegure los tornillos O con un destornillador. Empiece por apretar ligeramente y luego apretar completamente uno, después de que todos los tornillos estén en su lugar.

Afloje las placas de metal en los 2 extremos de la viga B1 (no las desenrosque completamente).

Inserte la viga B1 en las columnas A simultáneamente en ambos lados. Los platos de metal deben deslizarse en las ranuras de los postes.

Apriete las placas de metal con la herramienta Y.

Repita la misma operación para las vigas B2 y C.

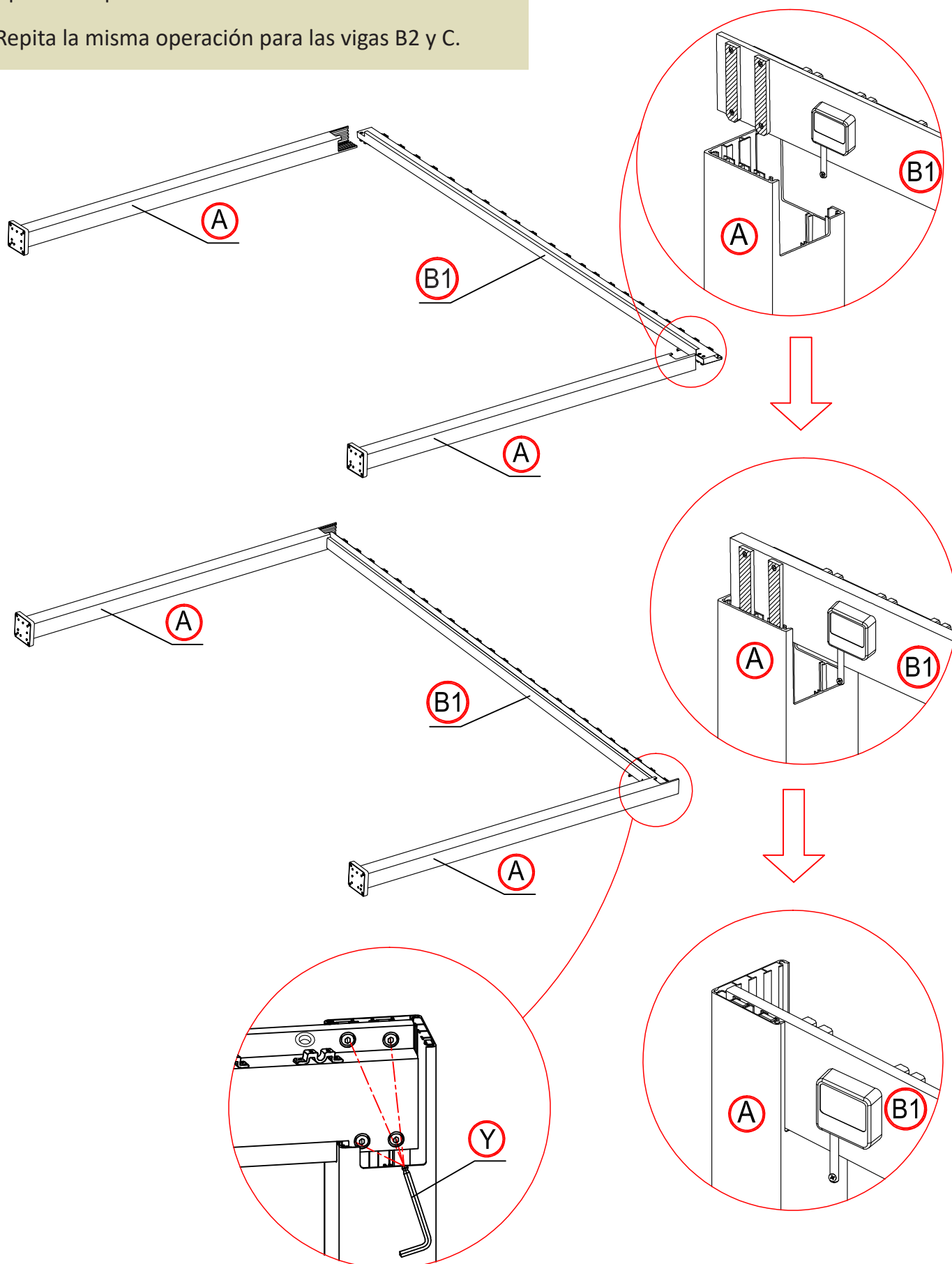

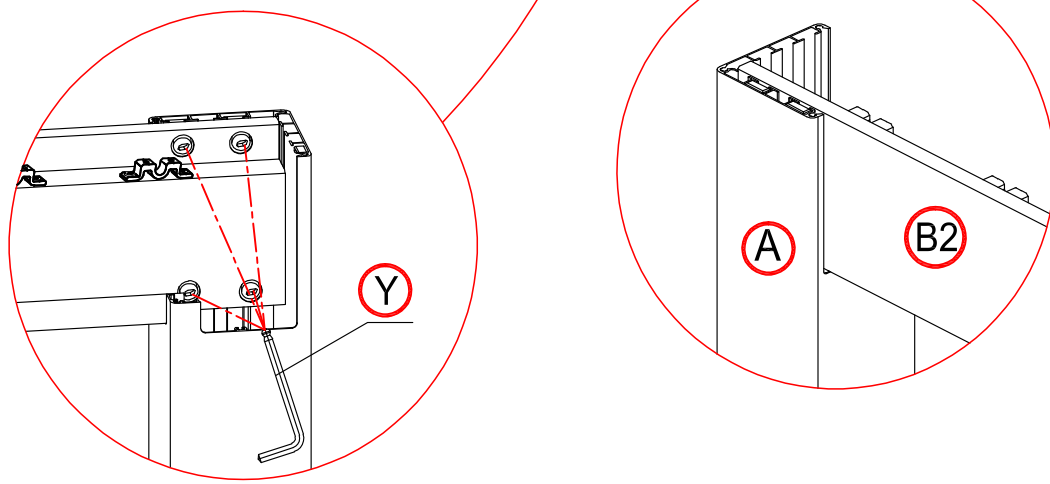
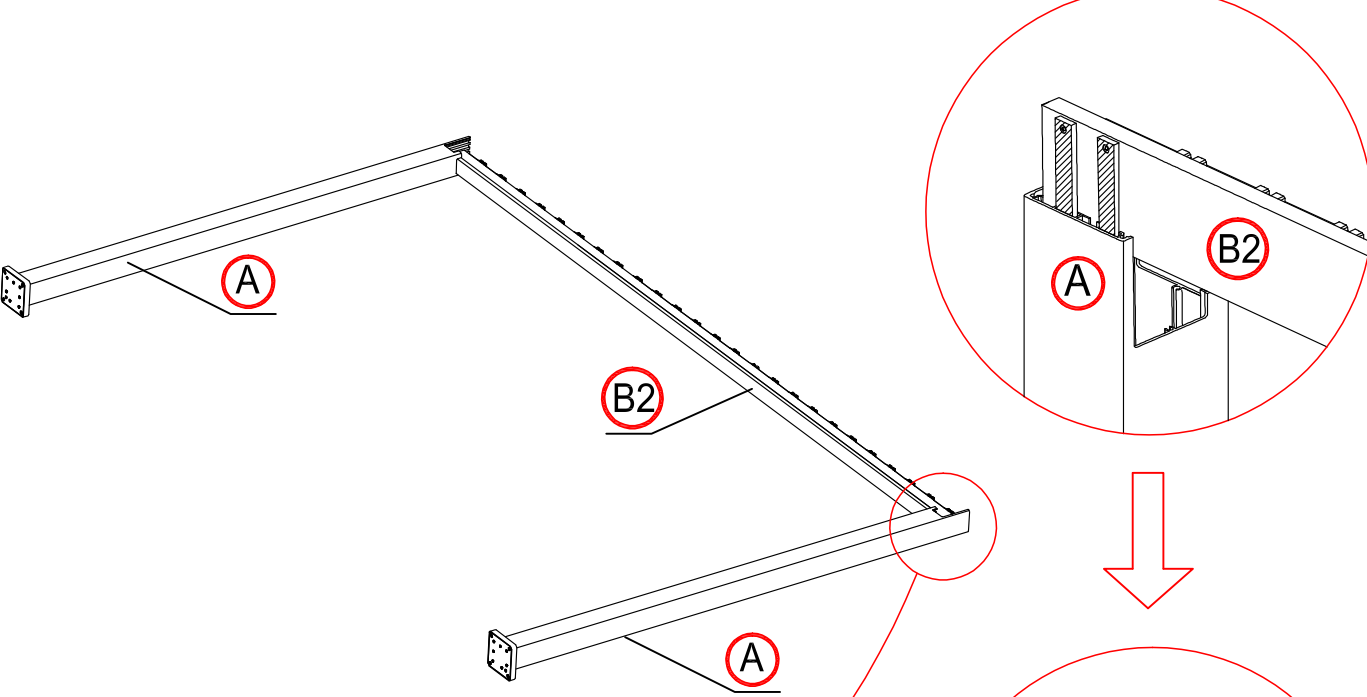
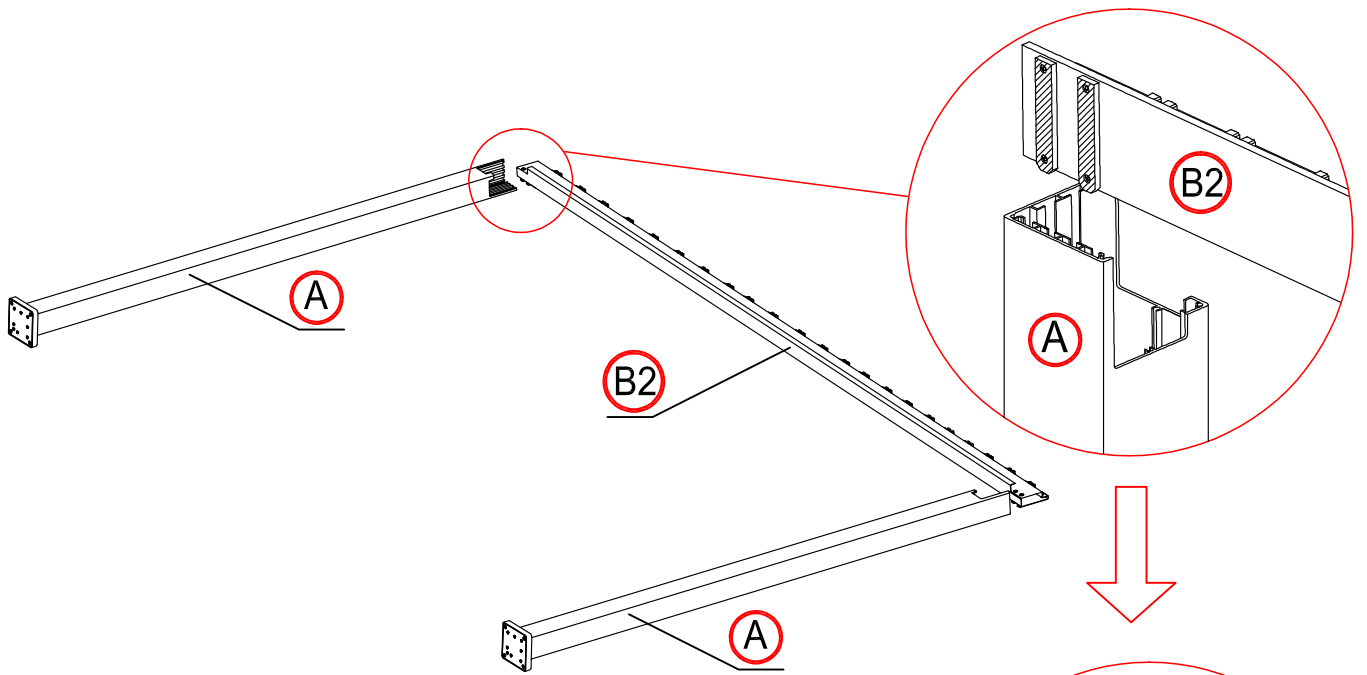

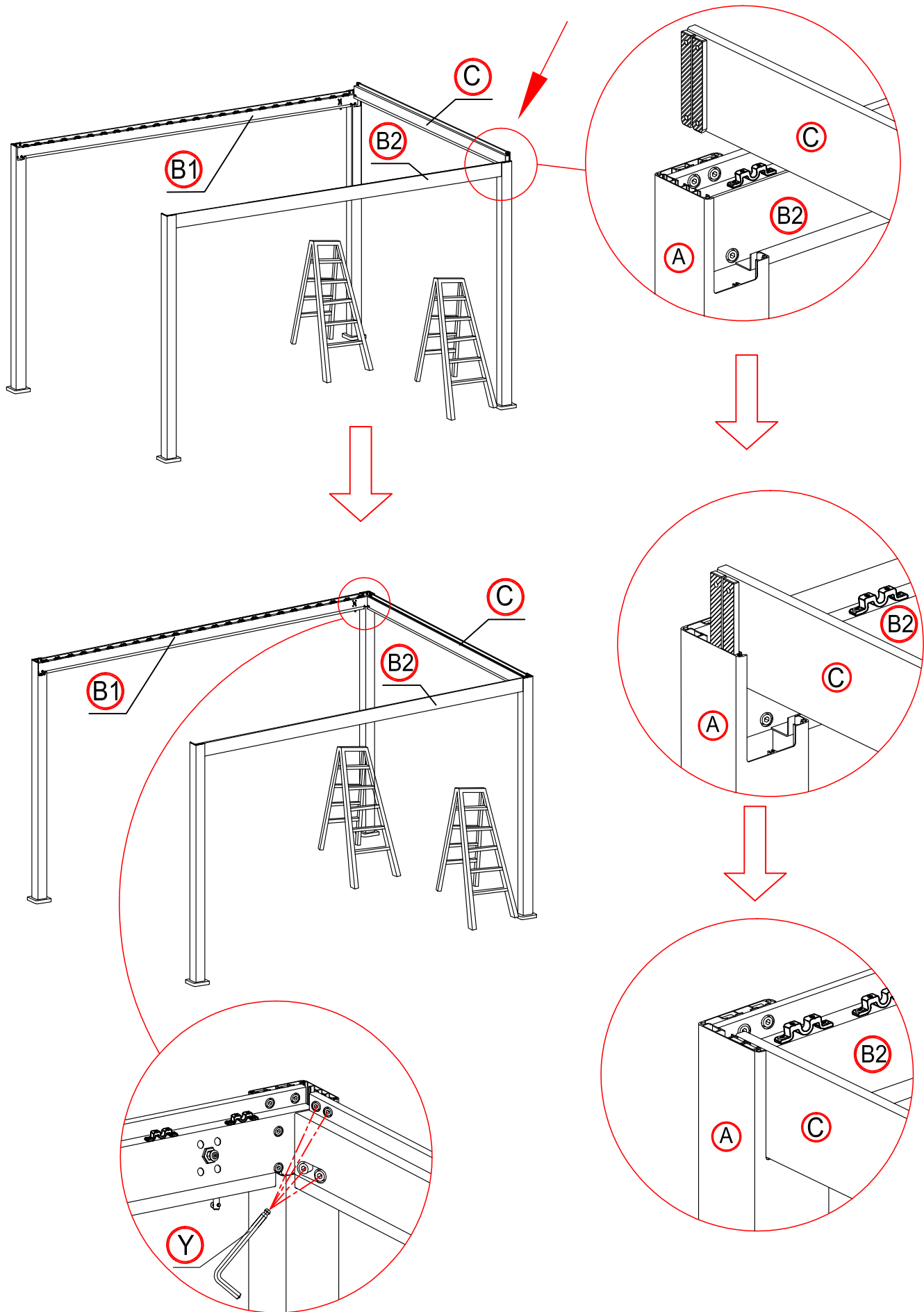

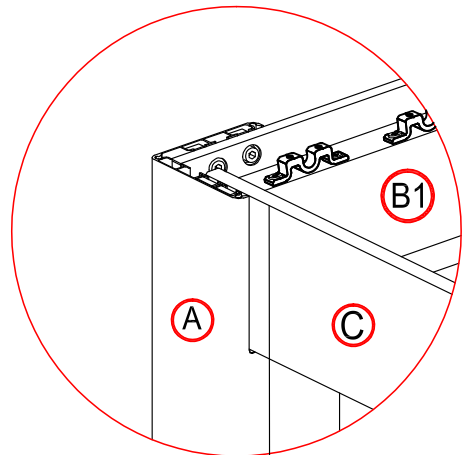
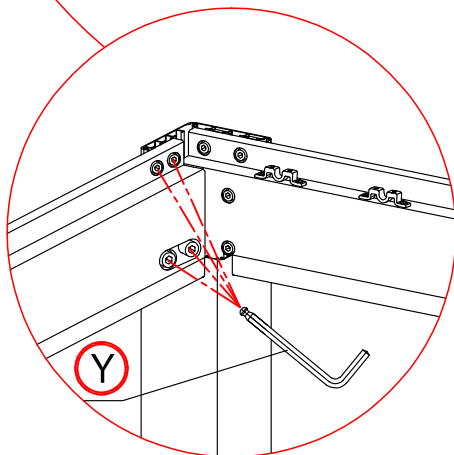
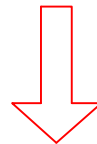
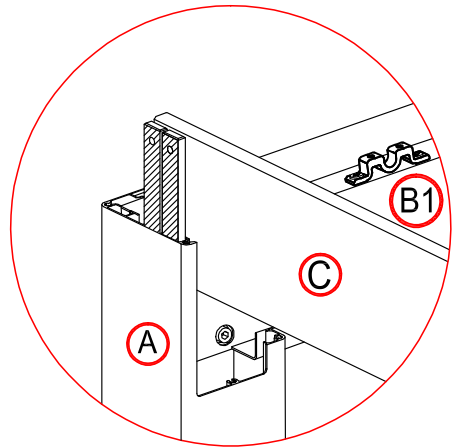
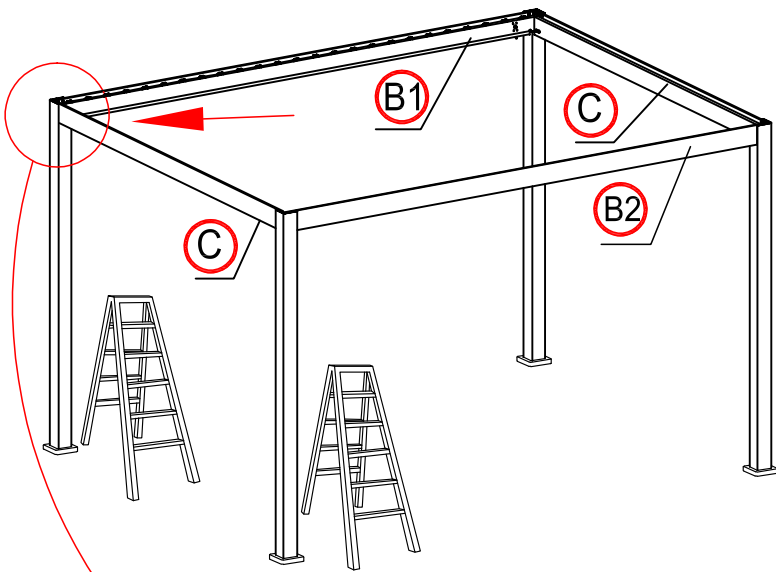
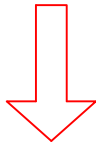
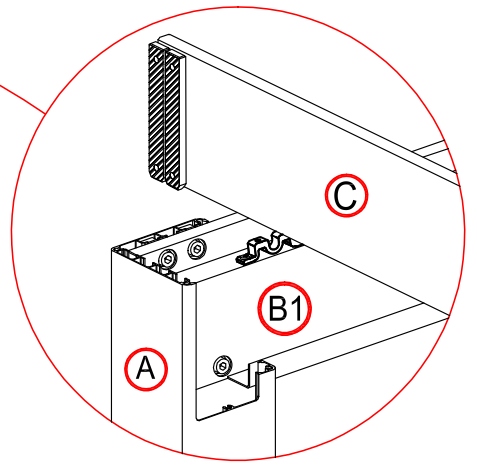
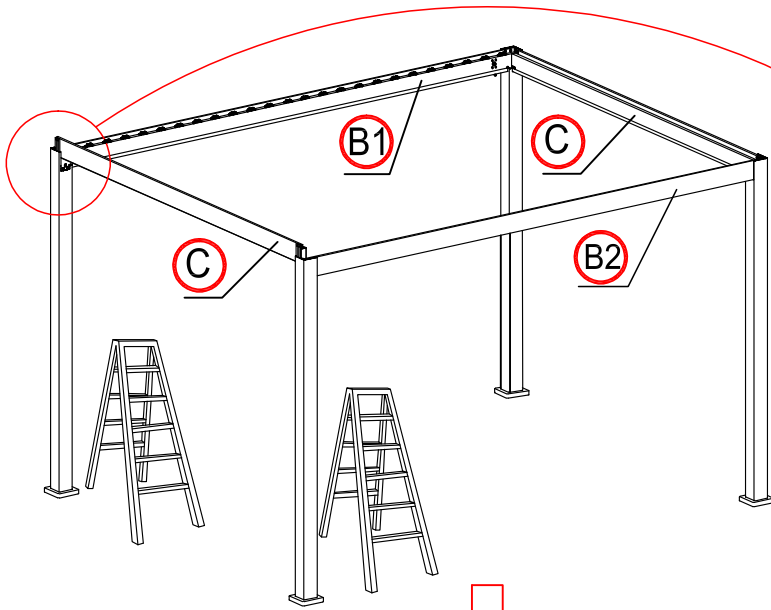

Fije la pieza V en su eje luego agrega la manivela H.

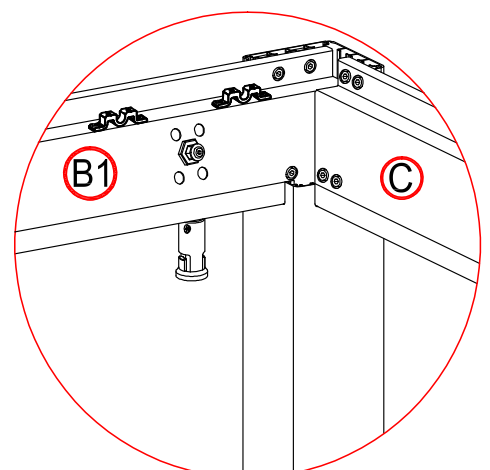
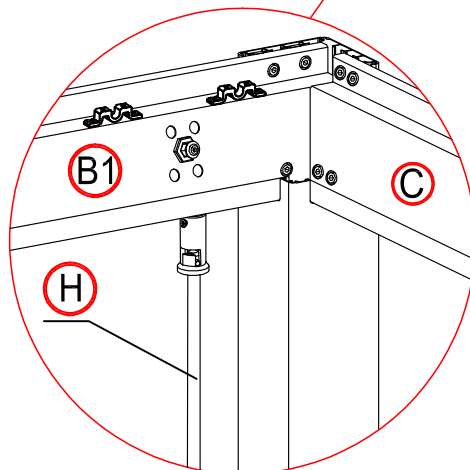
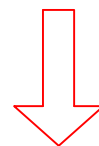
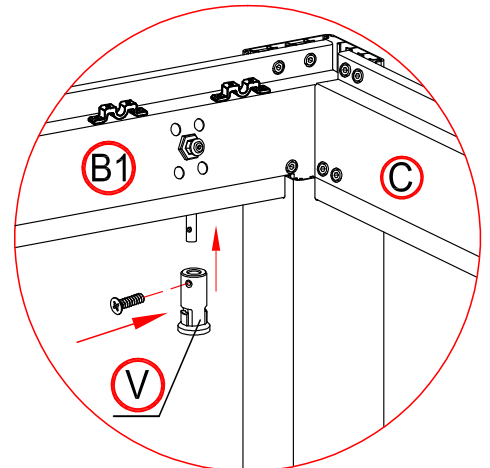
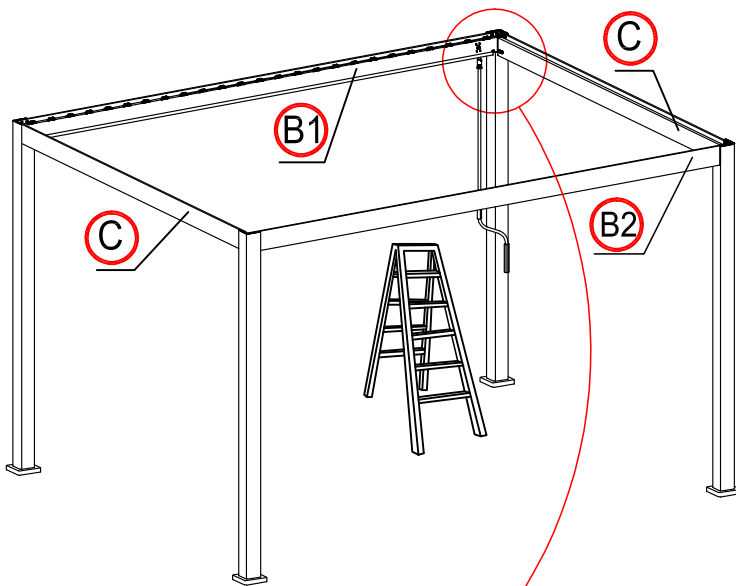
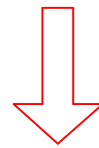
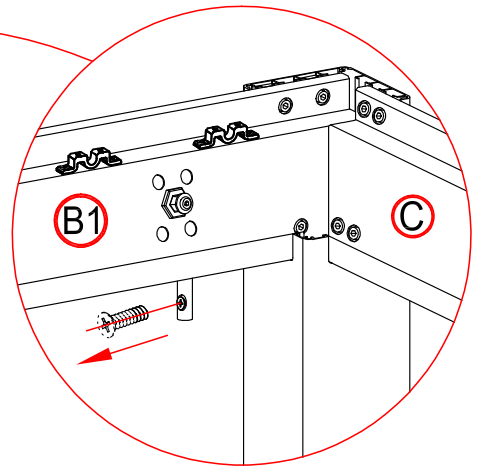
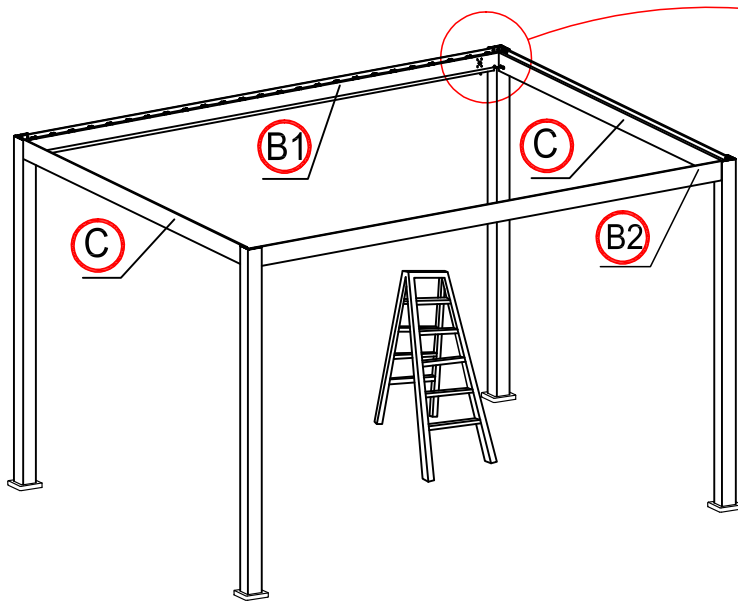

Ensamble la primera lama.
Atornille la parte L en un lado y la parte K en el otro lado.

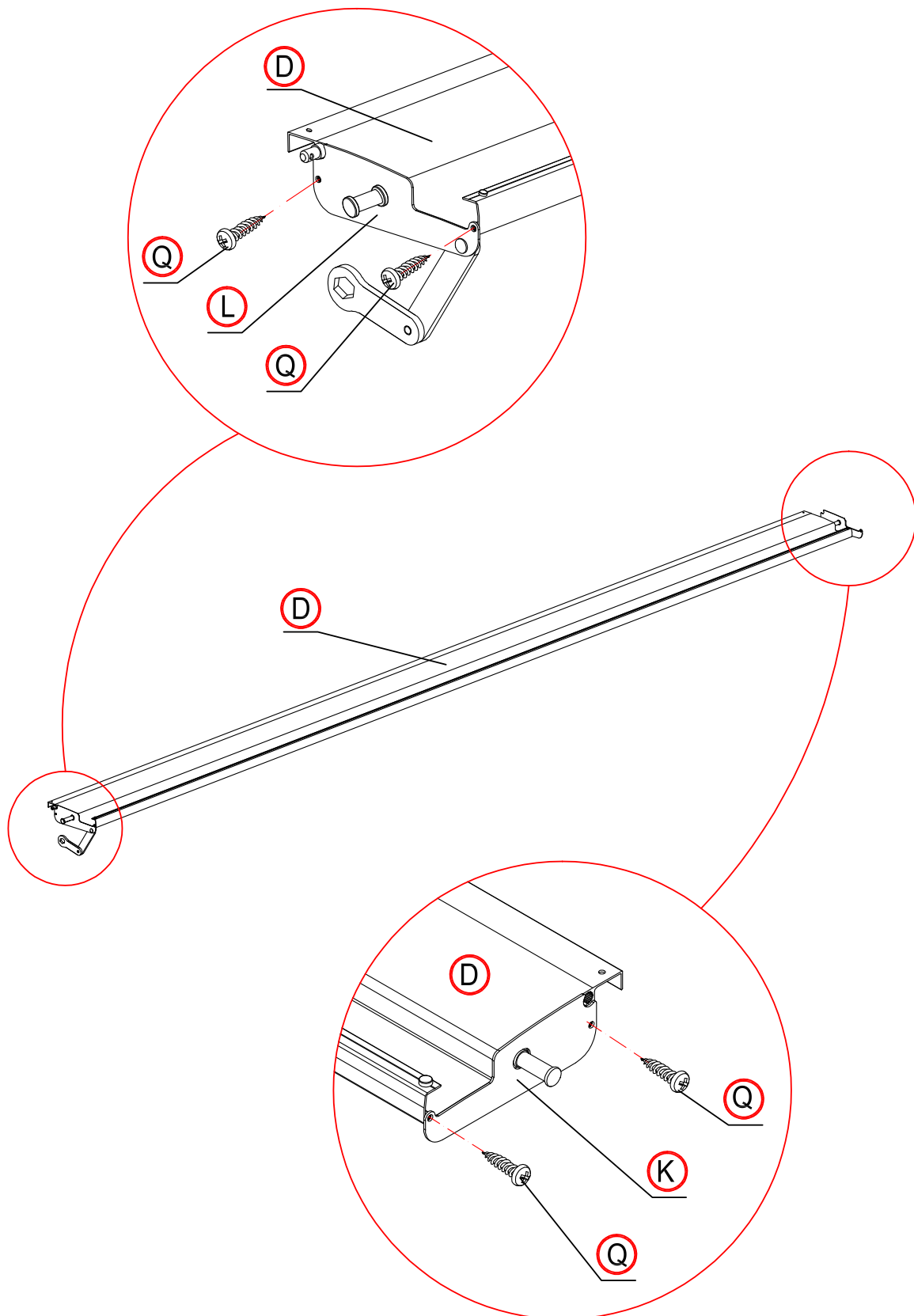

Fije la primera lama a la pérgola en la segunda posición comenzando desde el lado de la manivela.

Inserte el brazo en su alojamiento, la hoja en posición vertical, el brazo debe estar doblado y encajar completamente en el orificio previsto a tal efecto.

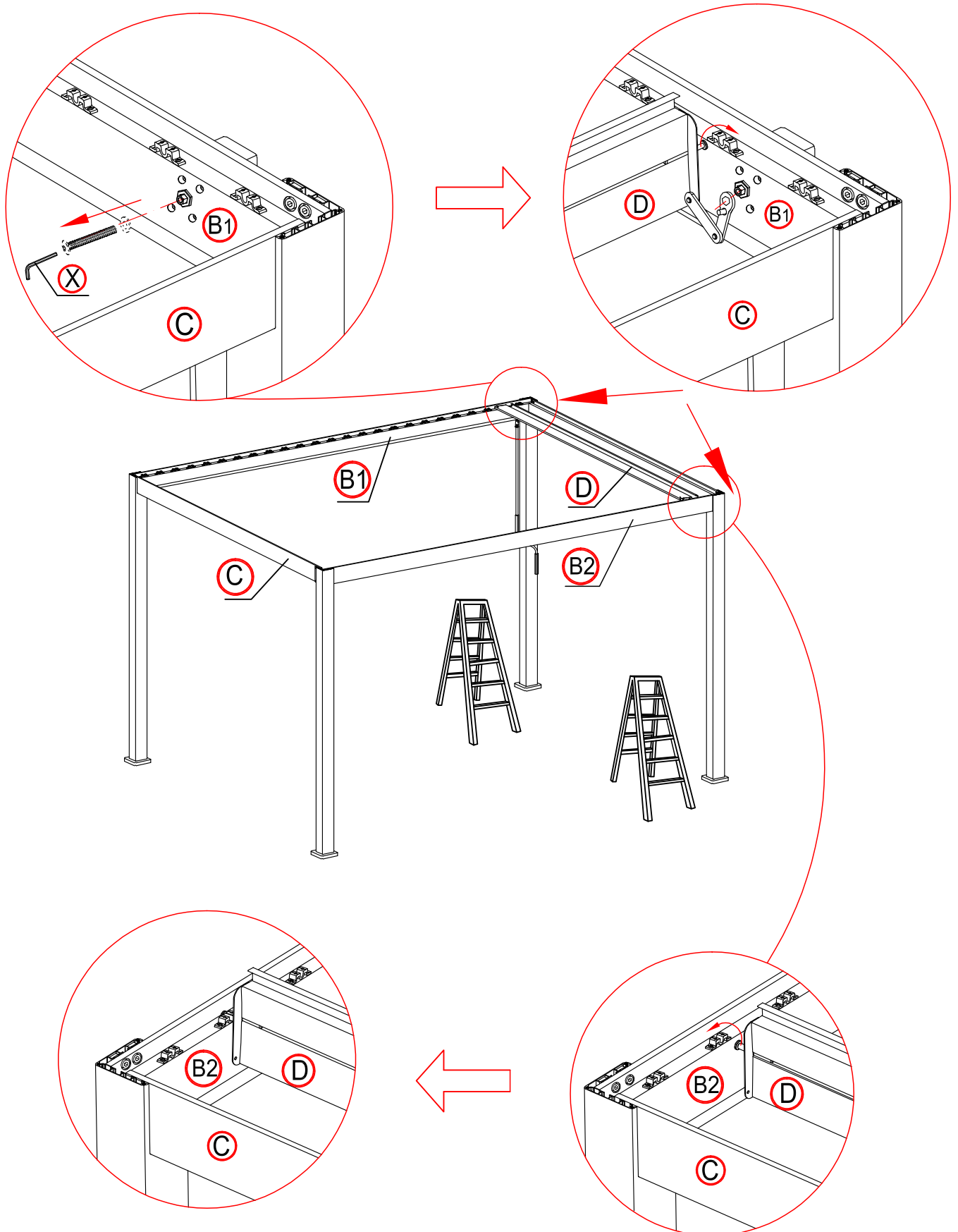

Fije el brazo utilizando el tornillo y la tuerca que se retiraron en el página anterior.

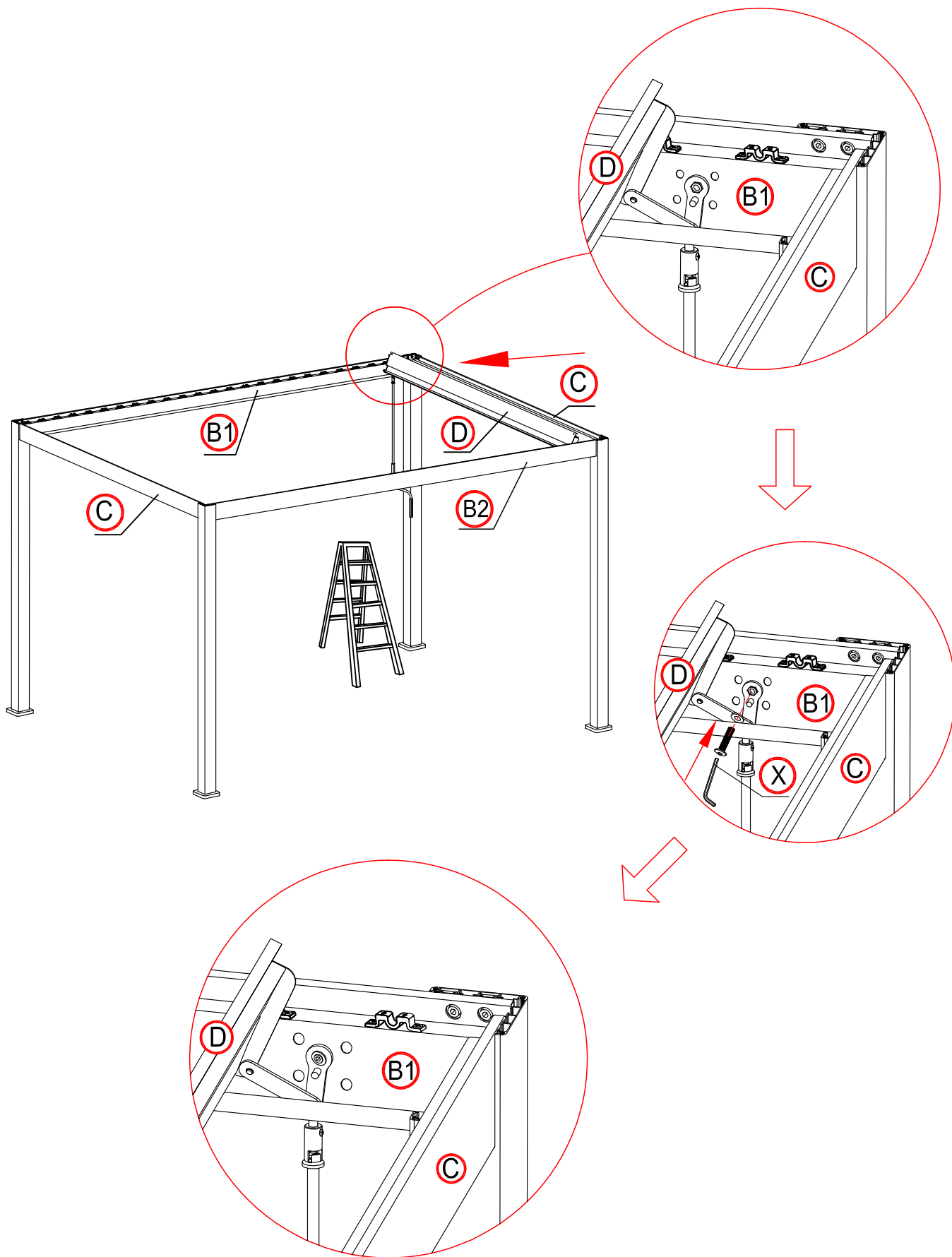

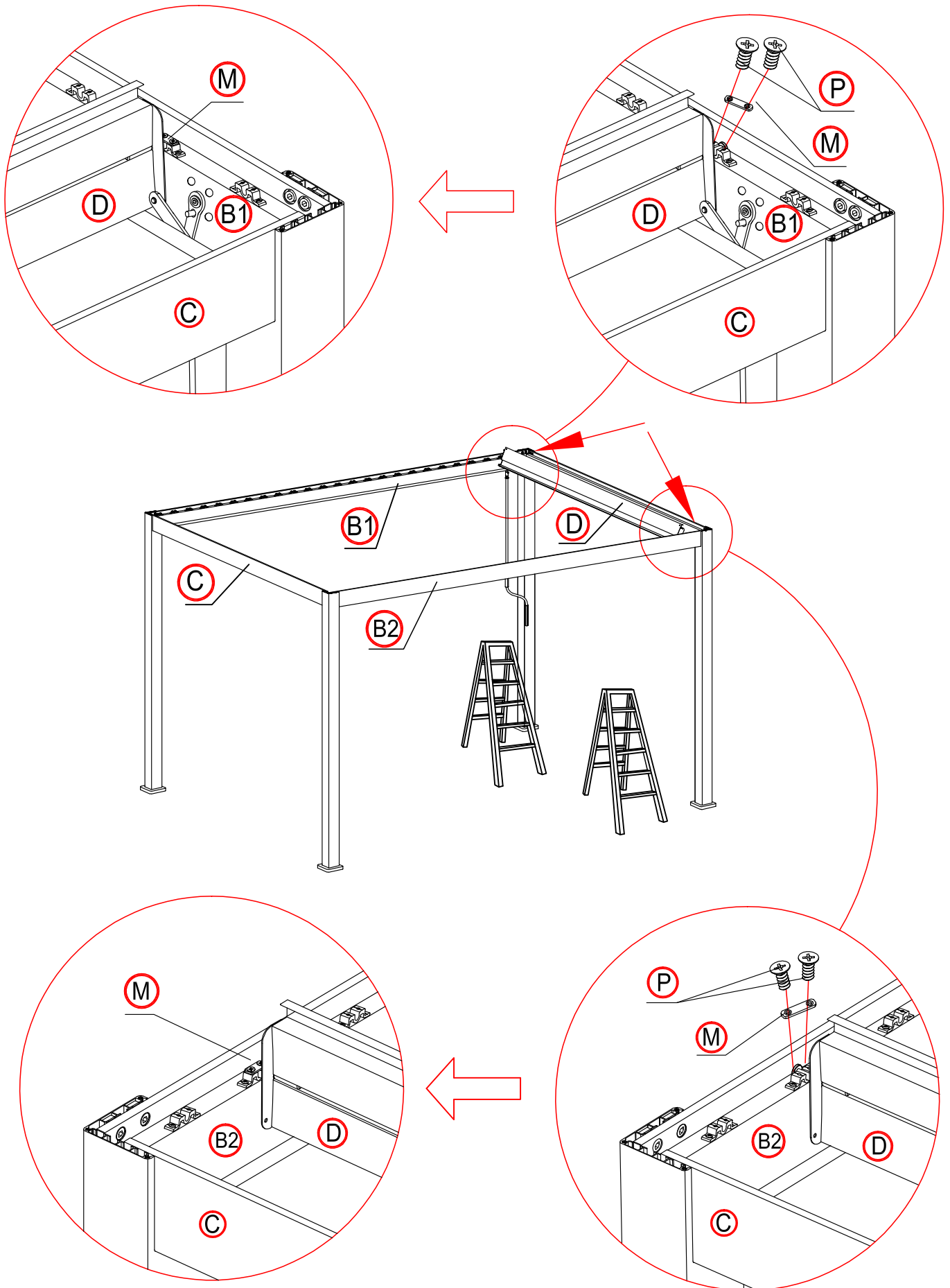

Asegúrese de que la lama funcione correctamente colocándola vertical y horizontalmente en utilizando la manivela H.

Monte las otras 24 lamas sobre una superficie limpia y plana para no estropear la pintura. Comience atornillando ligeramente y luego vuelva a apretar una vez que todos los tornillos estén en su lugar.

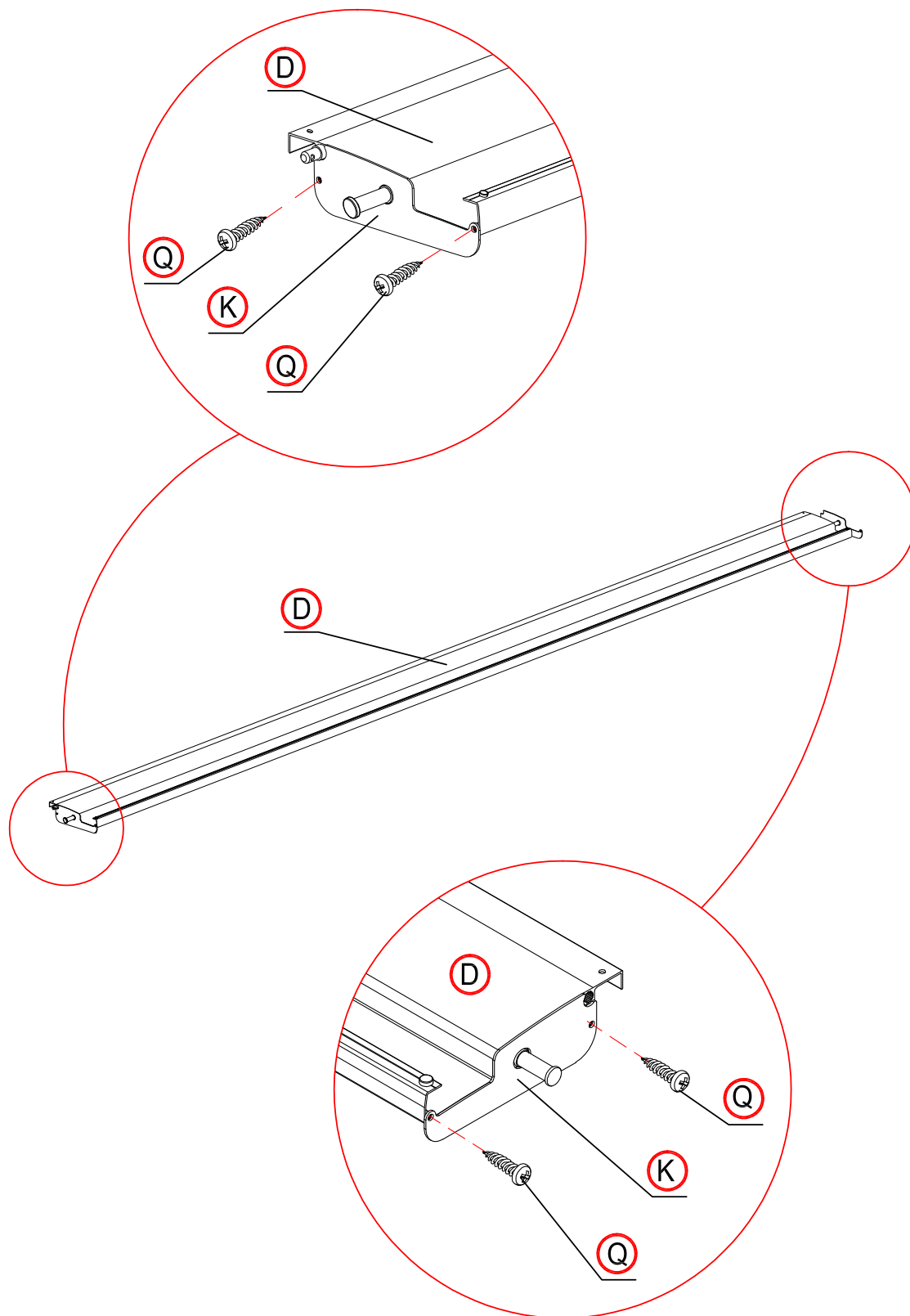

Fije la segunda lama en la primera posición y luego colóquela manualmente en posición horizontal. También coloque la segunda hoja horizontalmente usando la manivela H. Compruebe que las 2 hojas estén bien selladas. Naturalmente, deberían encajar juntos.

Si todo está correcto, fije todas las demás lamas.

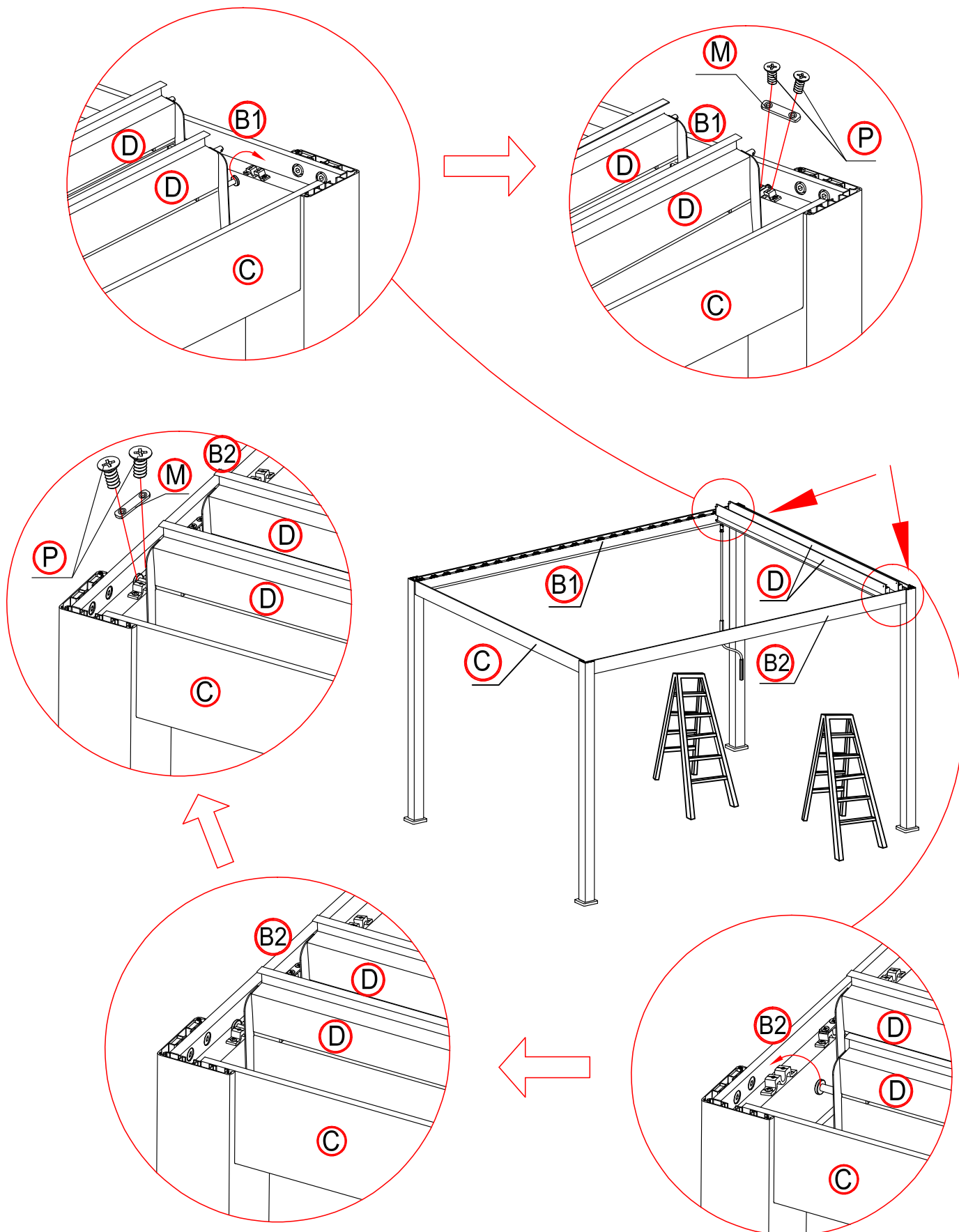

Ensamblar las lamas juntas

Etape 1 : Coloque la segunda hoja verticalmente usando la manivela H.

Etape 2 : Coger la pieza G y pasadores S.

Etape 3 : Coloque la 1ª cuchilla verticalmente, coloque la pieza G (ver diagrama en la página siguiente) e inserte los pasadores S para sujetar las cuchillas. Se requieren 2 personas.

Repita esta operación para fijar todas las placas a la parte G.

Etape 4 : Asegúrese el correcto funcionamiento del mecanismo una vez finalizada la instalación.

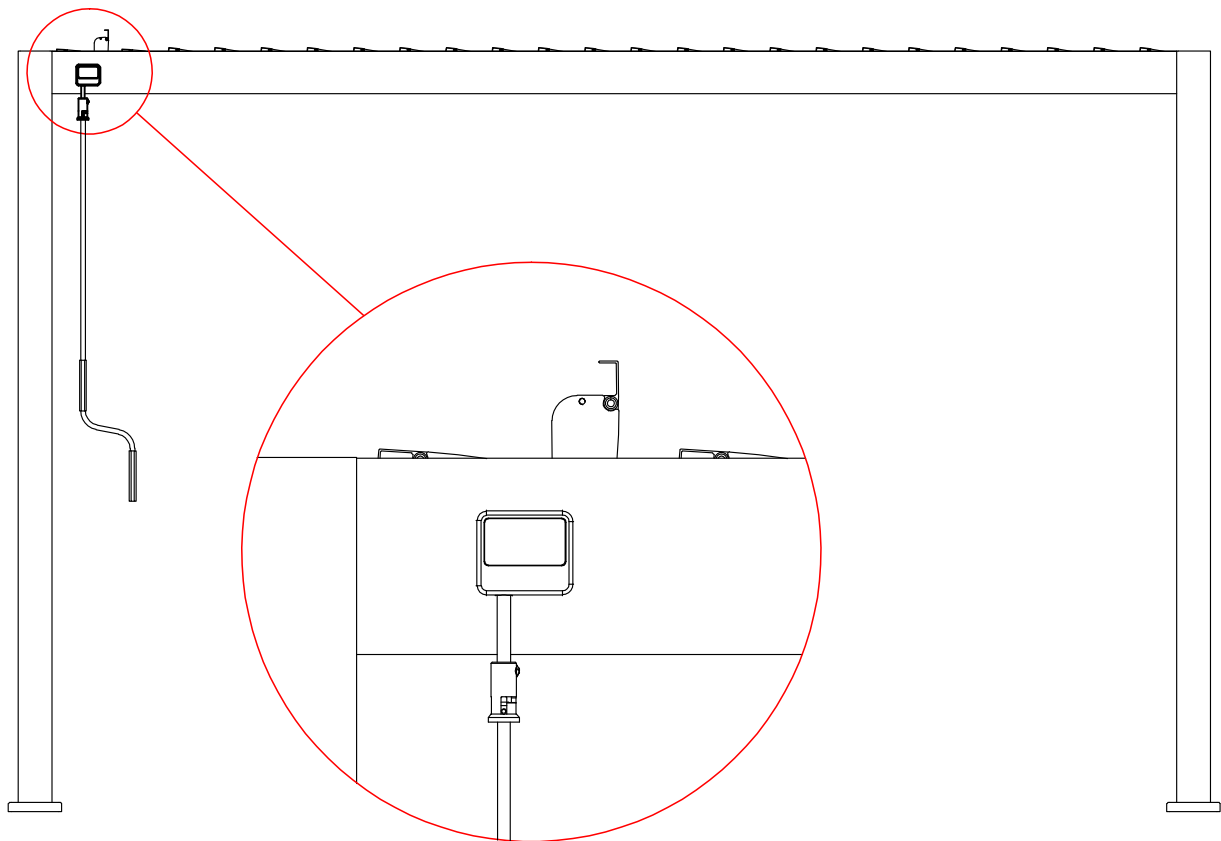

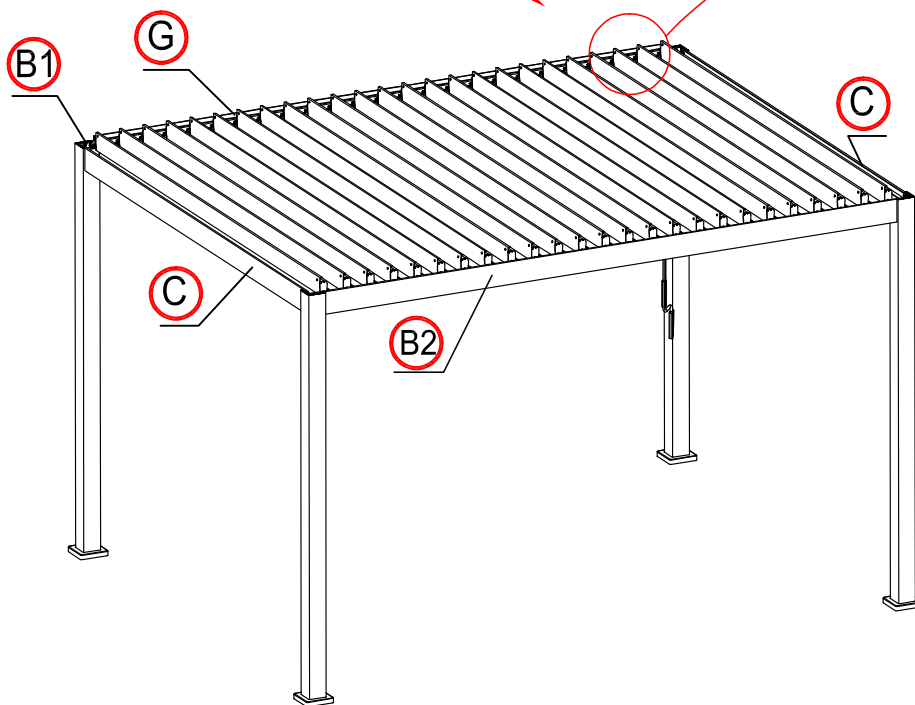
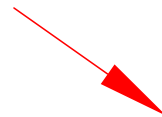
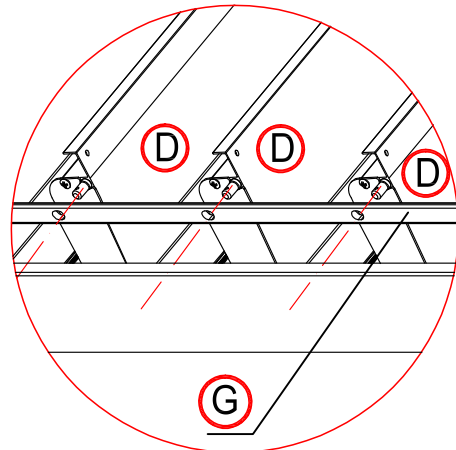
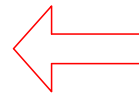
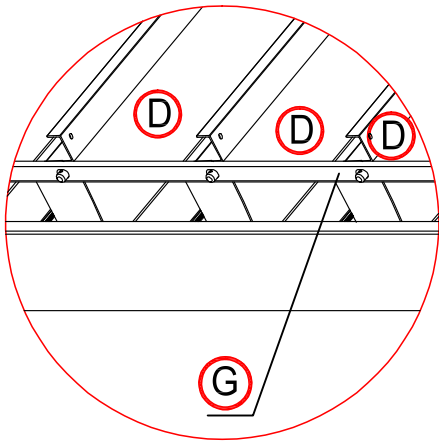
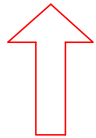
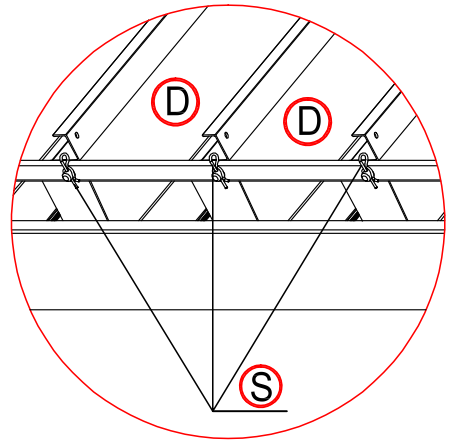
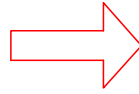
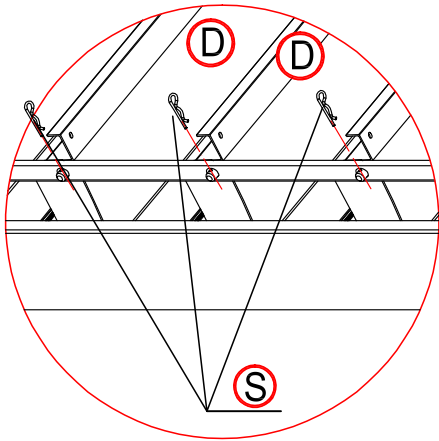

Fije la pieza N en cada ángulo de la pérgola.

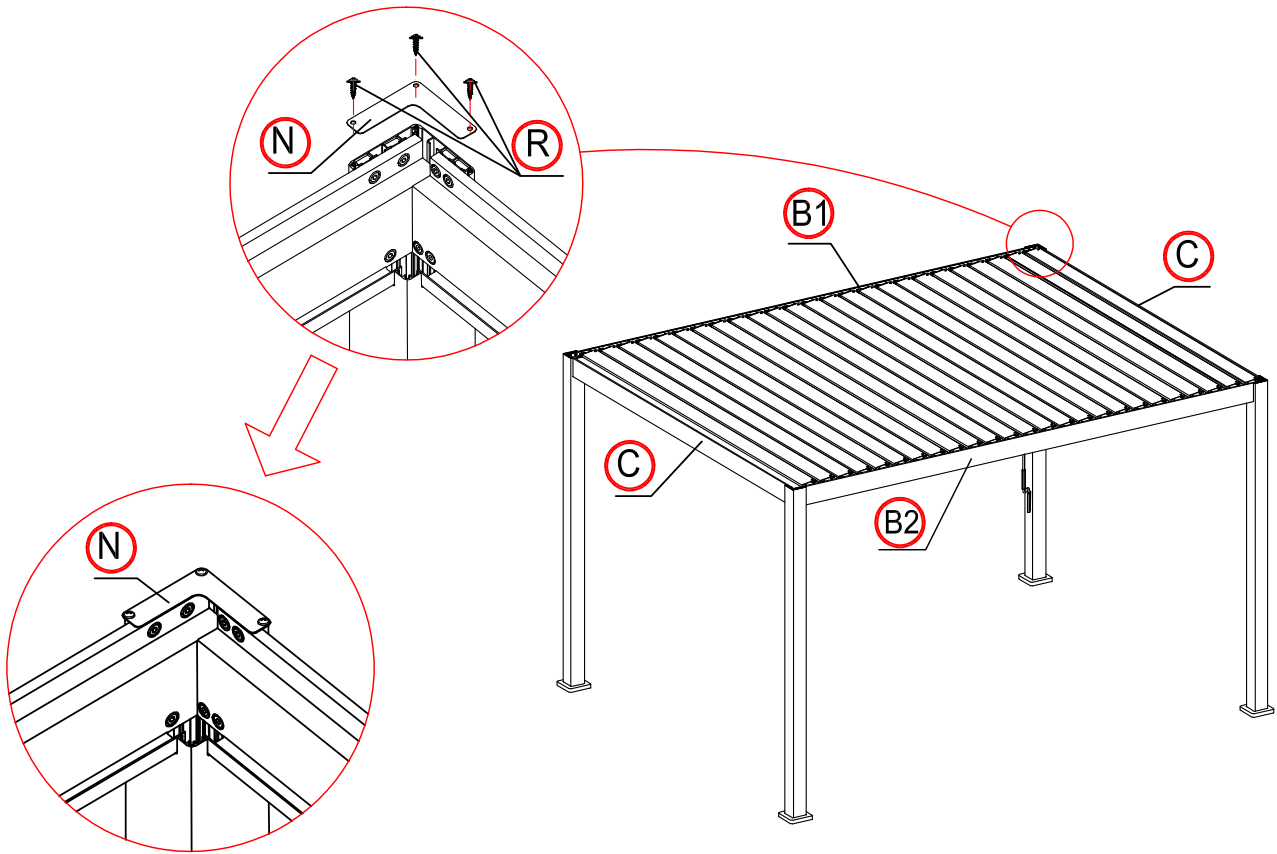

Ancle los 4 pies de la pérgola sobre una base adecuada, estable y nivelada, preferiblemente en hormigón.

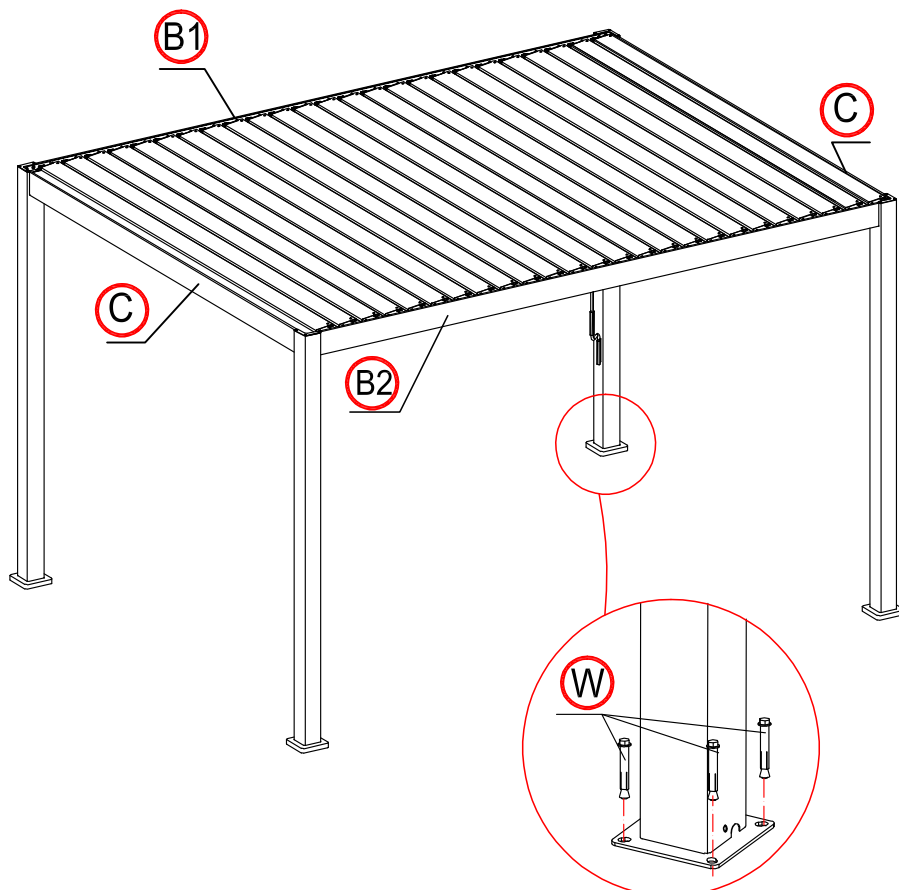

9. PREGUNTAS TECNICAS

Para cualquier duda técnica sobre nuestras pérgolas bioclimáticas, no lo dude póngase en contacto con su distribuidor o consulte nuestra página de preguntas frecuentes en nuestro sitio web: www.pergola-ombrea.com/es

10. ACCESORIOS

Esta pérgola bioclimática 3x4 es compatible con los siguientes accesorios Ombrea®:

LADO DE 4 METROS

ESTORE LATERAL OMBRÉA®

LADO DE 3 METROS

4M
Antracita: 15-709300
Blanca: 15-709317

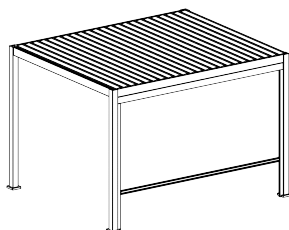

3M
Antracita: 15-709263
Blanca: 15-709270

PANEL LATERAL CON RELIJAS OMBRÉA®

1,3M
Antracita : 15-711532
Blanca : 15-711549



1M
Antracita : 15-710399
Blanca : 15-710405

11. SATISFACCIÓN

Conocer su opinión nos ayudará a seguir mejorando, por eso, no dude en contarnos para enviarnos sus comentarios / sugerencias a la siguiente dirección: contact@pergola-ombrea.com.

Estaremos encantados de recibir las fotos de su instalación.

Le agradecemos su compra y le deseamos días felices bajo su pérgola.

Self-supporting Bioclimatic Pergola 3x4M

These instructions have to be saved during the whole product life cycle.

We advise you to read these very carefully before proceeding to the assembly.

The user will be reliable for any damages or injuries caused due to incorrect or improper installation.

1. PRECAUTION FOR USE

This product should not be used in extreme weather: storms, violent winds, hail and snow. We guarantee the resistance of the pergola for winds up to 110 km/h and a maximum snow weight of 55kg/m².

As in the case of strong winds or snow, we highly recommend leaving the blades open. In the case of omission or neglect the pergola will have to be cleared of any snow in order to avoid any overload on the blades.

Our pergola can withstand heavy rain, but we cannot guarantee it will be 100% waterproof. Exceptional climatic events, may compromise the perfect sealing of the product. We advise you not to leave products that are sensitive to humidity under the pergola.

We do not recommend climbing on the roof or on the structure of the pergola, risking damages and may cause injuries.

2. INSTALLATION TIPS

Depending on the location and surface area, constructions may be subject to building permits. We invite you to contact your city hall to obtain the needed information before the assembly.

Product assembly

- 2 to 3 people are required.
- Do not keep children near the assembly area.
- Beware of the risk of pinching.
- Only tighten screws halfway before assembling the whole product.
- All assembly steps must be carefully followed.

No changes can be made to the product. If products are modified by the user we will be in our rights to not honor the terms of our warranty, thus being declared as void. The location should be chosen appropriately. It is recommended to avoid mounting your pergola facing the prevailing winds and under a tree.

The pergola must be mounted on a stable foundation. It is recommended to install it on a concrete slab or on concrete blocks at each post. We ask you to anchor the pergola properly to the ground using the W pieces.

If you would like to mount your pergola near your house or a building we ask you to check the presence of gutters for water drainage. We cannot guarantee that the pergola Ombrea can insure a perfect sealing if rainwater from your gutter lines spill on it.

Should these instructions not be followed or only partially, the warranty will be voided by the seller

3. MAINTENANCE OF THE PERGOLA

Regular maintenance is necessary to ensure its longevity and aesthetic appearance, we recommend to :

- Wash your pergola once or twice a year with fresh water using a sponge or cloth.
- Do not use an aggressive product or an abrasive surface.
- Check the tightness of the screws regularly (at least once a year).
- Oil the hardware regularly (at least once a year).
- Make sure that nothing hinders the water flow in the gutters (leaves, branches...).
- Remove any water that might stagnate around the legs of the pergola (lift the protections).

4. WARRANTY

Ombrea® guarantees the availability of its spare parts for 2 or 5 years (depending on the product). The guarantee only applies if the storage, assembly, use and maintenance instructions are respected

This warranty does not cover:

- Normal wear and tear inherent from the products.
- Loss or breakage of any part during unpacking or installation.
- Lack of reasonable care, neglect, vandalism, impact with foreign objects, force, and contact with force, contact with abrasives, cosmetic, disassembly, rebuilding or relocation.
- Major forces: hail, high winds, storms, snow, floods, lightning...

The warranty only takes in account the replacement of spare parts or the provided product, no refund will be issued.

All warranty claims must be made at the sales outlet (store or website) where the product has been bought.

5. LIST OF PARTS PER BOX



Before proceeding with the assembly of your panel, it is necessary to verify that all parts are present and not damaged.



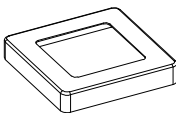
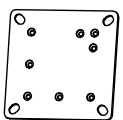
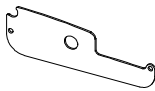
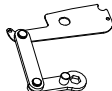
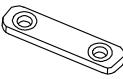
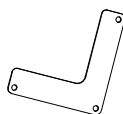
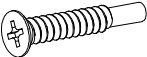

Any missing part must be reported within 30 days of delivery. You can either go through your local outlet store or make the request directly on our website sav.comintes.com

Do not discard the packaging without ensuring that the panel is functioning properly.

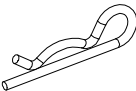
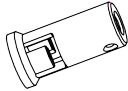

CARTON 1/4 (FEET AND HARDWARE)

Reference	Diagram	Quantity
A		4

Reference	Diagram	Quantity
I		4
J		4
K		51
L		1
M		52
N		4
O	 ST5.65x45	24
P	 M5x12mm	104
Q	 4.2x25mm	104

Reference	Diagram	Quantity
R	 5.5x19mm	12
S		29
V		1
W	 M8 x 80	16
X		1
Y		2

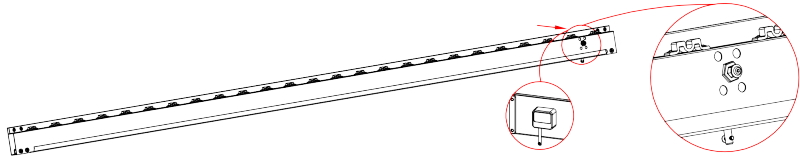
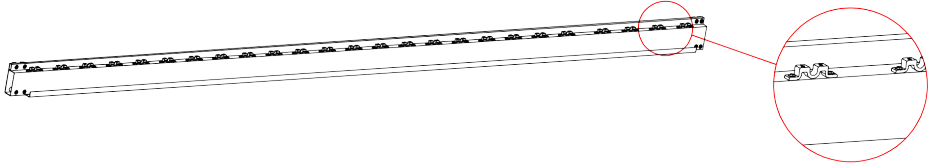
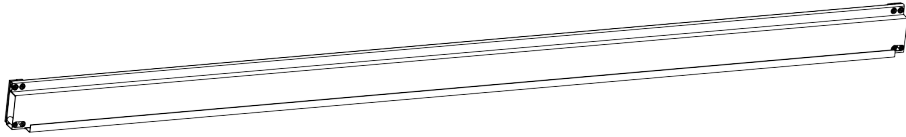
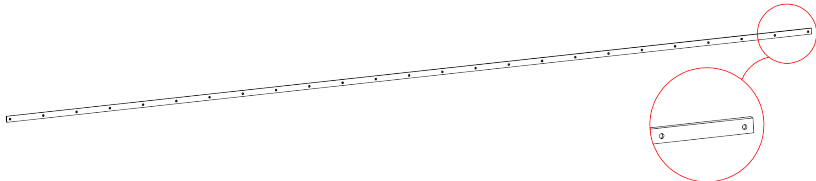
CARTON 2/4 (TOP FRAME)

Reference	Diagram	Quantity
B1		1
B2		1
C		2
G		1
H		1

CARTON 3/4 (BLADES)

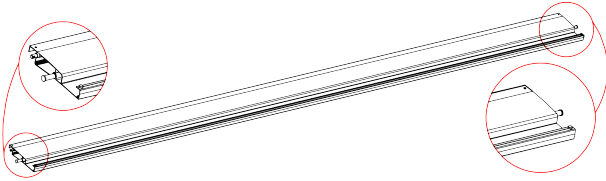
Reference	Diagram	Quantity
D		13

CARTON 4/4 (BLADES)

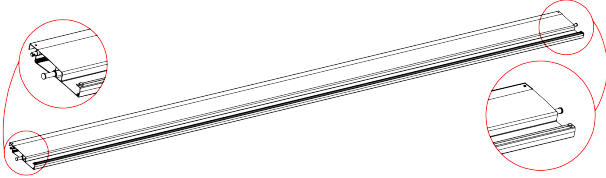
Reference	Diagram	Quantity
D		12

6. MATERIAL (NOT SUPPLIED) NEEDED FOR THE ASSEMBLY

- Gloves
- Cutter
- Mallets
- Safety helmets
- Measuring tape
- Electric screwdriver
- Drill
- Ladders/stepladders

7. ASSEMBLY PLAN (dimensions in mm)

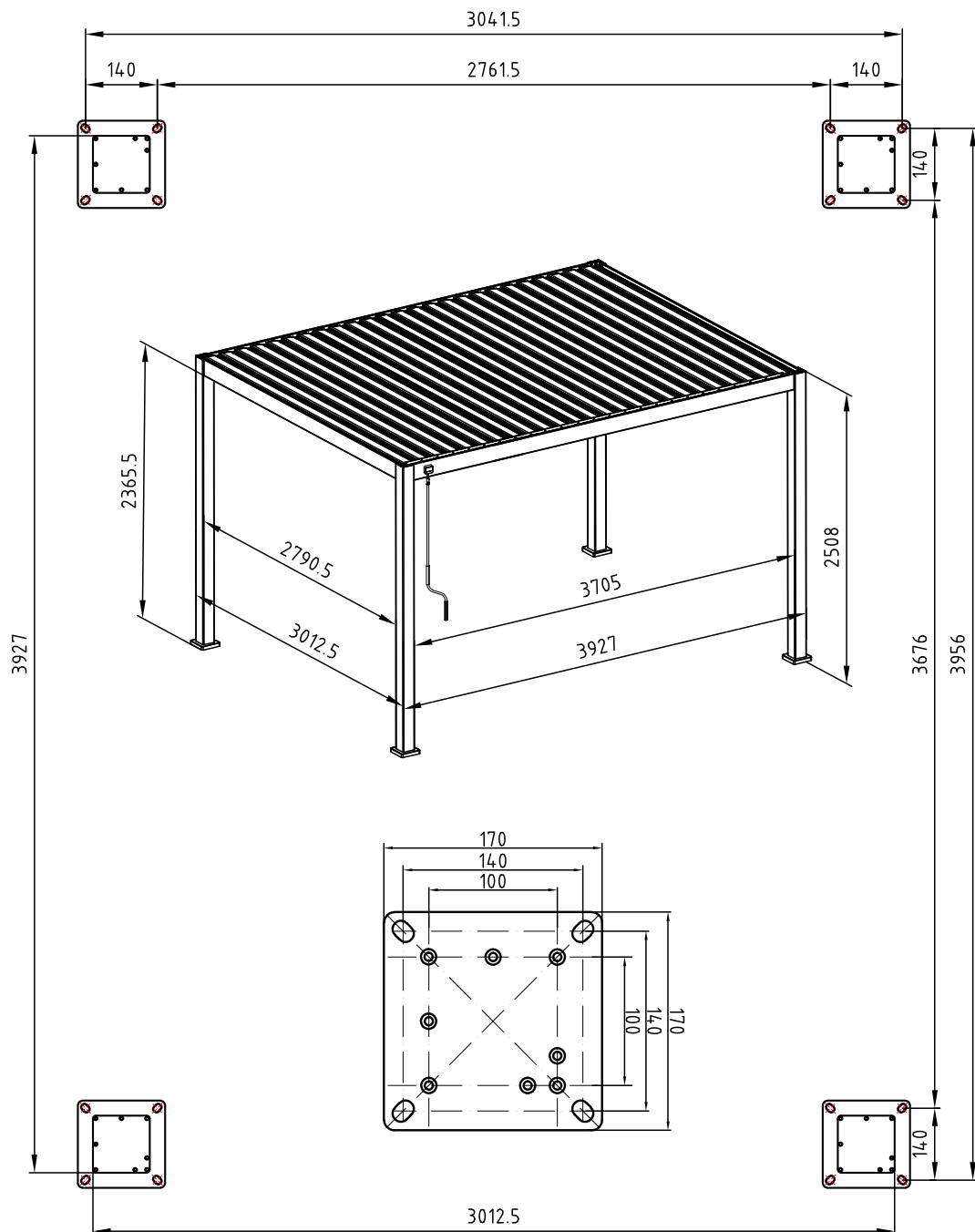

8. ASSEMBLING STEPS

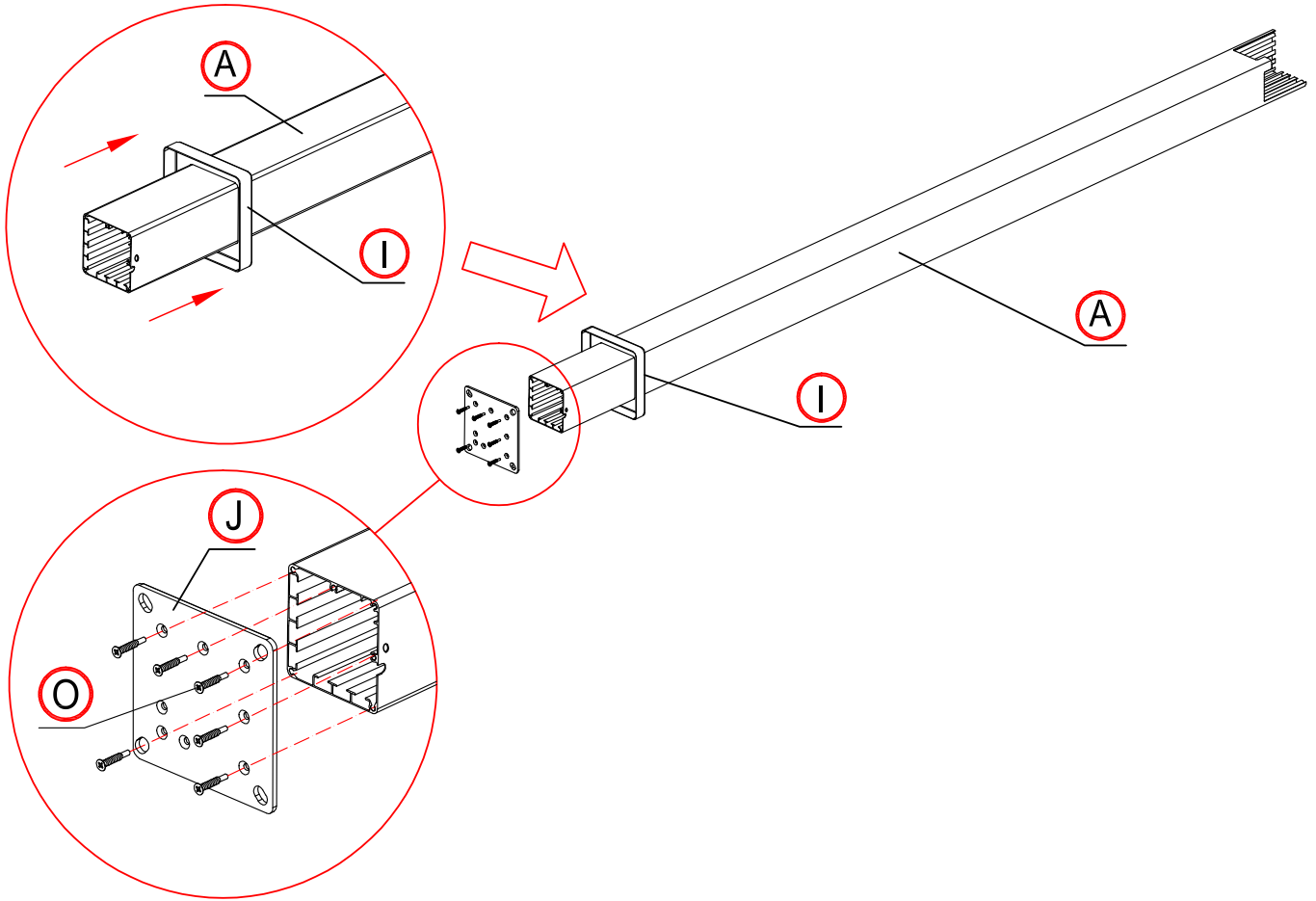

Slide the covers I on the 4 poles then position the plates J under the 4 poles as well.

To avoid damaging the paint, we recommend that you assemble them on a table or on a clean flat surface.

Attach the O-screws with a screwdriver. Start by tightening lightly and then fully once all the screws of the pergola are in place.

Loosen the metal plates at both ends of the B1 beam (do not unscrew them completely).

Insert the beam B1 into the posts A simultaneously on both sides. The metal plates must slide into the grooves of the posts.

Tighten the metal plates using tool Y.

Repeat the same operation for beams B2 and C.

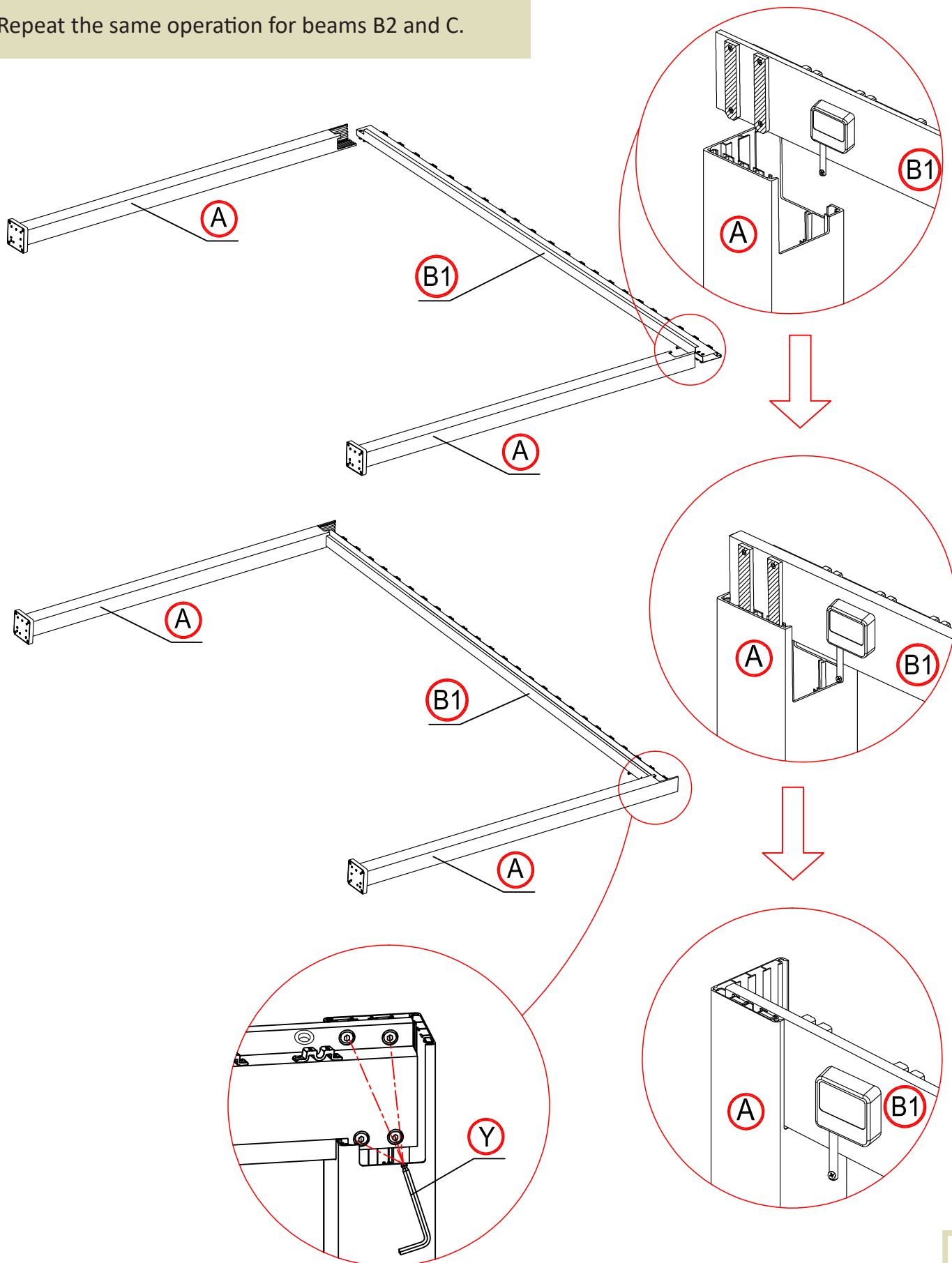

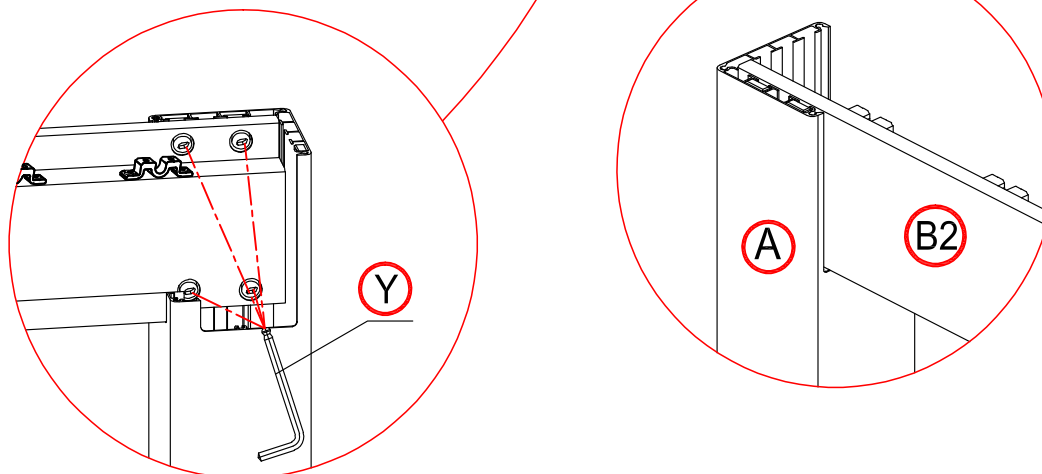
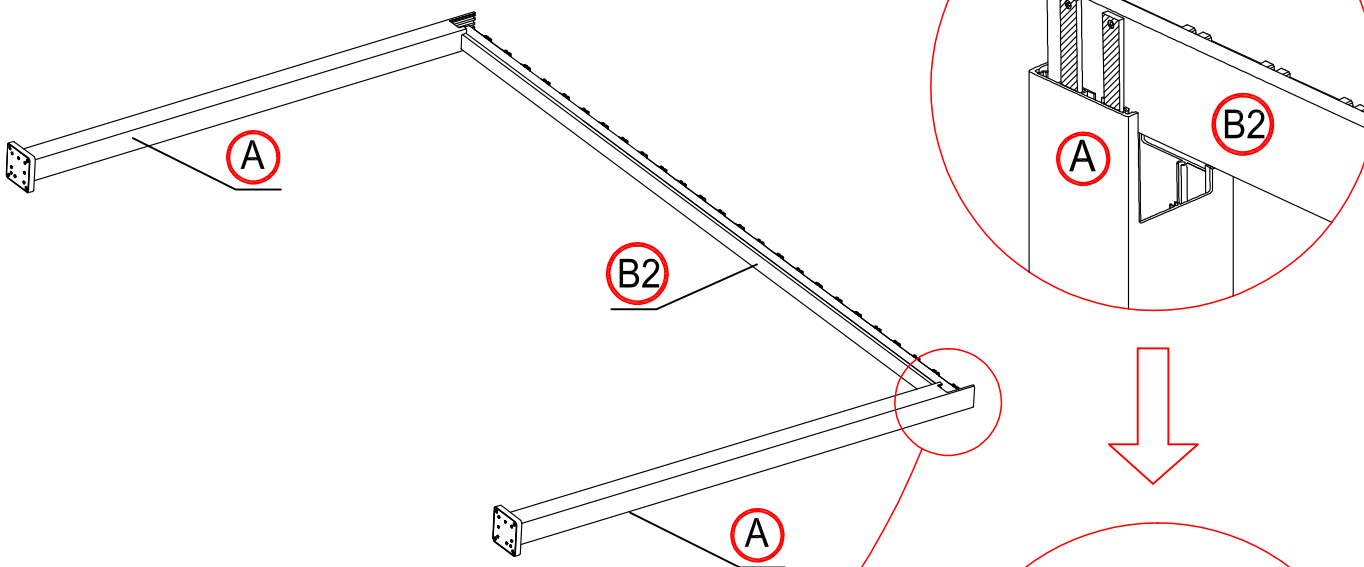
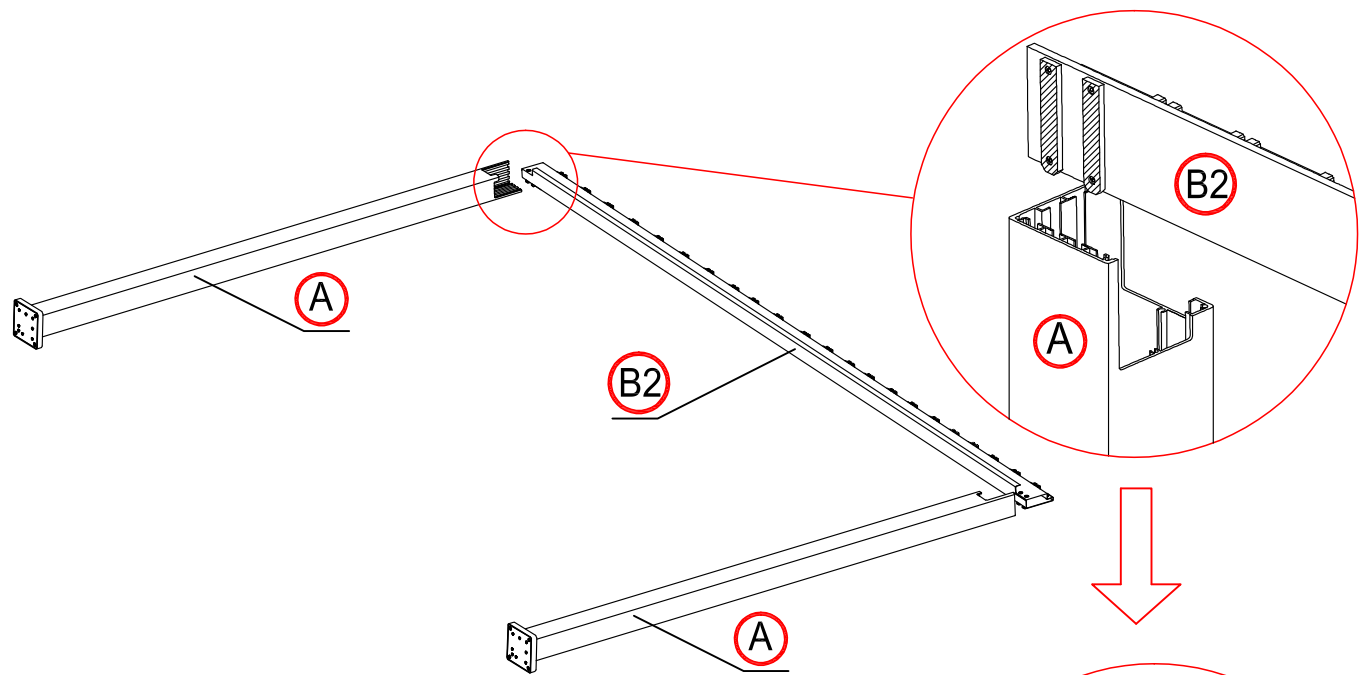

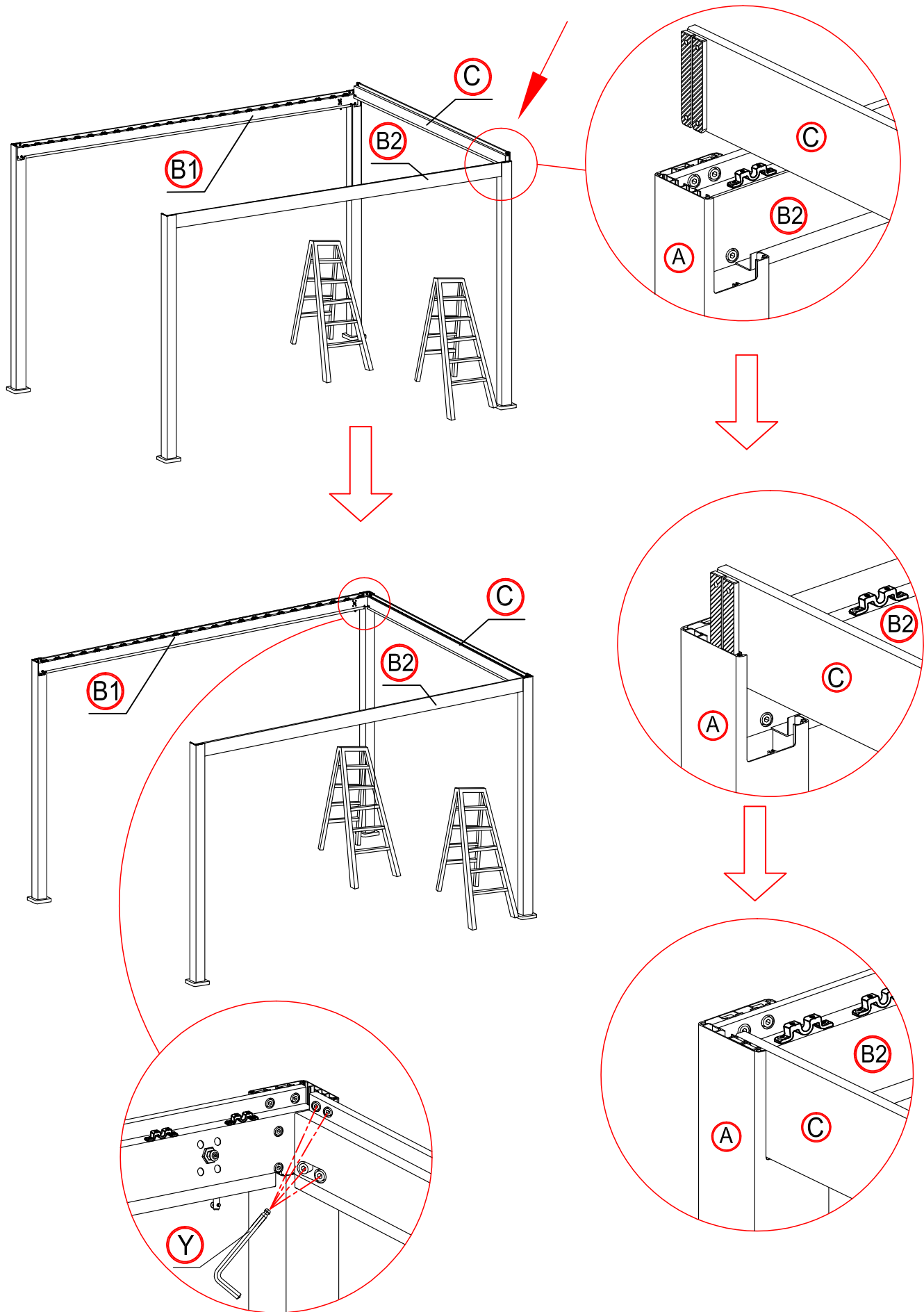

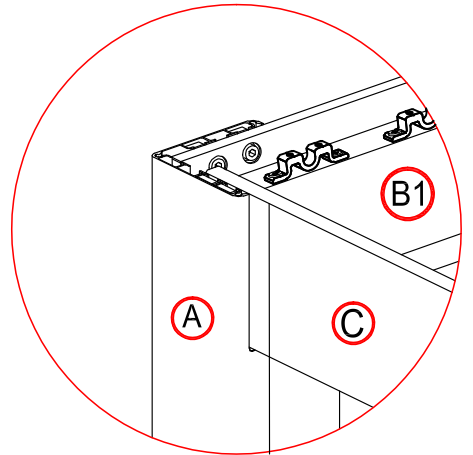
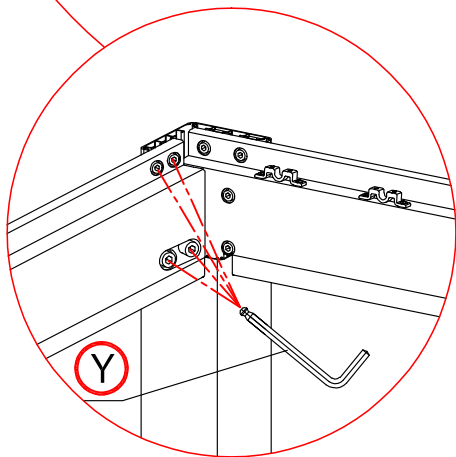
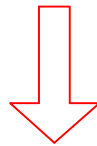
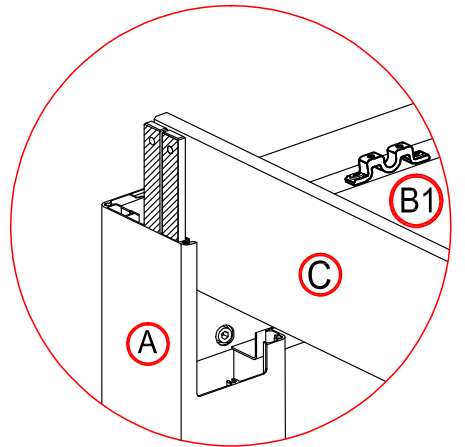
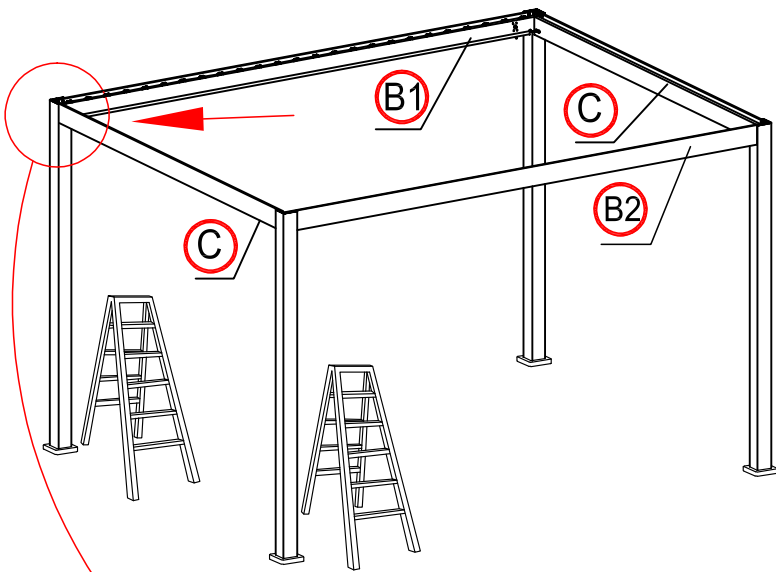
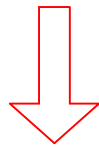
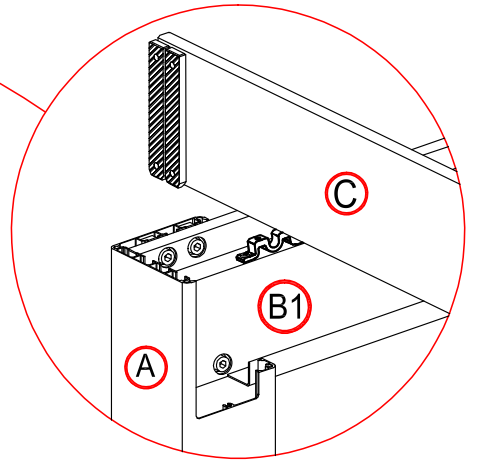
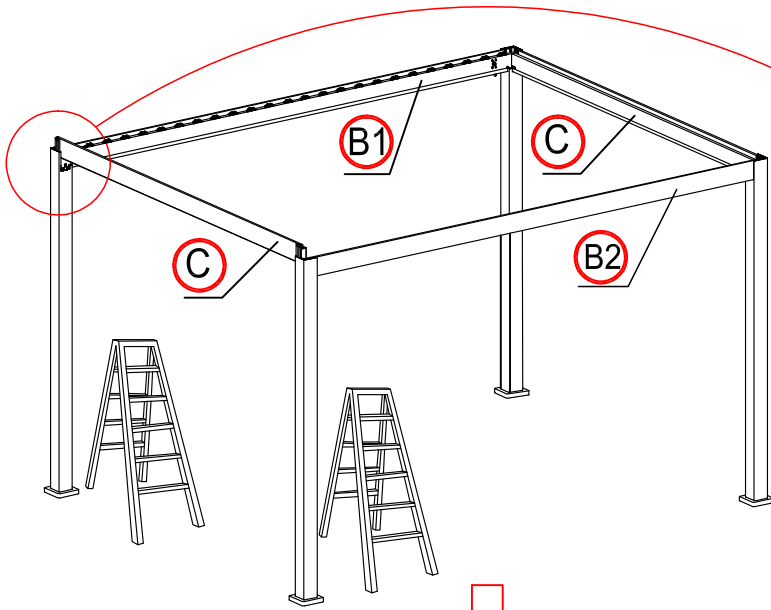

Fix the part V on its axis, then add the handle H.

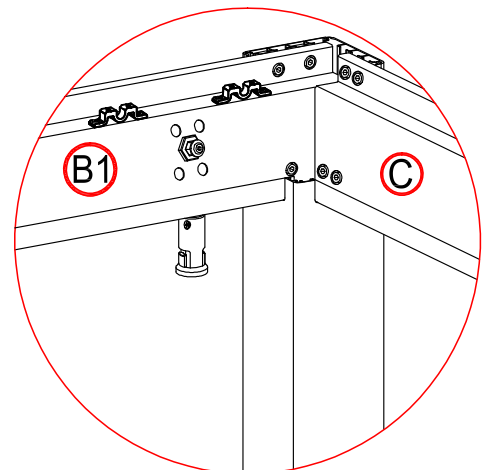
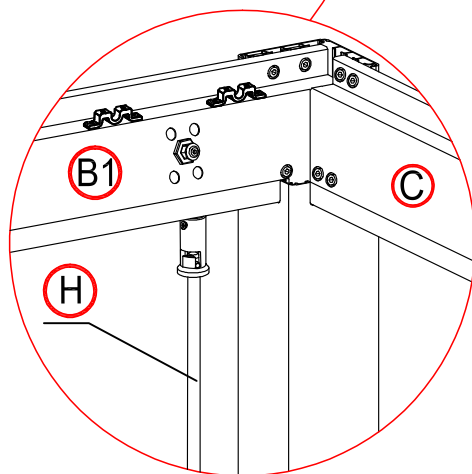
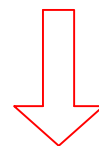
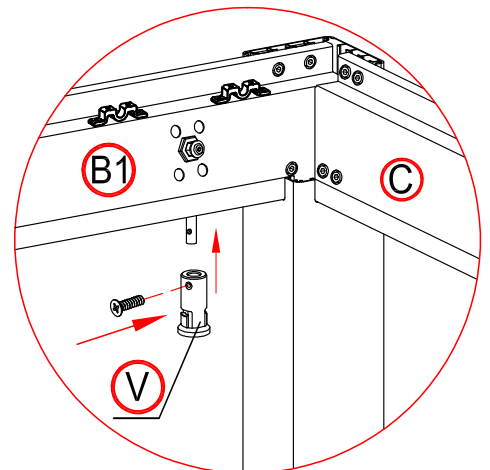
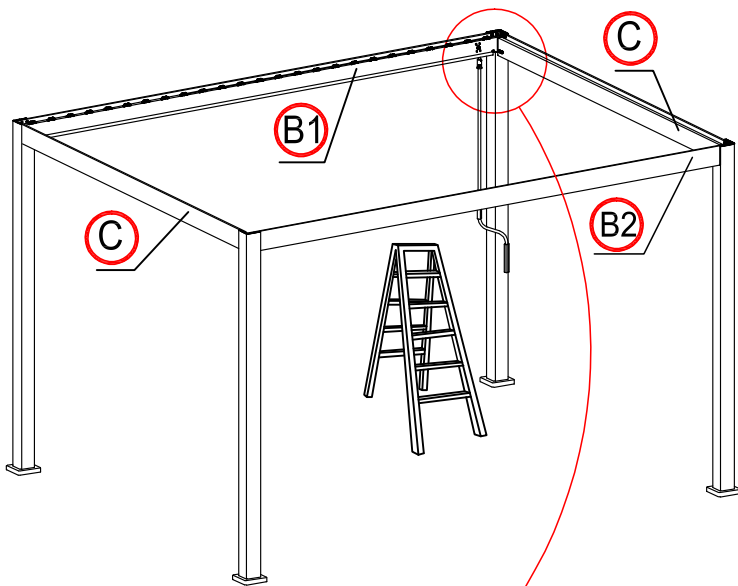
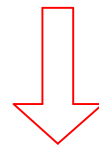
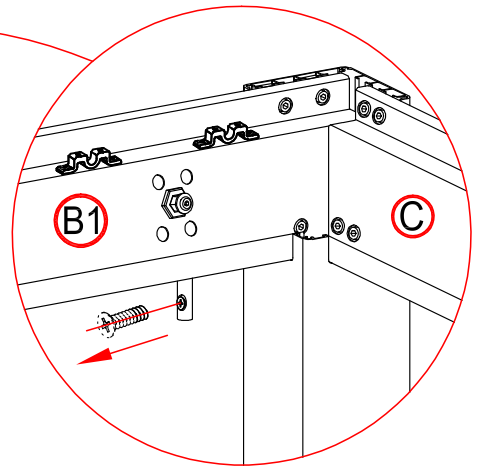
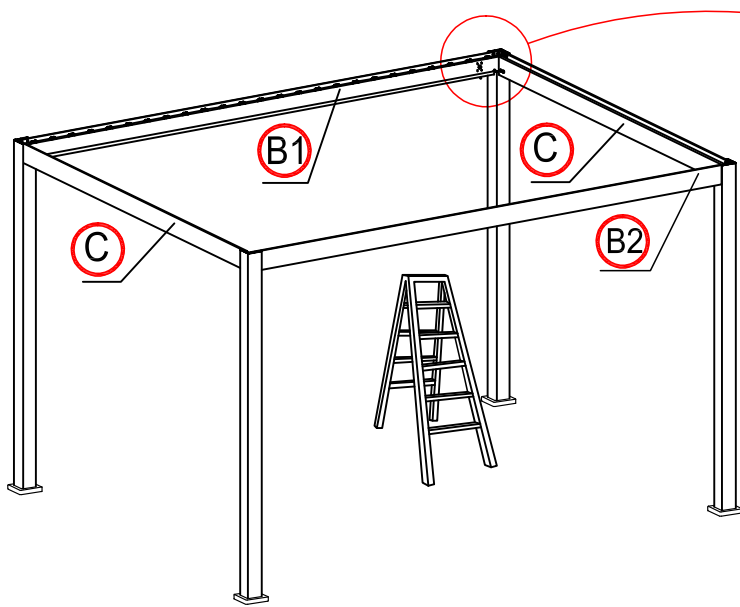

Assemble the first blade.
Screw part L on one side and part K on the other side.

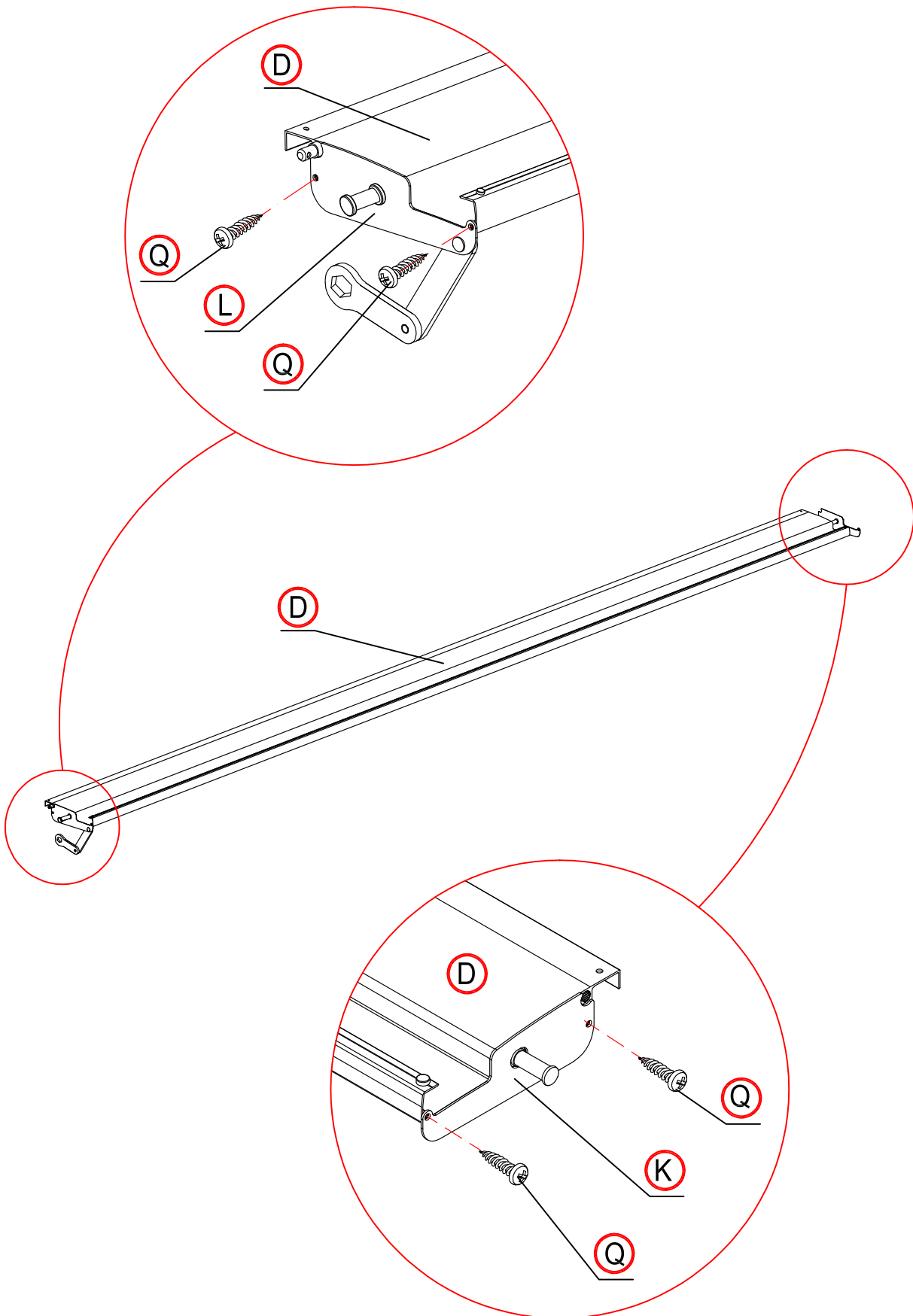

Attach the first blade to the pergola in the second position, starting from the handle side.

Insert the arm in its housing, the blade in vertical position, the arm must be folded and enter completely in the hole provided for this purpose.

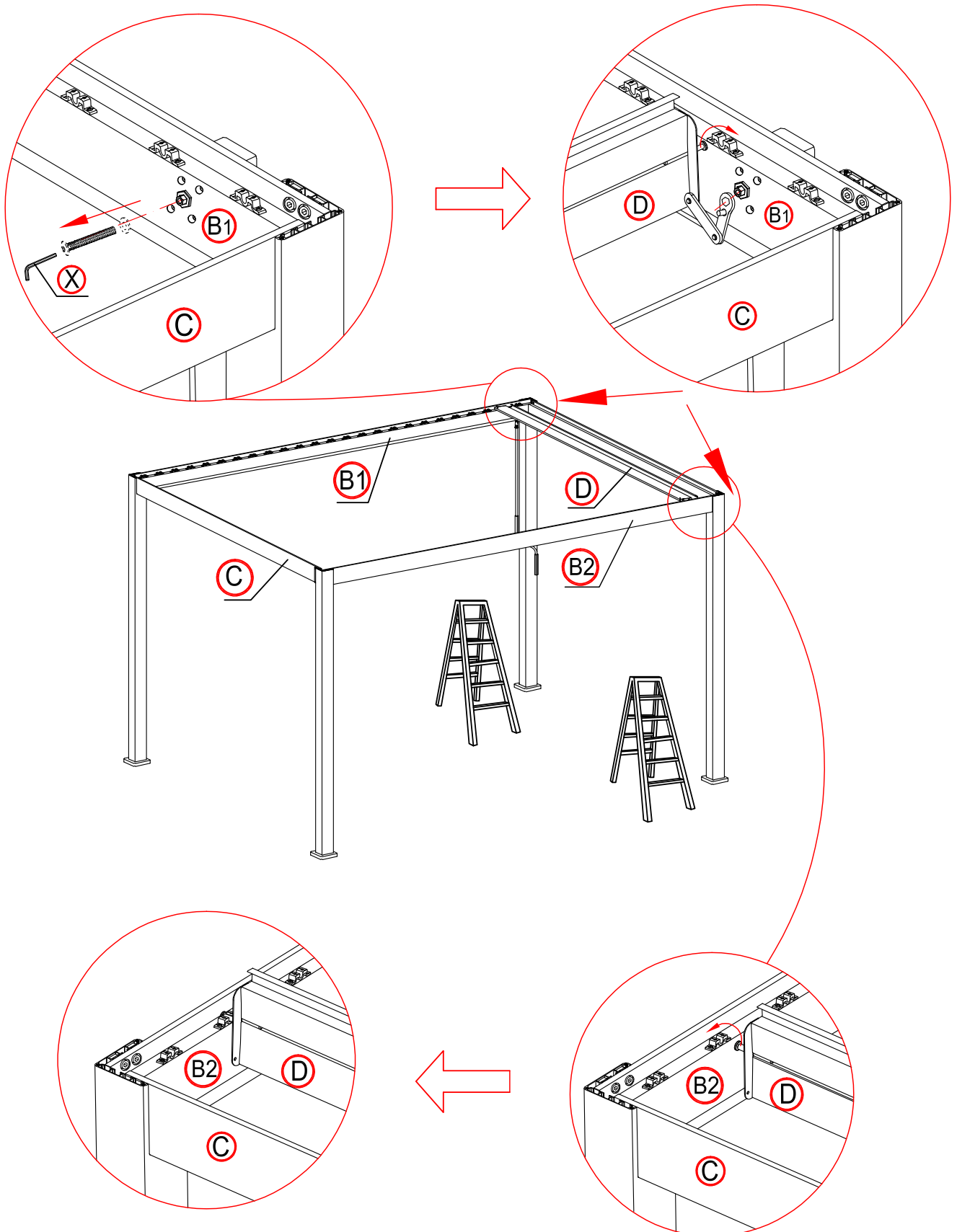

Attach the arm using the screw and nut that were removed in the previous step.

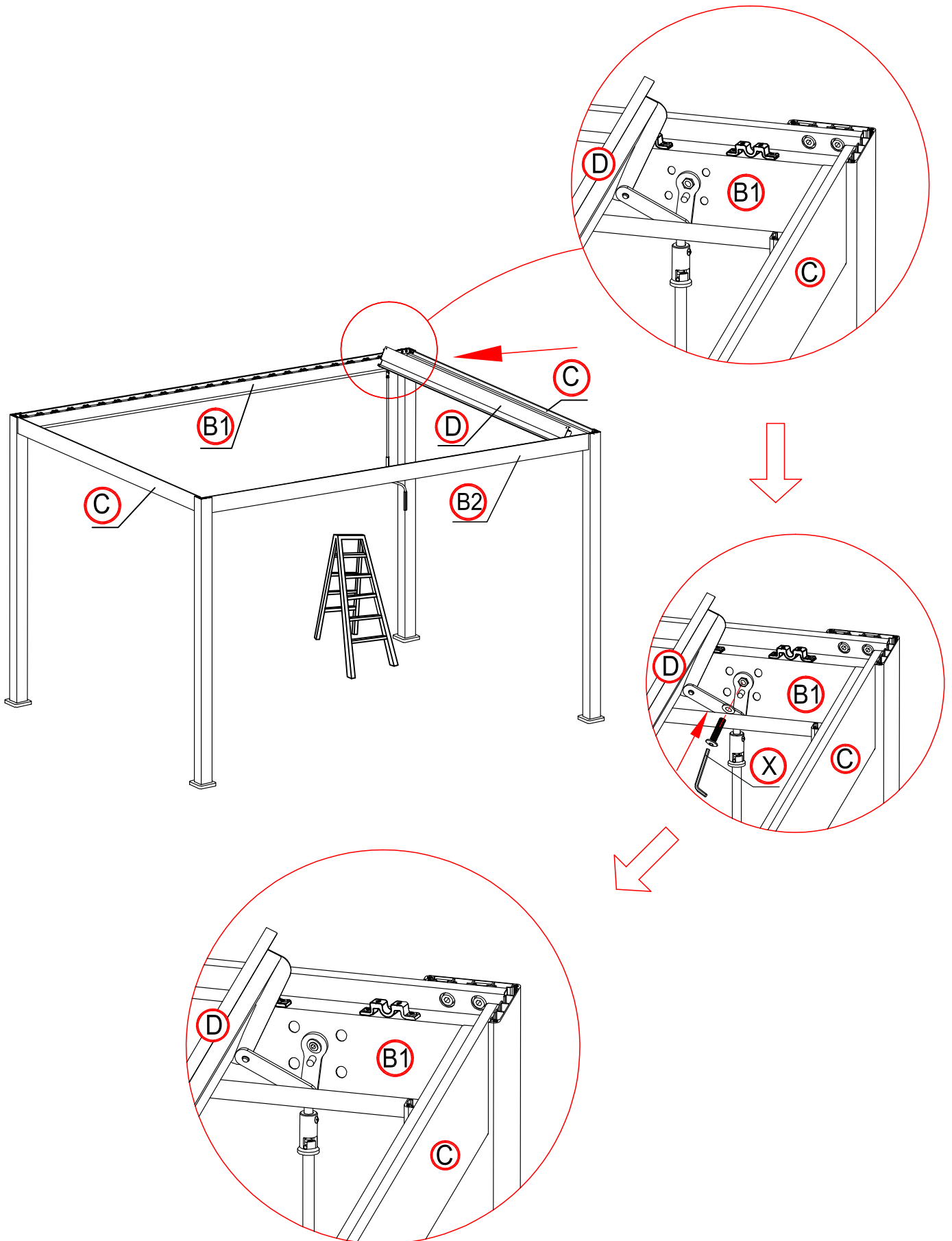

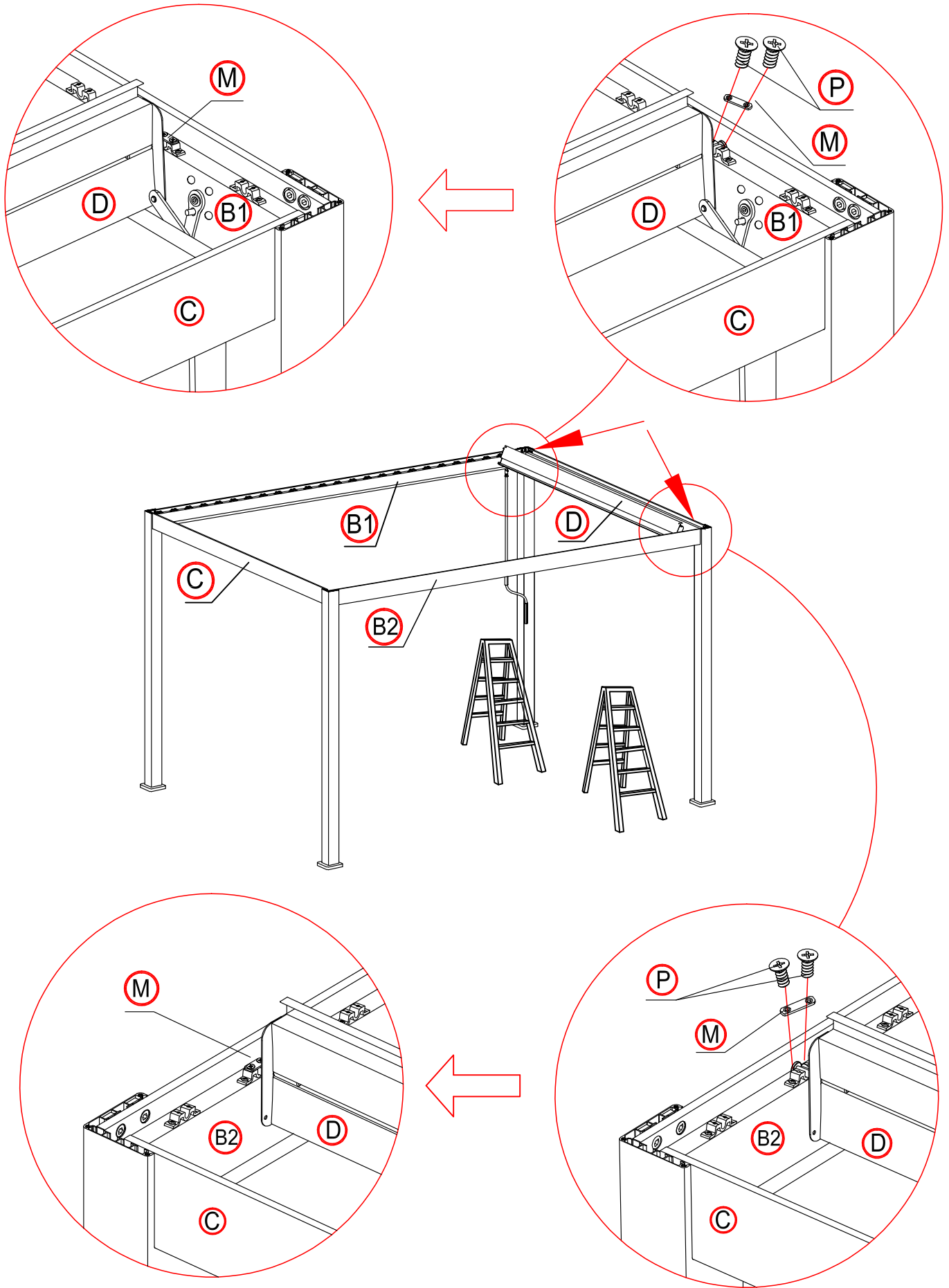

Ensure proper operation of the blade by positioning it vertically and horizontally with the H crank.

Assemble the remaining 24 blades on a clean, flat surface to avoid damaging the paint.
Start by screwing lightly and then tightening once all screws are in place.

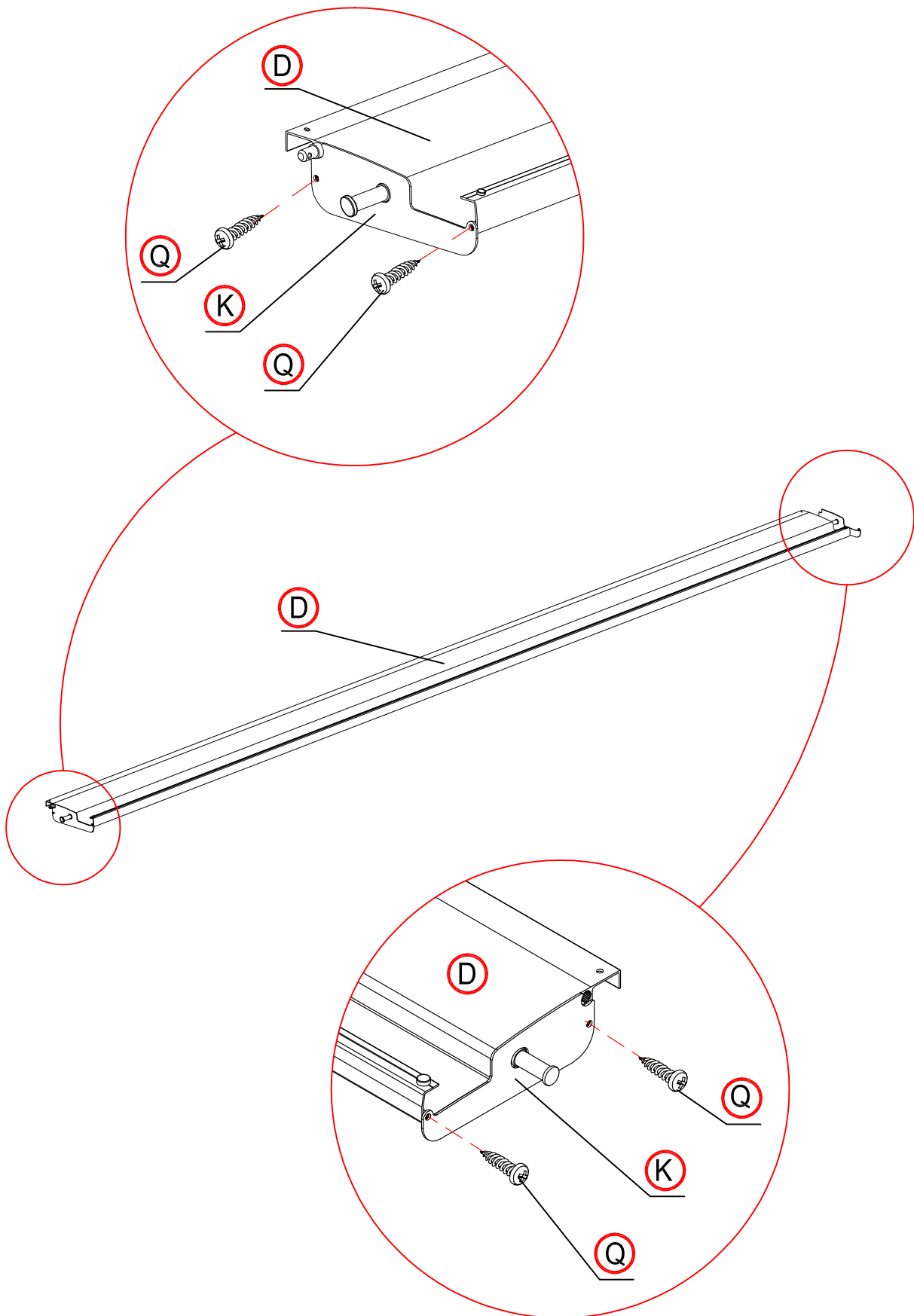

Attach the second blade to the first position and then manually position it horizontally. Also position the second blade horizontally using handle H. Check that the 2 blades are tightly sealed. They must naturally fit together.

If everything is in order, fix all the slats.

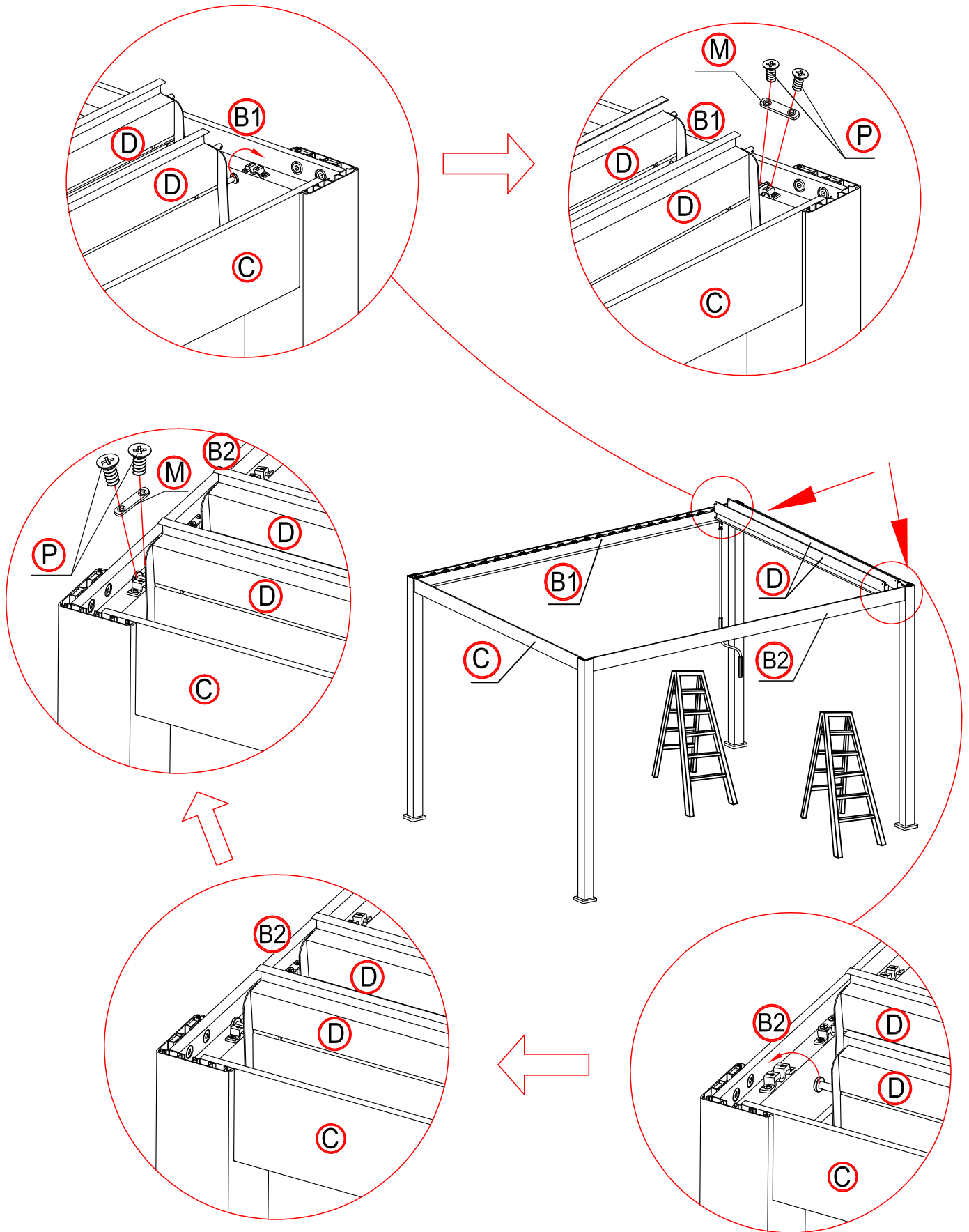

INSTALLING THE BLADES

Step 1 : Position the 2nd blade vertically with the handle H.

Step 2 : Take the part G and the pins S.

Step 3 : Position the 1st blade vertically and insert the part G (see diagram on next page) - insert the pins S to maintain the blades.

2 people are needed.

Repeat this operation to fix all the blades to the part G.

Step 4: Check that the mechanism is working properly once the installation is complete.

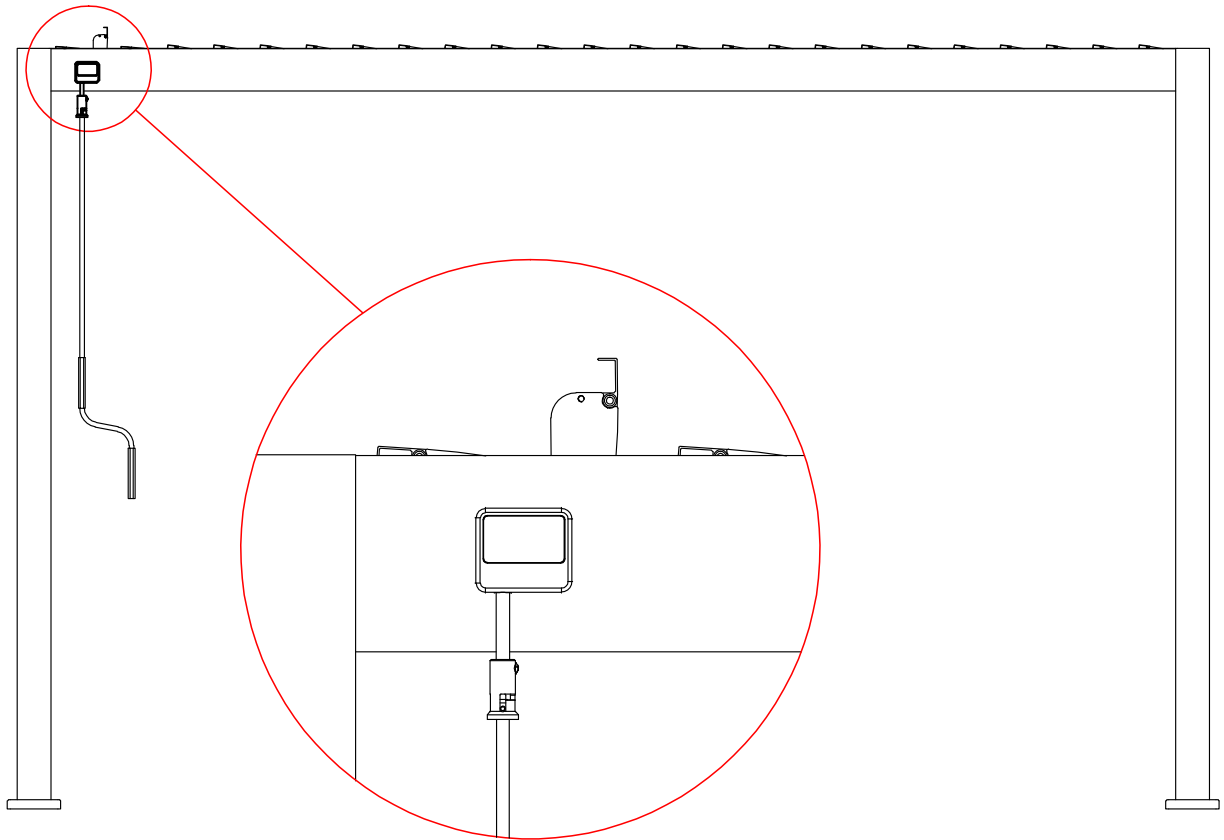

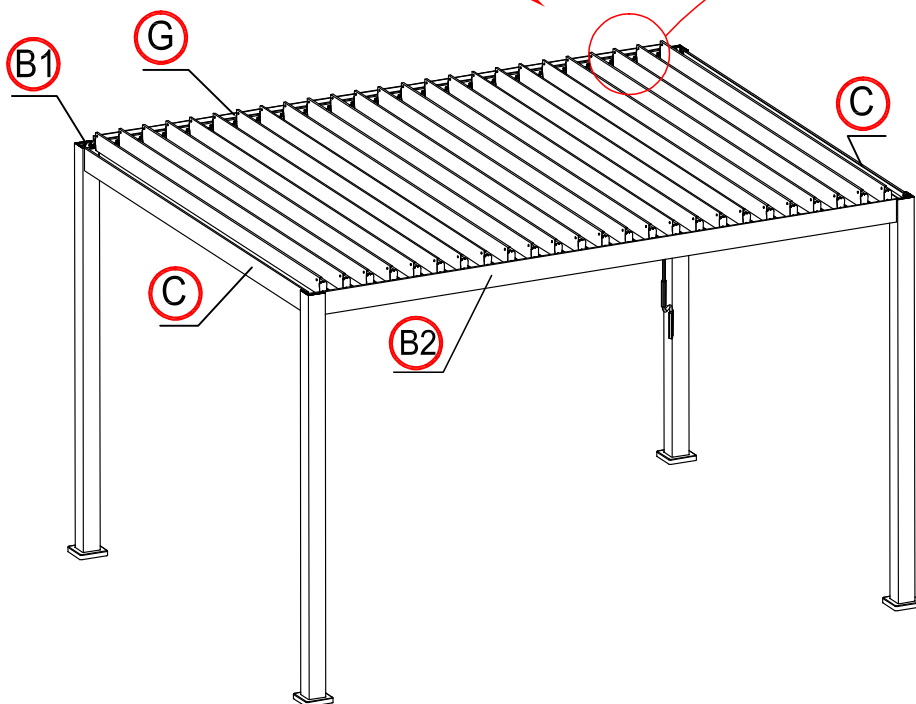
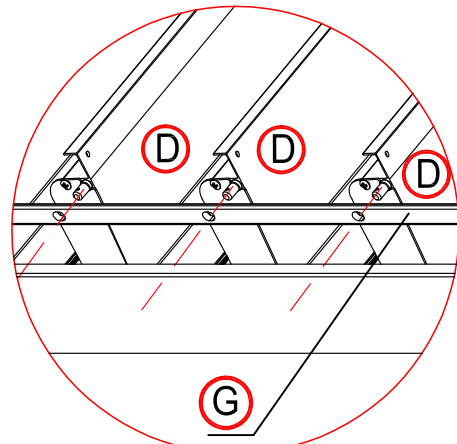
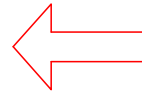
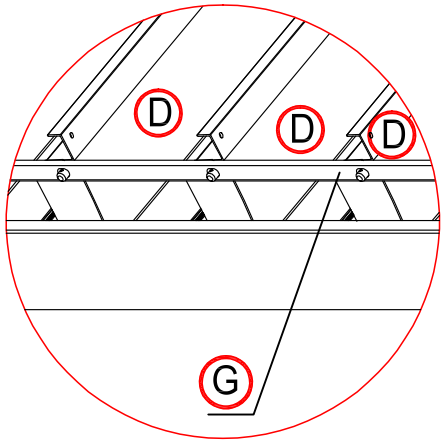
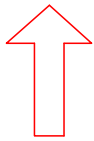
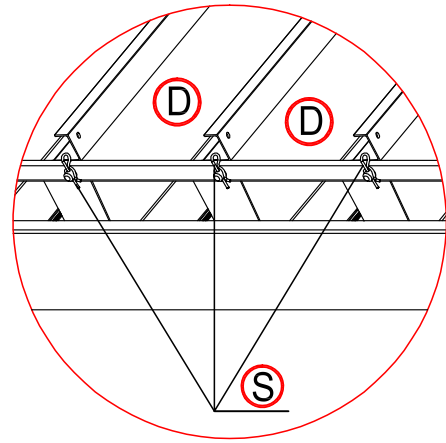
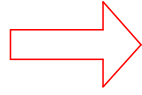
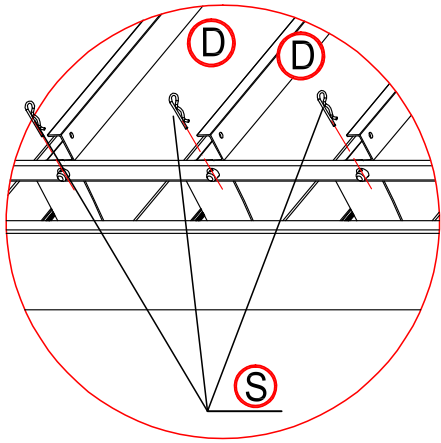

Attach the N piece to each corner of the pergola.

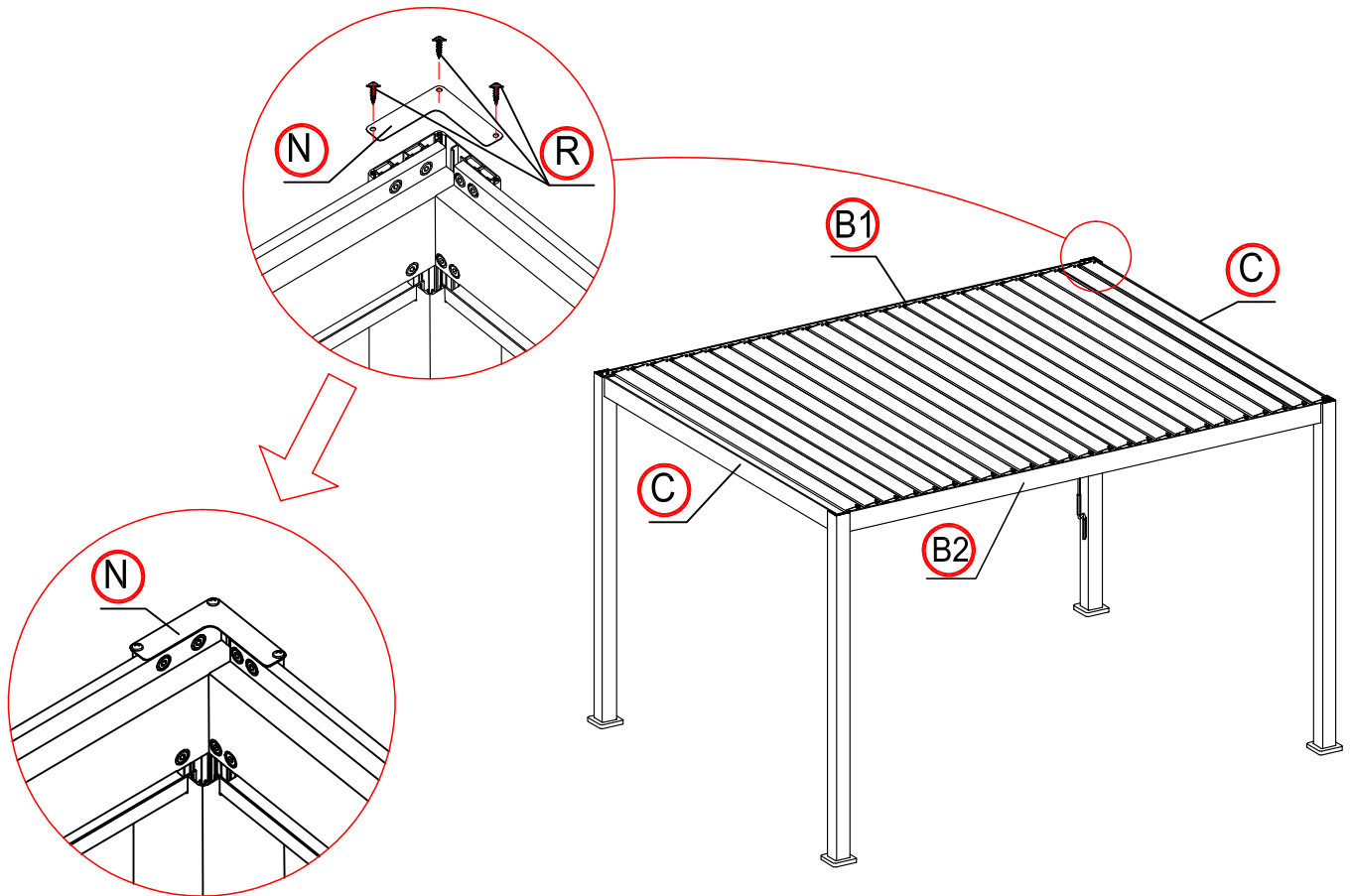

Secure the pergolas legs to the ground with the W pieces on a stable foundation, preferably concrete.

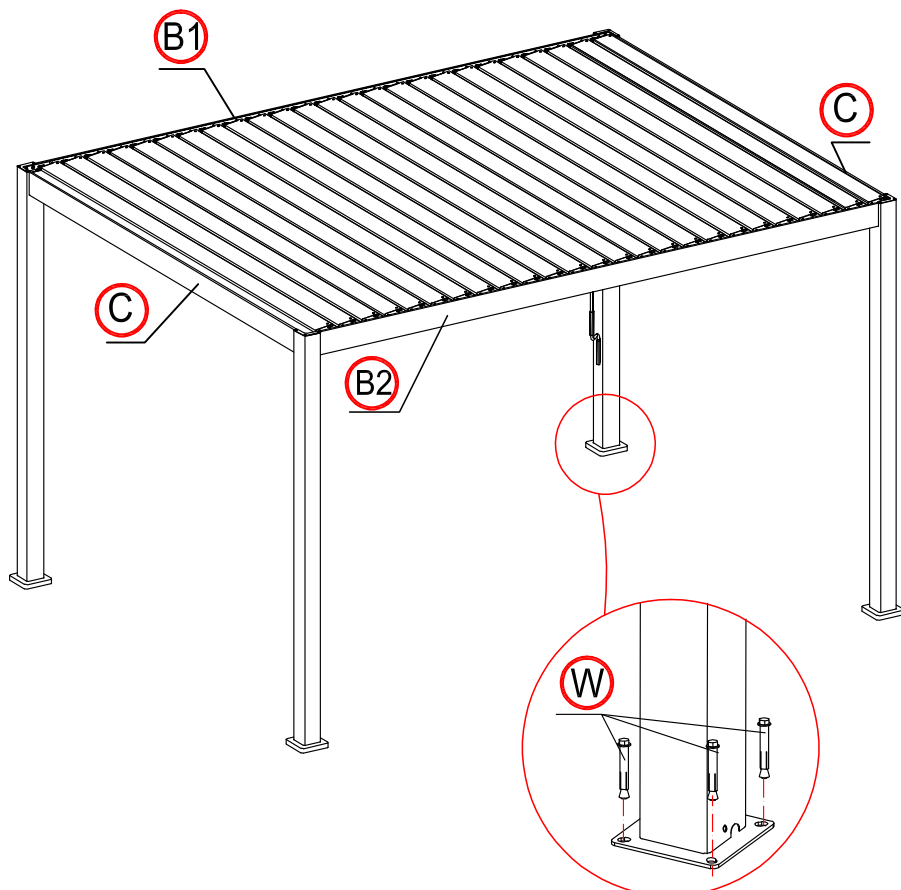

9. TECHNICAL QUESTIONS

For any further questions on our bioclimatical pergolas, do not hesitate to contact your local outlet store or to view our FAQ page on our website www.pergola-ombrea.com

Our instructions and assembly videos are available on www.pergola-ombrea.com/fr/notices

10. ACCESSORIES

4 METER SIDE

OMBRÉA® LATERAL BLINDS

3 METER SIDE

4M

Antracite : 15-709300

White : 15-709317

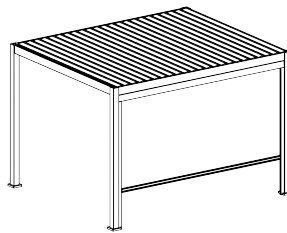

3M

Antracite: 15-709263

White: 15-709270

OMBRÉA® SIDE BLINDS WITH LOUVERS

1,3M

Antracite : 15-711532

White : 15-711549



1M

Antracite : 15-710399

White : 15-710405

11. SATISFACTION

We gladly welcome feedback from our clients in order to help us improve our services, don't hesitate to contact us by email : contact@pergola-ombrea.com

we would be grateful to receive pictures of your installation

We would like to thank you for your purchase and wish you happy days under your brand new Ombréa Pergola !