

Ombrea®

FR Pergola Bioclimatique Autoportante 4x6M

EN 4x6M freestanding louvered pergola / **ES** Pérgola Bioclimática Autoportante 4x6M

IT Pergola bioclimatica autoportante 4x6M

Anthracite/Dark Grey/Antracita/Antracite : 15-728783, **Blanc/White/Blanco/Bianco** : 15-728868, **Anthracite et Blanc/Dark gray & White/Antracita y blanco/Antracite e Bianco** : 15-728943

FR NOTICE DE MONTAGE p.2

EN INSTRUCTIONS MANUAL p.20

ES INSTRUCCIONES DE MONTAJE p.38

IT ISTRUZIONI DI MONTAGGIO p.56

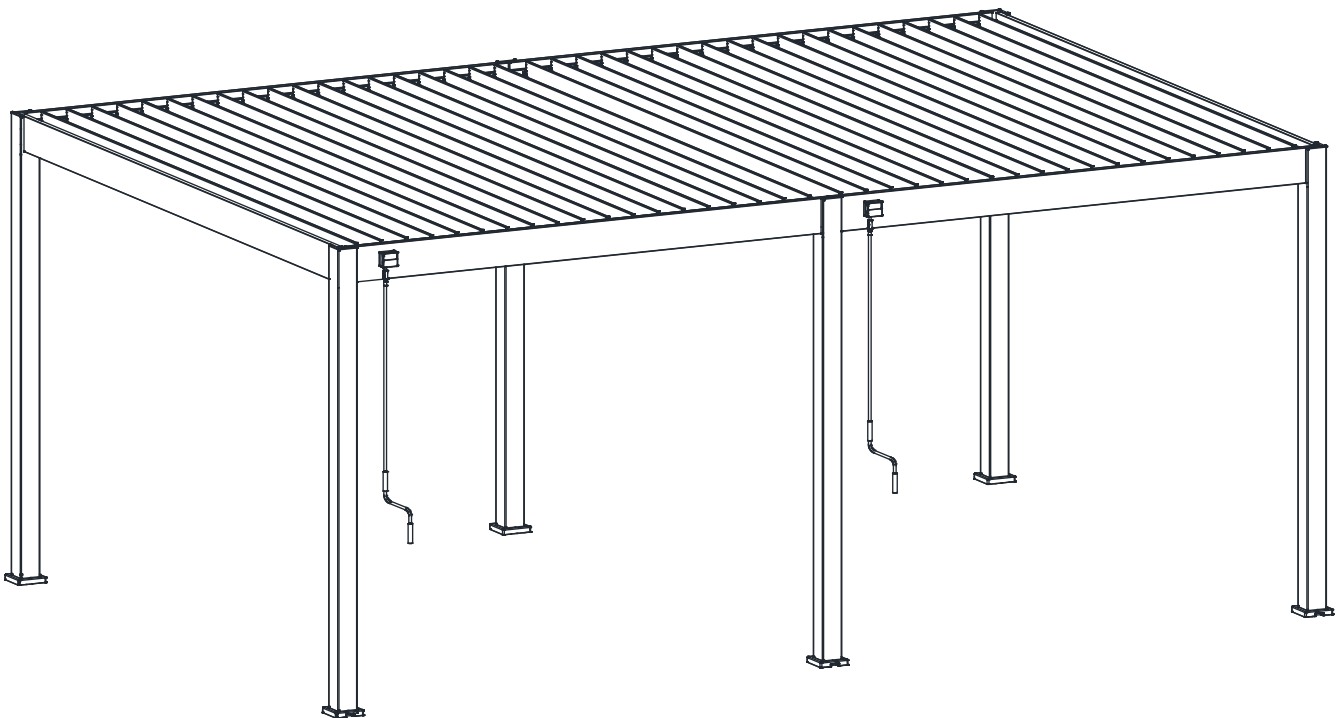

Pergola Bioclimatique Autoportante 4x6M

Anthracite : 15-728783 / **Blanc** : 15-728868 / **Anthracite et Blanc** : 15-728943

Notice à conserver pendant toute la durée de vie du produit.

Nous vous demandons de lire attentivement la notice avant de procéder au montage.

L'utilisateur sera responsable des dommages ou blessures causés par une utilisation non conforme.

1. PRÉCAUTIONS D'UTILISATION

Ce produit ne doit pas être utilisé en cas de fortes intempéries : orage, vent violent, grêle, neige. Nous garantissons la résistance de la pergola pour des vents jusqu'à 100 km/h et un poids de neige maximal de 50kg/m².

En cas de vents forts ou de neige, il est vivement recommandé de laisser les lames en position ouverte. En cas d'oubli, il faudra déneiger la pergola afin d'éviter une surcharge importante sur les lames.

Notre pergola peut supporter de fortes pluies, mais, nous ne pouvons pas vous garantir une étanchéité à 100%.

En cas d'épisodes climatiques exceptionnels, son étanchéité peut être compromise. Ne pas laisser des produits craignant l'humidité sous la pergola. Ne pas monter sur le toit ni sur la structure de la pergola.

2. CONSEILS DE MONTAGE

Selon l'emplacement et la surface, les constructions peuvent être soumises à des déclarations de travaux ou de demande de permis de construire. Veuillez vous rapprocher de votre mairie pour obtenir les informations utiles avant le montage.

Montage du produit :

- 2 à 3 personnes sont nécessaires
- Retirer les films de protection (durée estimée à 1h)
- Ne pas laisser les enfants jouer à proximité de la zone de montage
- Attention aux risques de pincement
- Ne jamais serrer complètement les vis avant d'avoir assemblé la partie concernée
- Toutes les étapes d'assemblage doivent être scrupuleusement respectées
- Contrôler les niveaux, les diagonales et l'aplomb
- Fixer la pergola qu'une fois assemblée

Aucune modification ne peut être apportée au produit. Les produits modifiés par l'utilisateur ne sont plus couverts par la garantie du fabricant.

Le lieu d'emplacement doit être choisi de manière appropriée. Il est recommandé d'éviter de monter votre pergola, par temps de pluie, face aux vents dominants et sous un arbre.

La pergola doit être montée sur une fondation adéquate stable et nivelée, il est recommandé de l'installer sur une dalle en béton ou sur des plots en béton 25x25 cm au niveau de chaque poteau. Nous vous demandons d'ancrer correctement la pergola au sol à l'aide des pièces TO.

Si vous souhaitez positionner votre pergola près de votre maison ou d'un bâtiment, nous vous demandons de vérifier la présence de gouttières pour l'écoulement des eaux. La pergola Ombréa® ne pourra pas supporter et garantir une étanchéité parfaite si les eaux de pluie de votre habitation s'y déversent.

En cas de non-respect des recommandations de montage, la garantie ne pourra être appliquée.

3. ENTRETIEN DE LA PERGOLA

Un entretien régulier est nécessaire pour assurer sa longévité et son aspect esthétique.

Nous recommandons de :

- Laver votre pergola 1 à 2 fois par an à l'eau douce à l'aide d'une éponge ou d'un chiffon. Ne pas utiliser de détergent ou matériau abrasif.
- Vérifier le serrage des vis régulièrement (au moins 1 fois par an).
- Huiler les pièces de quincaillerie régulièrement (au moins 1 fois par an).
- Veiller à ce que rien ne gêne l'écoulement des eaux dans les gouttières (feuilles, branches...).
- Enlever l'eau qui pourrait stagner autour des pieds de la pergola (soulever les protections).

4. GARANTIE

Ombréa® garantit la disponibilité des pièces détachées pendant 2 ou 5 ans (suivant le produit). Elle ne s'applique que si les consignes de stockage, de montage, d'utilisation, d'entretien sont respectées.

La garantie ne couvre pas :

- L'usure normale inhérente aux produits.
- La perte ou la casse de toutes pièces lors du déballage ou de l'installation.
- Le manque de soins raisonnable, la négligence, le vandalisme, les impacts avec des objets étrangers, l'usage de la force, le contact avec des abrasifs, l'esthétique, le démontage, la reconstruction ou relocalisation.
- Les forces majeures : grêle, vents forts, tempêtes, neige, inondations, foudre...
- Produit modifié par l'utilisateur

La garantie comporte seulement le remplacement de la pièce détachée ou du produit fourni, à l'exclusion de tout frais et indemnités de quelque nature que ce soit.

Toute demande de garantie doit être formulée au point de vente (magasin ou site internet) dans lequel vous avez acheté votre produit.



5. LISTE DES PIÈCES (PAR CARTON)

Avant de procéder au montage de votre pergola bioclimatique, il est nécessaire de vérifier que toutes les pièces soient présentes et ne soient pas endommagées.

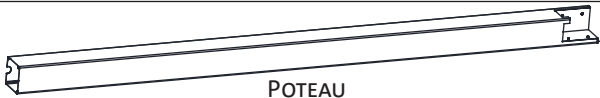

Toute pièce manquante doit être signalée dans les 10 jours suivant l'achat. Vous pouvez passer par votre revendeur ou faire la demande directement sur notre site sav.comintes.com.

Ne pas jeter l'emballage sans s'assurer du bon fonctionnement de la pergola.

CARTON 1/6 (POTEAUX ET QUINCAILLERIE)

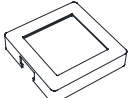
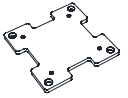
Référence	Schéma	Quantité
AO	 POTEAU	4
AO-1	 POTEAU CENTRAL	2

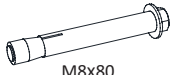

Référence	Schéma	Quantité
IO	 CACHE PLATINE	6
JO	 PLATINE DE FIXATION	6



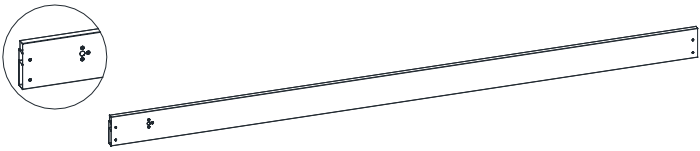
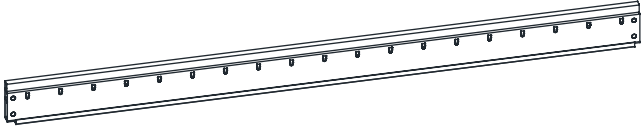
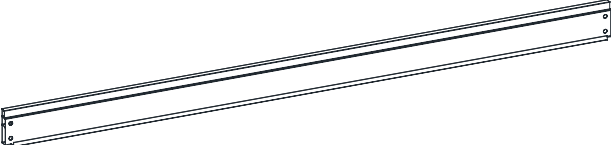



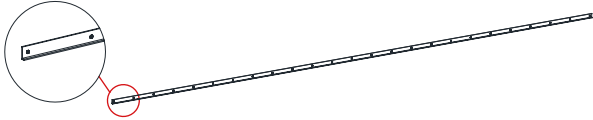



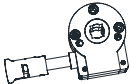





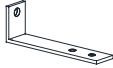

Référence	Schéma	Quantité
TO	 M8x80 CHEVILLE BÉTON	24
XO-1	 6x35 BOULON 6X35	24

CARTON 2/6 (POUTRES ET QUINCAILLERIE)

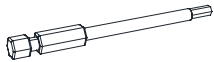
Référence	Schéma	Quantité
BO-1	 POUTRE PRINCIPALE	2
BO-2	 POUTRE ARRIÈRE	2
CO	 POUTRE LATÉRALE	2







CARTON 2/6 (POUTRES ET QUINCAILLERIE)

Référence	Schéma	Quantité
EO	 POUTRE CENTRALE	1
FO	 BARRE DE CONNEXION	2
HO	 MANIVELLE	2

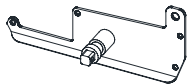
Référence	Schéma	Quantité	Référence	Schéma	Quantité
NO	 GEARBOX	2	XO	 6x40 BOULON 6x40	74
OO	 BOITIER	2	XO-2	 6x20 BOULON 6x20	38
PO	 CYLINDRE	2	YO	 6x45 BOULON 6x45	6
QO	 VIS DE FIXATION POUTRE	24	ZO-1	 CLÉ ALLEN 4mm	1
QO-1	 PATTE DE RACCORDEMENT	2	ZO-2	 EMBOUT VISSEUSE 4mm	1
RO	 CAPUCHON DE FINITION	24	ZO-3	 CLÉ ALLEN 6mm	1
SO	 CALE DEMI-LUNE	76	ZO-4	 EMBOUT VISSEUSE 6mm	1
UO	 ÉCROU	114	ZO-5	 CLÉ PLATE 10mm	1
UO-1	 ÉCROU EN PLASTIQUE	76	ZO-6	 EMBOUT VISSEUSE T20	1
VO	 RONDELLE	114	ZO-7	 EMBOUT VISSEUSE	1

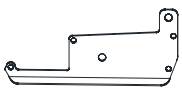
CARTON 3/6 (LAMES ET QUINCALLERIE)

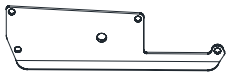
Référence	Schéma	Quantité
GO	 LAME	8

Référence	Schéma	Quantité	Référence	Schéma	Quantité
KO	 CACHE LAME PRINCIPAL	2	MO	 ERGOT	74
LO	 CACHE LAME A	36	WO	 4x16 VIS 4X16	308
LO-1	 CACHE LAME B	38	WO-1	 5x19 VIS AUTO-PERFORANTE 5X19	2

CARTON 4/6, 5/6 ET 6/6 (LAMES)

Référence	Schéma	Quantité
GO	 LAME	10

Les pièces en aluminium sont les suivantes : AO, AO-1, BO-1, BO-2, CO, FO, GO, IO, KO, LO et LO-1.

La visserie, ainsi que les autres pièces sont soit en Inox, en acier galvanisé, en plastique ou en nylon.

Pour plus de renseignements, référez-vous aux caractéristiques techniques du produit et consultez notre page FAQ sur le site www.pergola-ombrea.com ou rapprochez-vous de votre revendeur.

6. MATÉRIEL (NON FOURNI) NÉCESSAIRE POUR LE MONTAGE



Lunettes et gants de protection



2 escabeaux



Perforateur + foret béton 12mm



Perceuse visseuse

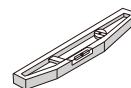

Niveau à bulle



Cutter



Casque de sécurité

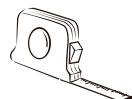

Mètre ruban

7. CONTACT

Soucieux de nous améliorer, n'hésitez pas à nous faire part de vos remarques et suggestions à l'adresse suivante : contact@pergola-ombrea.com

Nous serions ravis de recevoir les belles photos de votre installation.

L'équipe Ombréa vous remercie pour votre achat et vous souhaite des jours heureux sous votre pergola !

8. PLAN DE MONTAGE (DIMENSIONS EN MM)

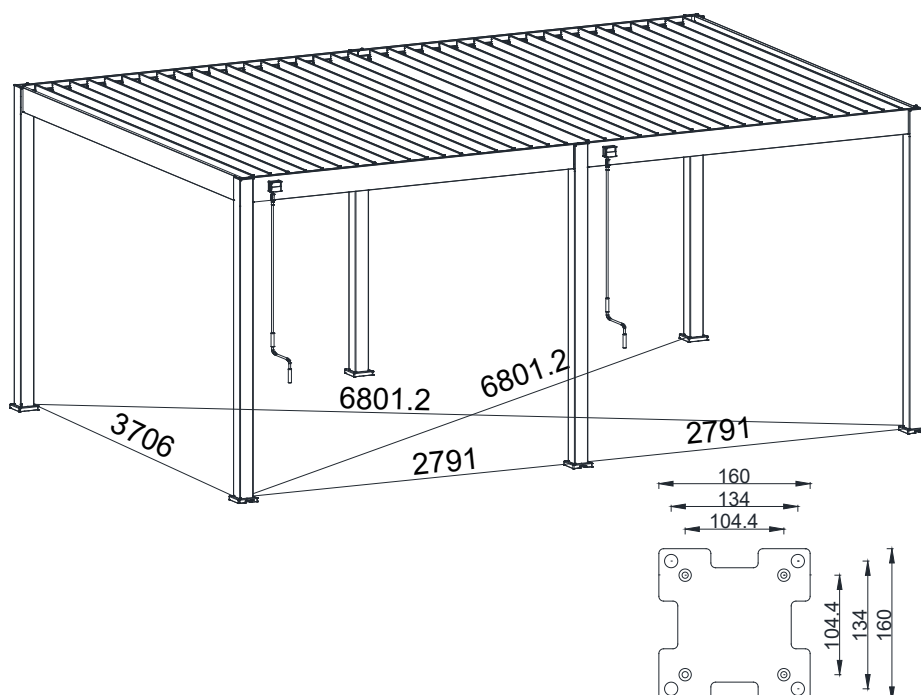
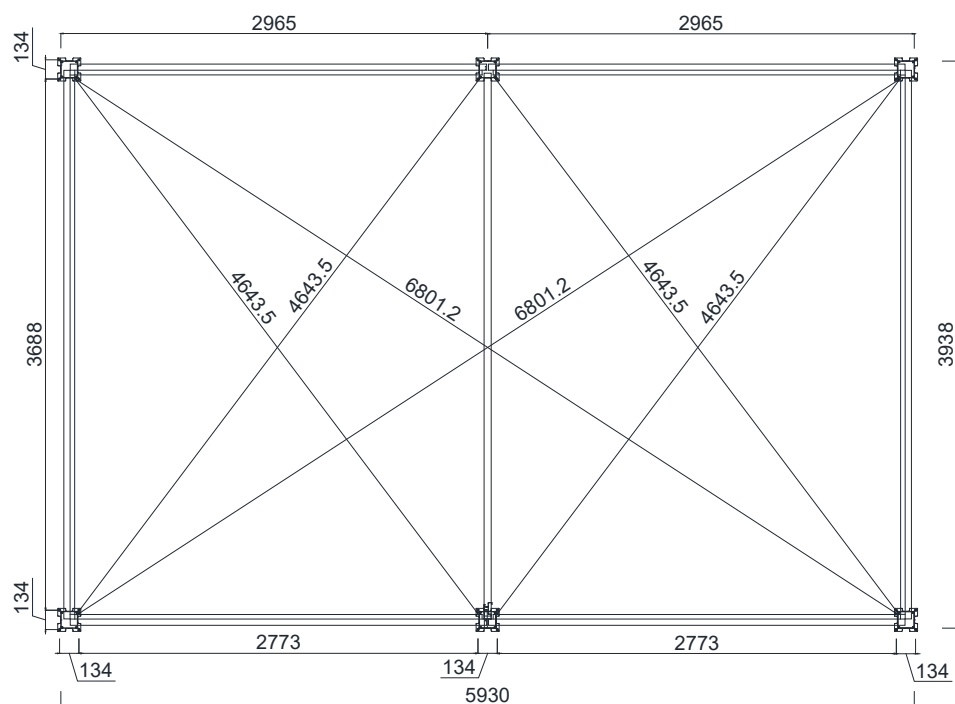

9. ÉTAPES DE MONTAGE

Afin d'éviter tout endommagement de votre pergola durant le processus de montage, nous vous recommandons de les assembler sur une table, sur des tréteaux ou d'aménager une surface plate et propre.

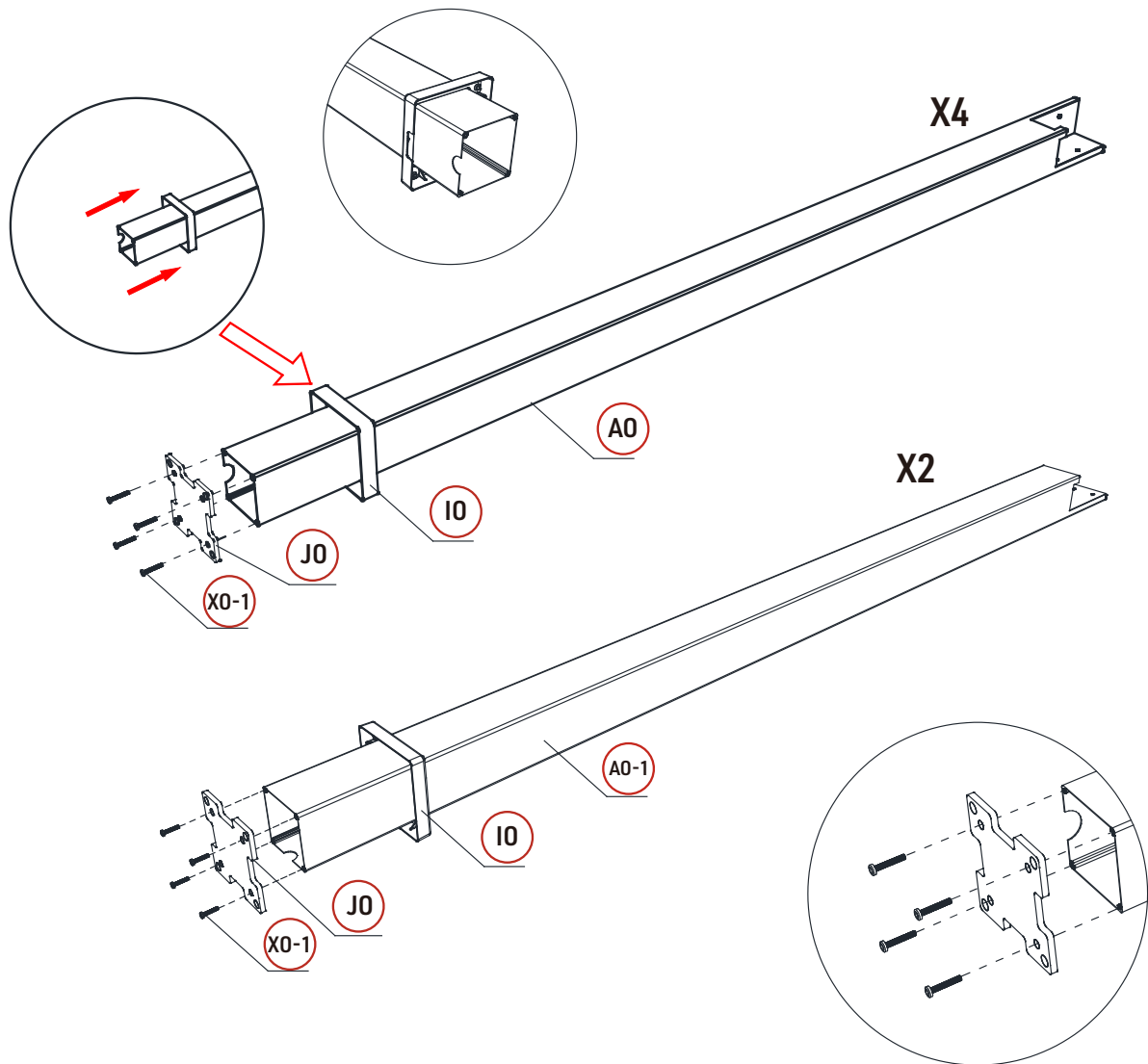

Glisser les caches **IO** sur les poteaux **AO** et **AO-1**, en positionnant l'ouverture dans le même sens que l'ouverture située sur le poteau en forme de demi-lune.

Puis, fixer la platine **JO** avec les vis **XO-1** à l'aide d'une visseuse. Commencer par serrer légèrement, puis complètement une fois que toutes les vis sont positionnées.

Positionner et fixer la poutre **CO** sur les poteaux **AO** avec les vis **QO** de chaque côté, à l'aide d'une visseuse et de l'embout **ZO-4** ou de la clé Allen **ZO-3**.

Répéter l'opération une seconde fois avec les mêmes pièces restantes

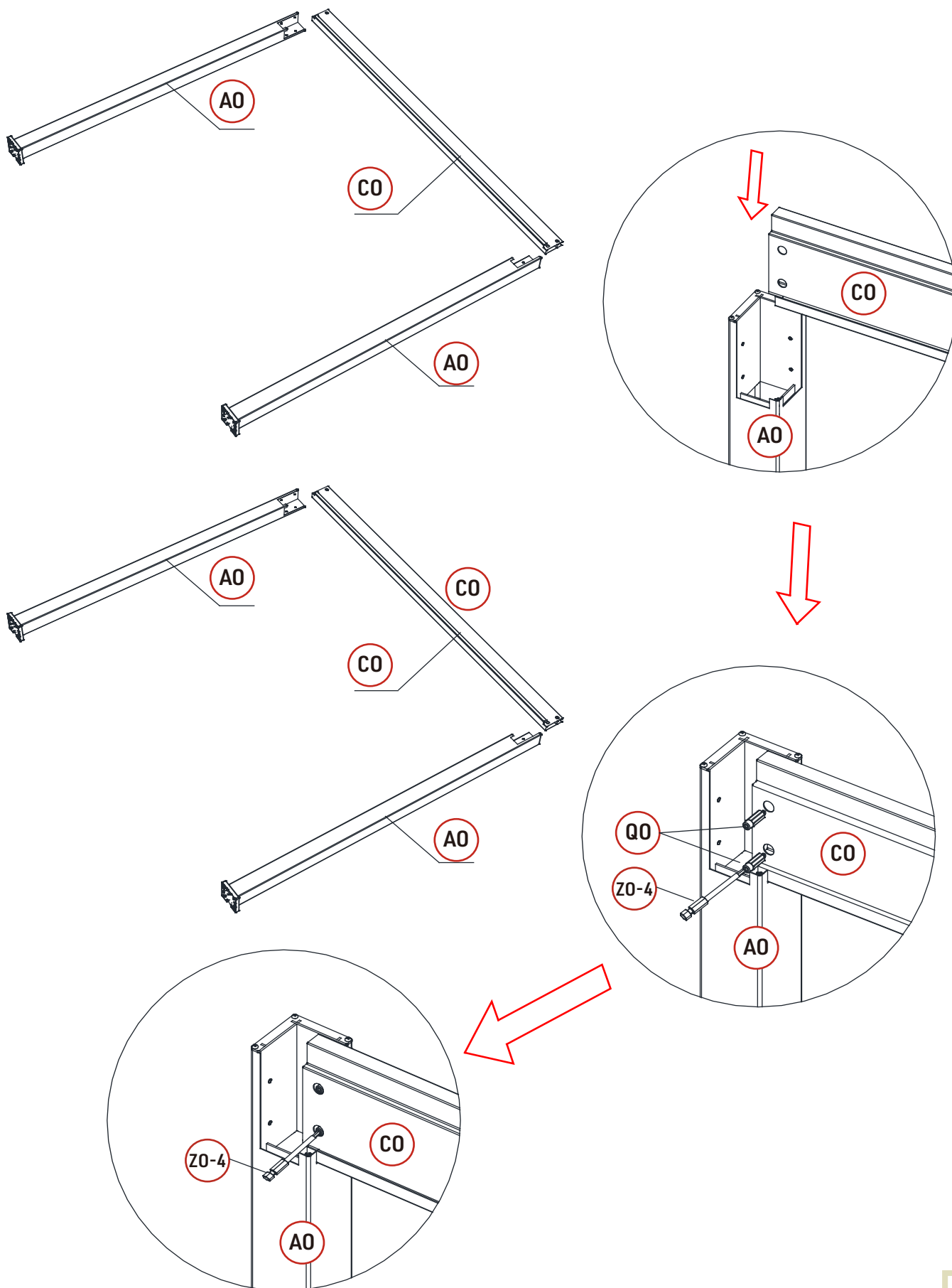

À l'aide de 2/3 personnes (une qui maintient la structure, une en charge de l'installation et une en charge d'assistant à l'installation), ajouter les poutres **BO-1** et **BO-2** sur les poteaux **AO** et **AO-1** comme indiqué sur le schéma. Puis, fixer avec les vis **QO** à l'aide d'une visseuse et de l'embout **ZO-4** ou de la clé Allen **ZO-3**.

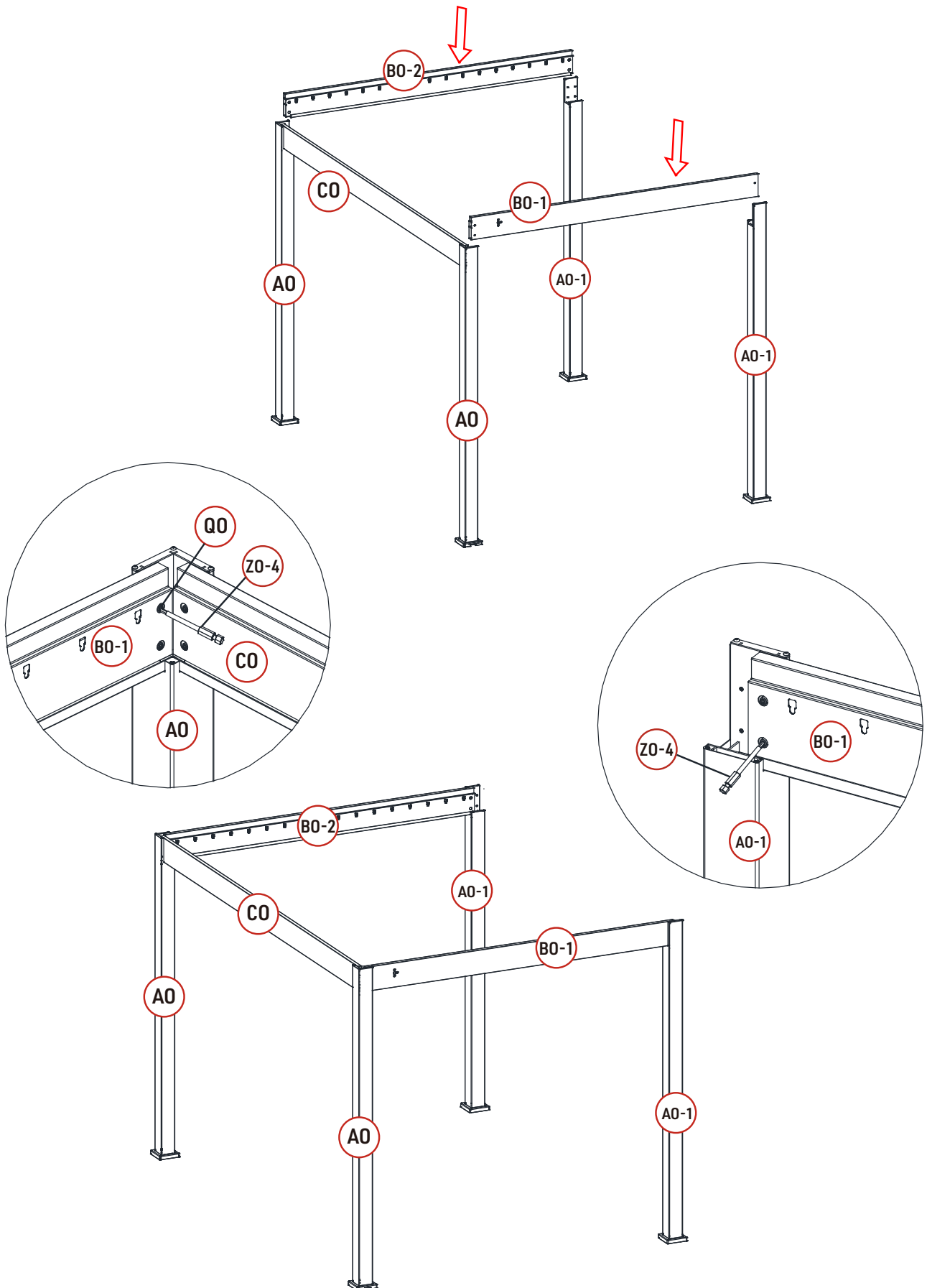

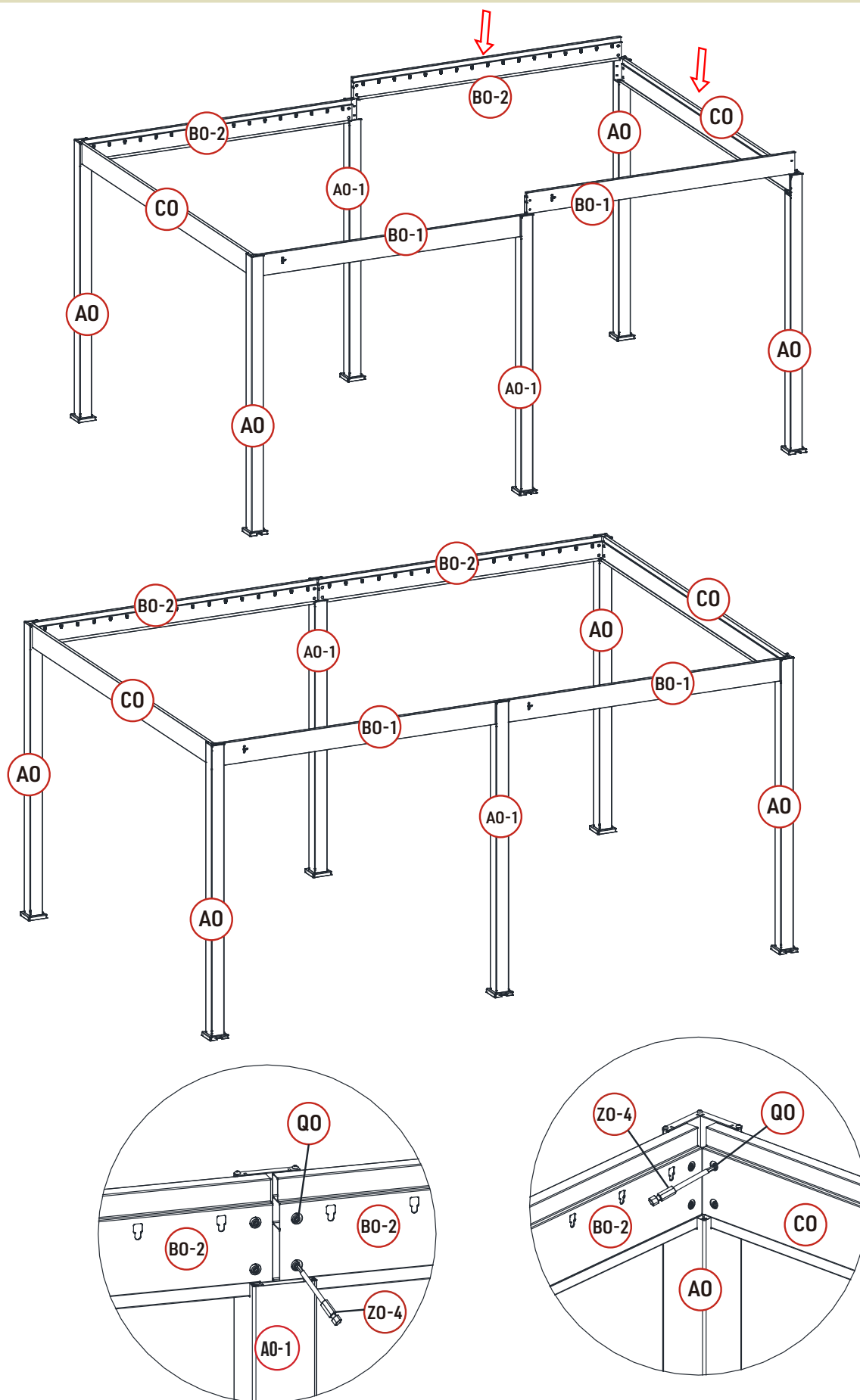

Fermer la structure comme indiqué sur le schéma, en formant la seconde partie de la pergola avec les poutres **BO-1** et **BO-2**. Les fixer d'un côté aux poteaux **AO** et de l'autre au poteaux **AO-1** avec les vis **QO**, à l'aide d'une visseuse et de l'embout **ZO-4** ou de la clé Allen **ZO-3**.

Fixer les pattes de raccordement **QO-1** dans le bon sens aux extrémités de la poutre centrale **EO**, avec les vis **WO**.

Positionner et caler la poutre **EO** au centre du cadre sur les poteaux **AO-1**, puis à l'aide d'une visseuse et de l'embout **ZO-7**, fixer le raccord **QO-1** sur les poutres **BO-1** et **BO-2** avec les vis auto-perforantes **WO-1**, comme indiqué sur le schéma.

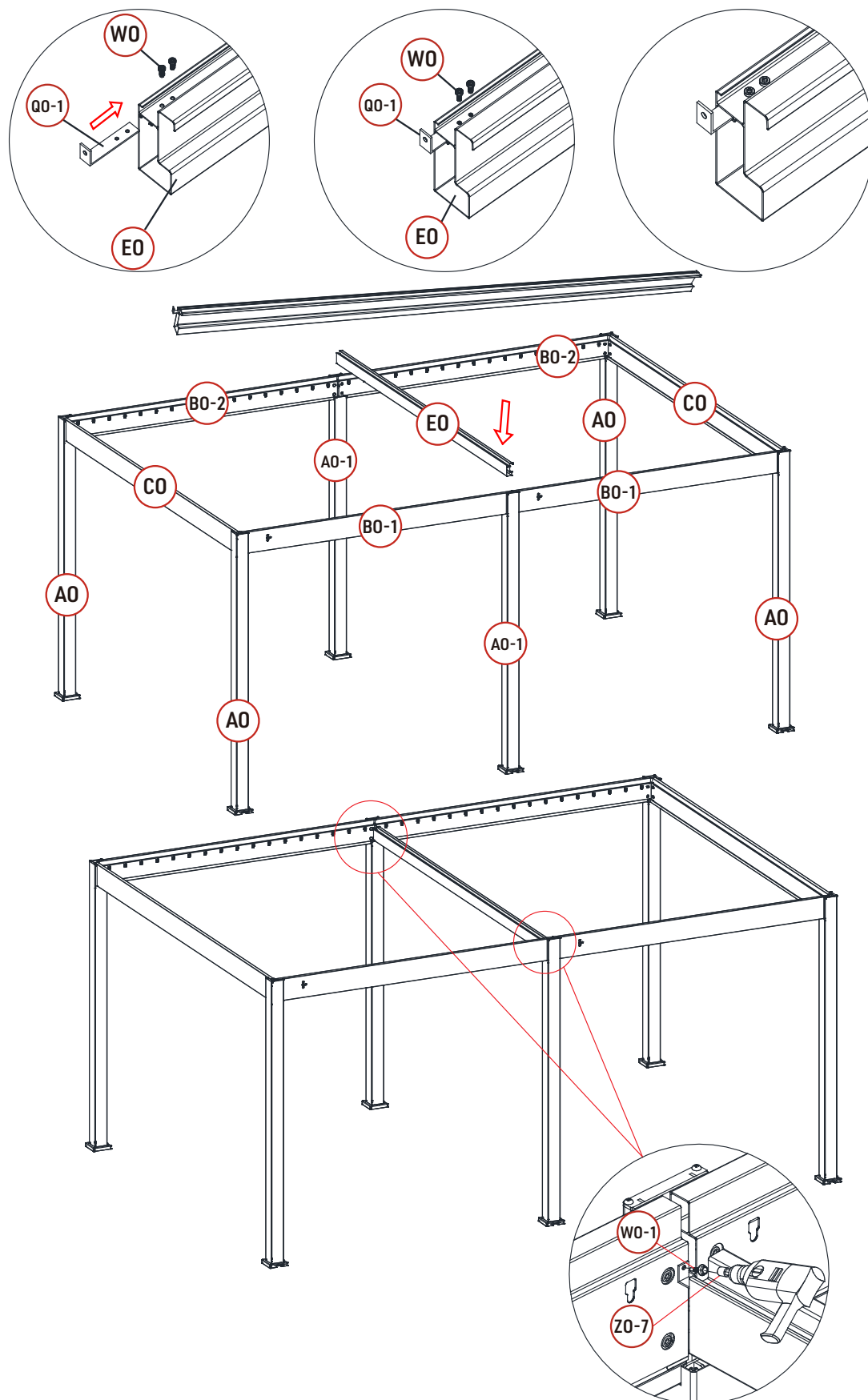

Constituer et fixer l'ergot correspondant à l'ensemble des pièces **XO**, **MO** et **UO** dans les caches lames **LO** et **LO-1**. S'assurer que l'ergot est bien installé dans le bon sens pour la pièce **LO** et pour la pièce **LO-1**, comme indiqué sur le schéma.

Utiliser une visseuse et l'embout **ZO-2** pour faciliter l'insertion du boulon **XO** dans l'écrou **UO**. Pour ne pas être blessé et pour que l'opération ne soit pas trop difficile, nous recommandons de maintenir l'écrou avec la clé **ZO-5** durant cette manipulation.

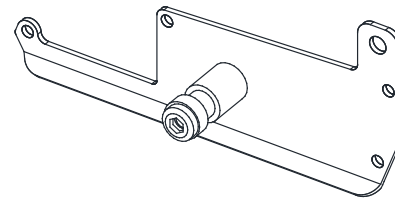
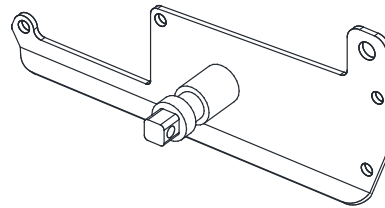
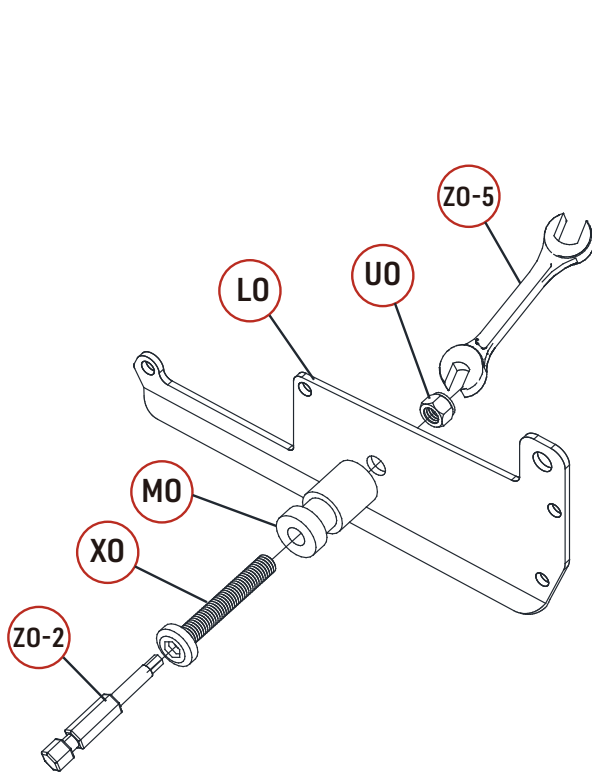

X36

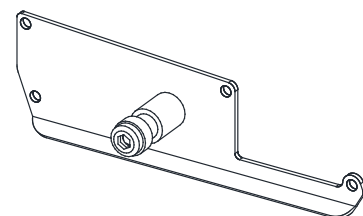
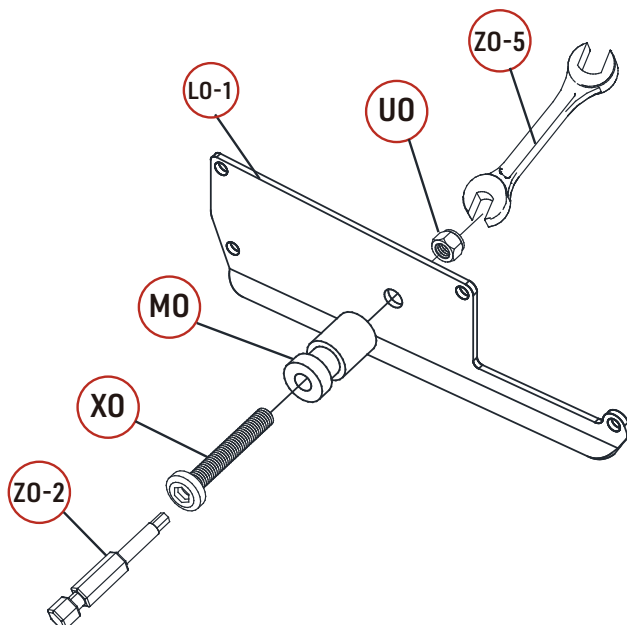

X38

Positionner la lame principale **GO** dans le bon sens comme indiqué sur le schéma, puis fixer le cache lame principal **KO** à droite de la lame et **LO-1** à gauche, avec les vis **WO** à l'aide d'une visseuse et de l'embout T20 **ZO-6**.

X2

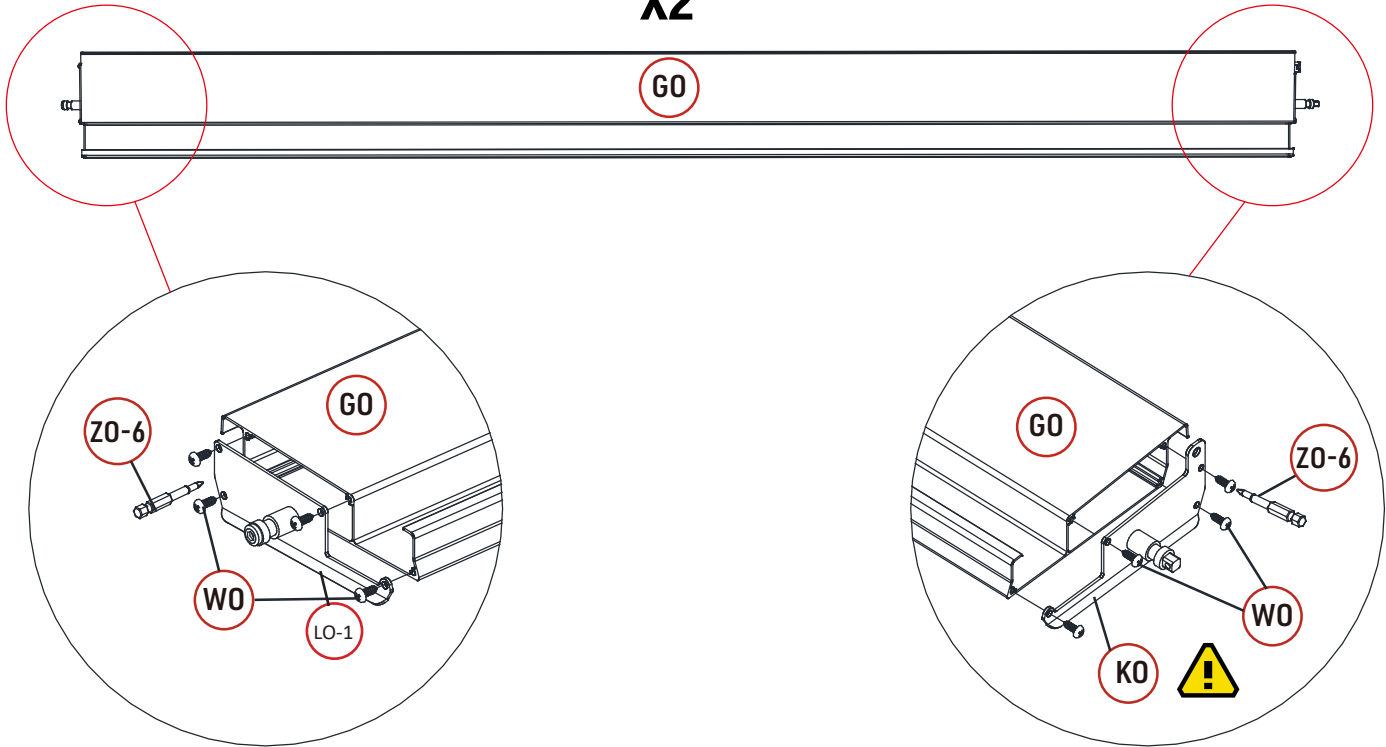

Répéter la même opération avec les autres lames **GO**, en fixant les caches-lame **LO-1** à gauche et **LO** à droite.

X36

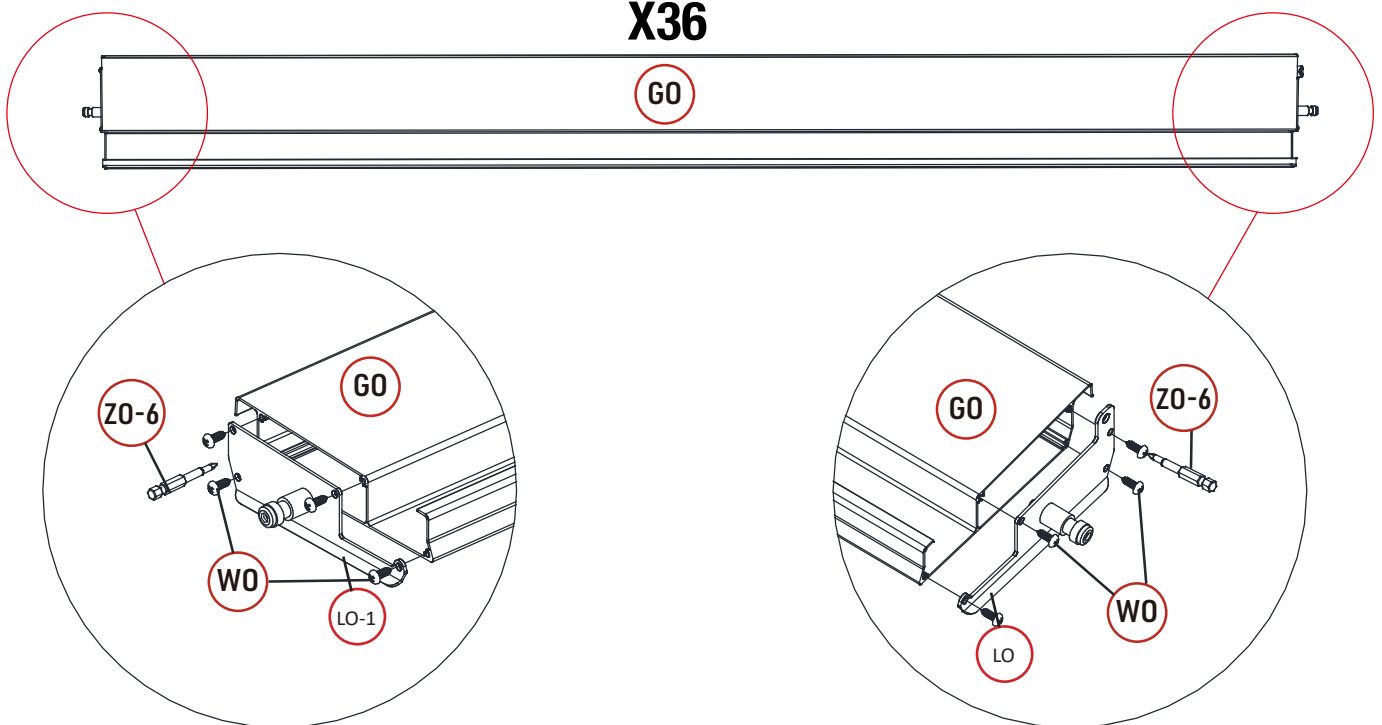

Installer la lame principale en seconde position de l'endroit prévu à cet effet sur la pergola, en commençant du côté de la manivelle pour former le toit.

Puis, répéter l'opération pour la seconde partie de la pergola.

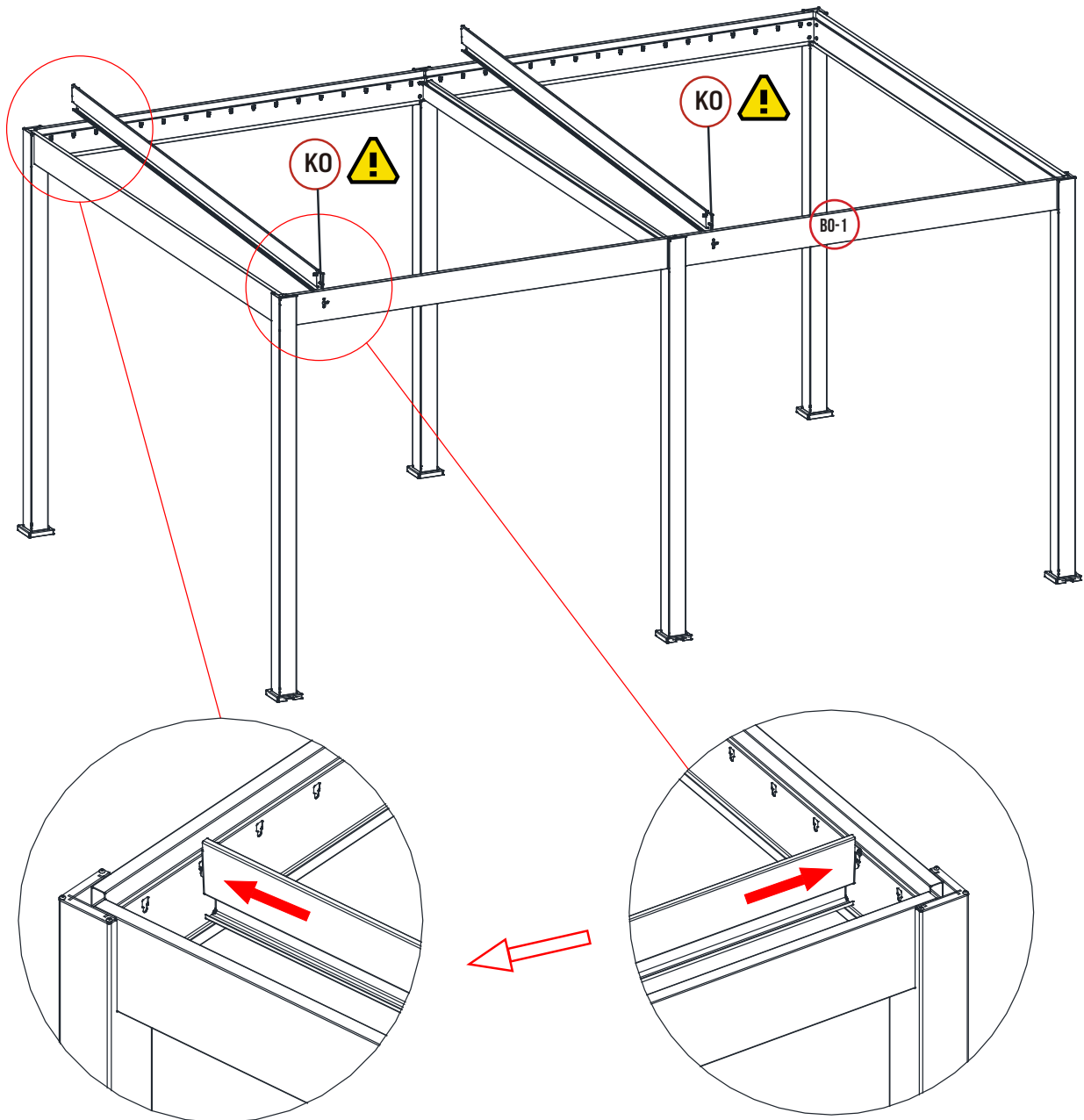

Insérer le cylindre **PO** au travers de la poutre comme indiqué sur le schéma, puis pousser jusqu'à emboîtement avec l'ergot de la lame principale **KO**.

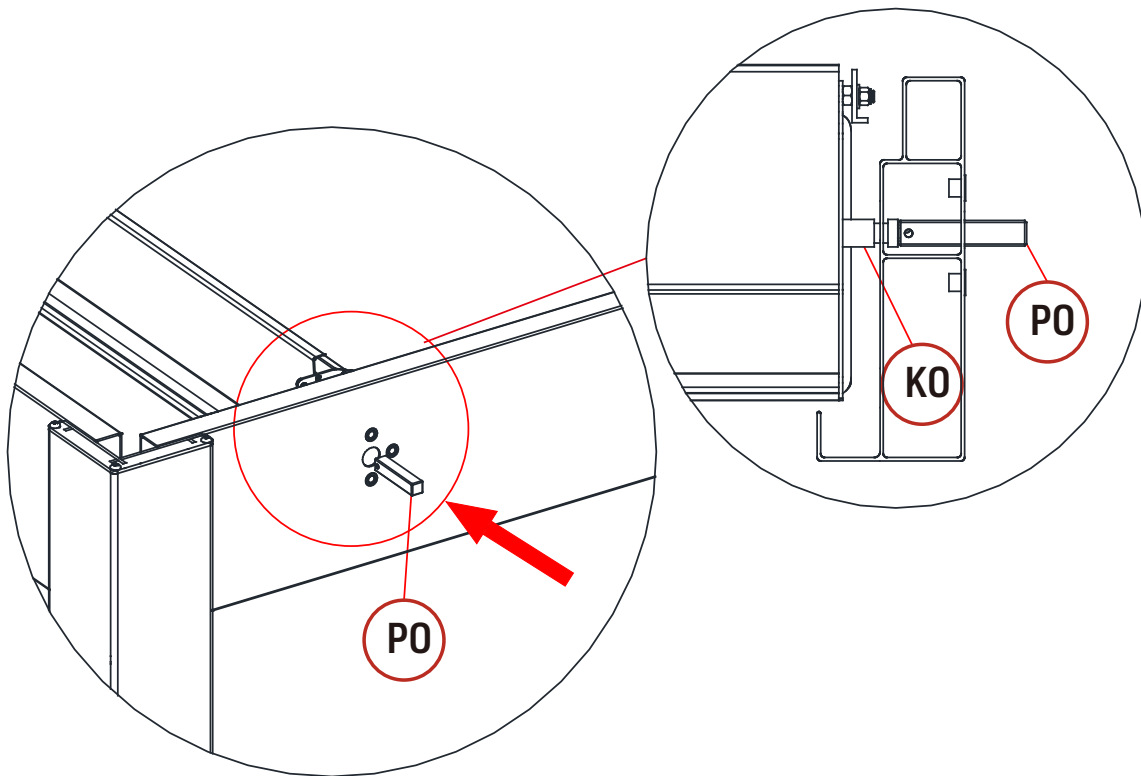

Associer et visser la première partie du boîtier **OO** avec la gearbox **NO** sur la poutre principale **BO-1**, avec les 3 boulons **YO**, à l'aide de la clé Allen **ZO-3** ou d'une visseuse et de l'embout **ZO-4**.

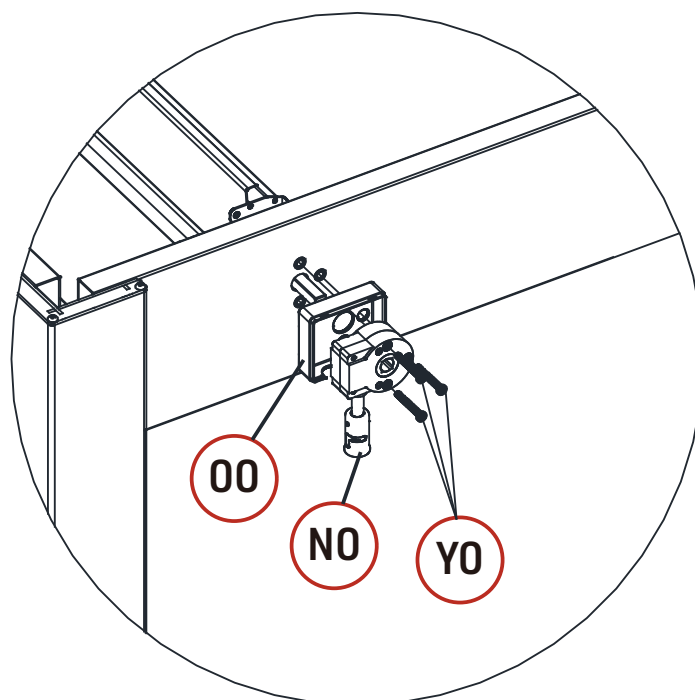

Ensuite, répéter l'opération pour la seconde moitié de la pergola.

S'assurer du bon fonctionnement du mécanisme manuel, en faisant une rotation de la lame vers la droite, puis vers la gauche à l'aide de la manivelle **HO**.

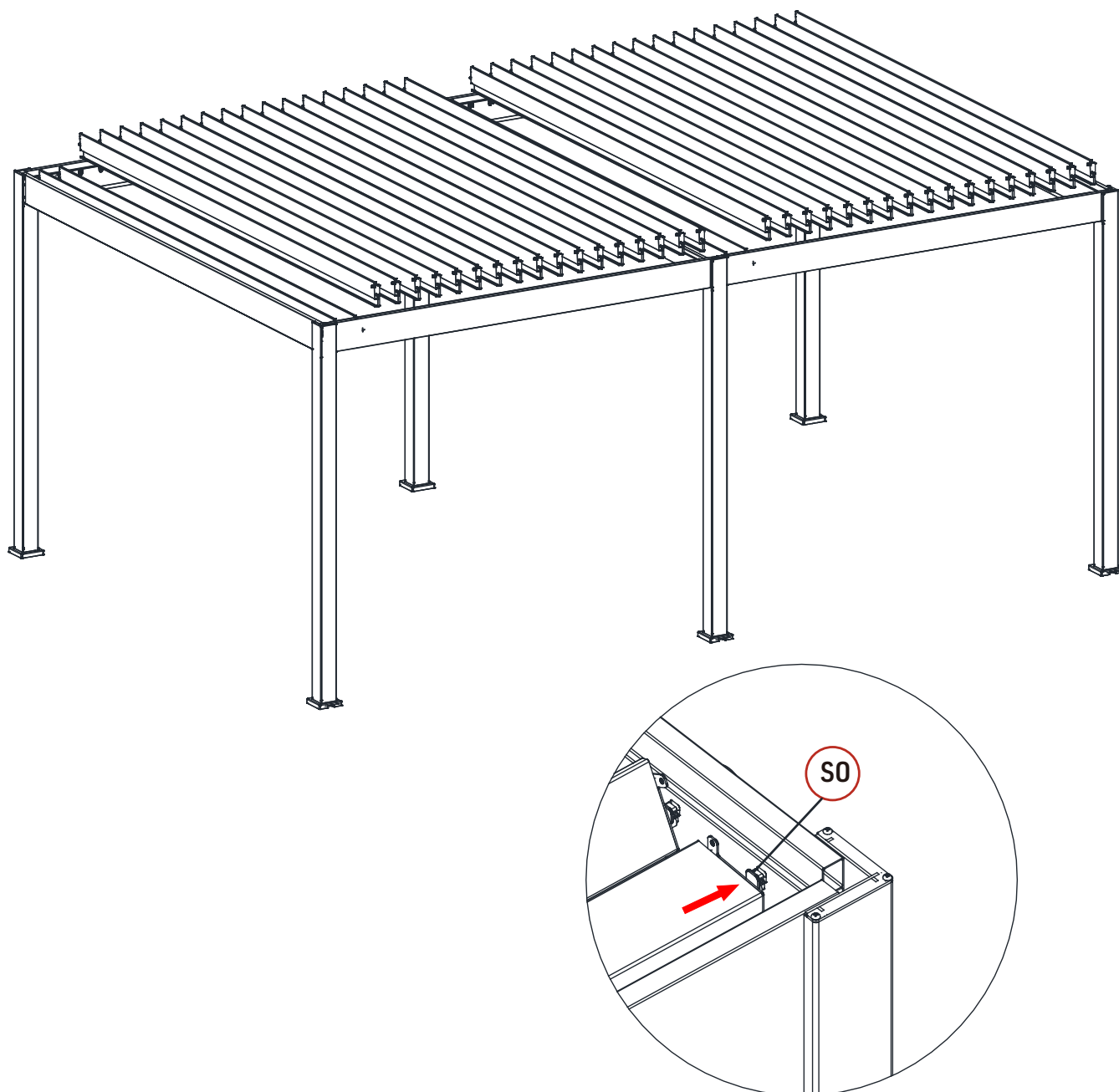

Mettre la lame en position verticale, afin d'installer les autres lames les unes après les autres. Puis, insérer les cales demi-lune **SO** comme indiqué sur le schéma. L'ouverture en demi-lune doit se situer sur la partie inférieure de la cale.

Répéter l'opération pour la seconde moitié de la pergola.

Fixer la visserie **XO-2**, **VO** et **UO-1** dans chaque cache-lame, comme indiqué sur le schéma.

Puis, fixer la barre de connexion **FO** sur toutes les lames avec les rondelles **VO** et les écrous **UO**, à l'aide d'une visseuse et de l'embout T20 **ZO-6** et de la clé **ZO-5** pour maintenir l'écrou.

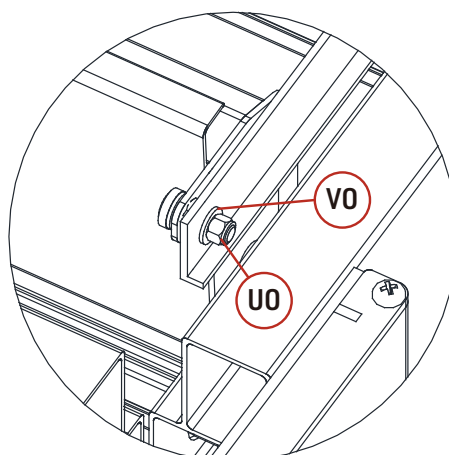
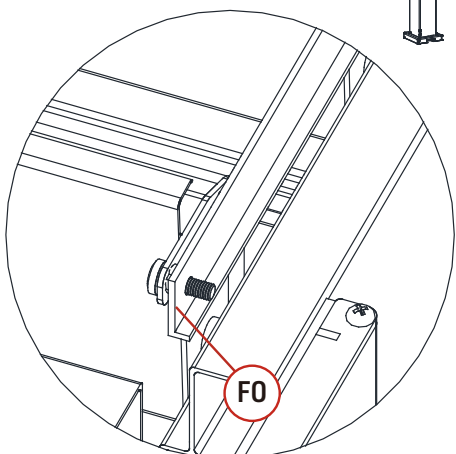
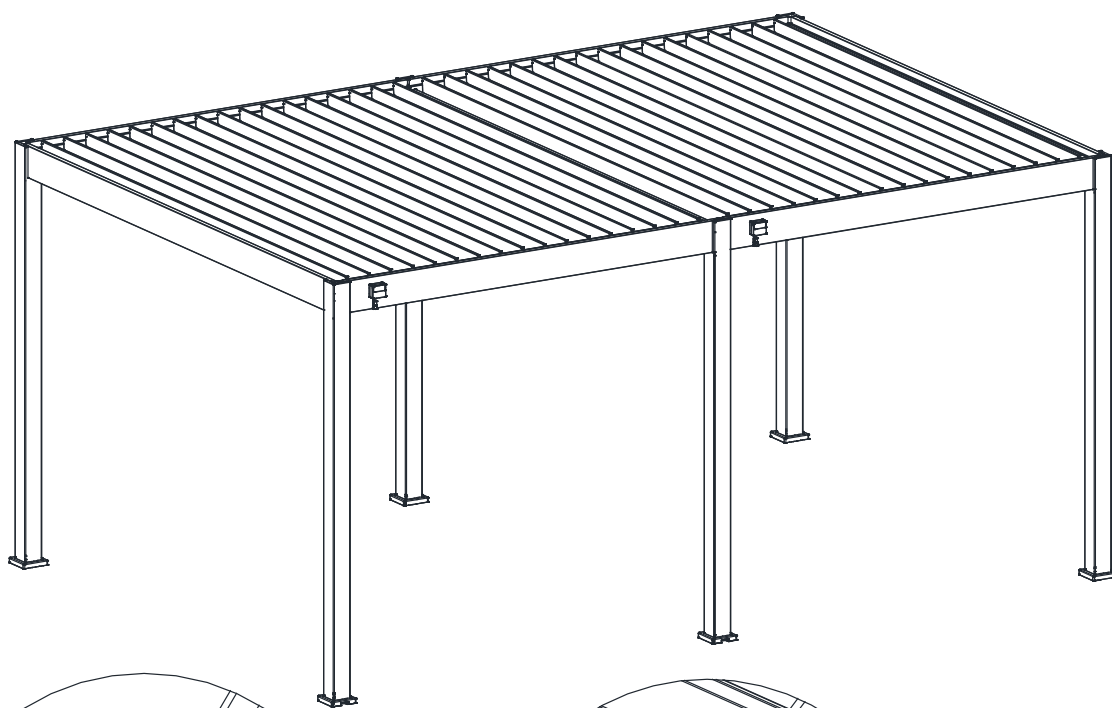
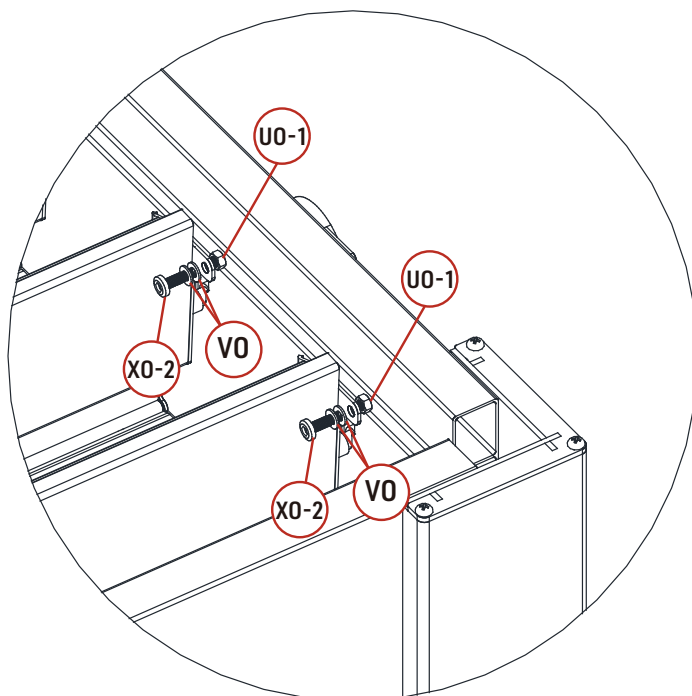
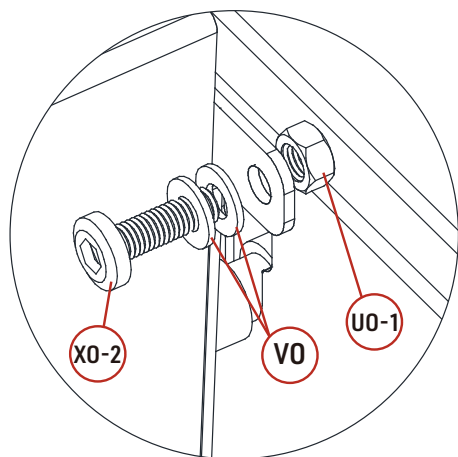

Insérer les boutons de finition **RO** pour masquer les trous situés dans les coins du cadre, comme indiqué sur le schéma.

Puis, emboîter la seconde partie du boîtier **OO** pour le refermer.

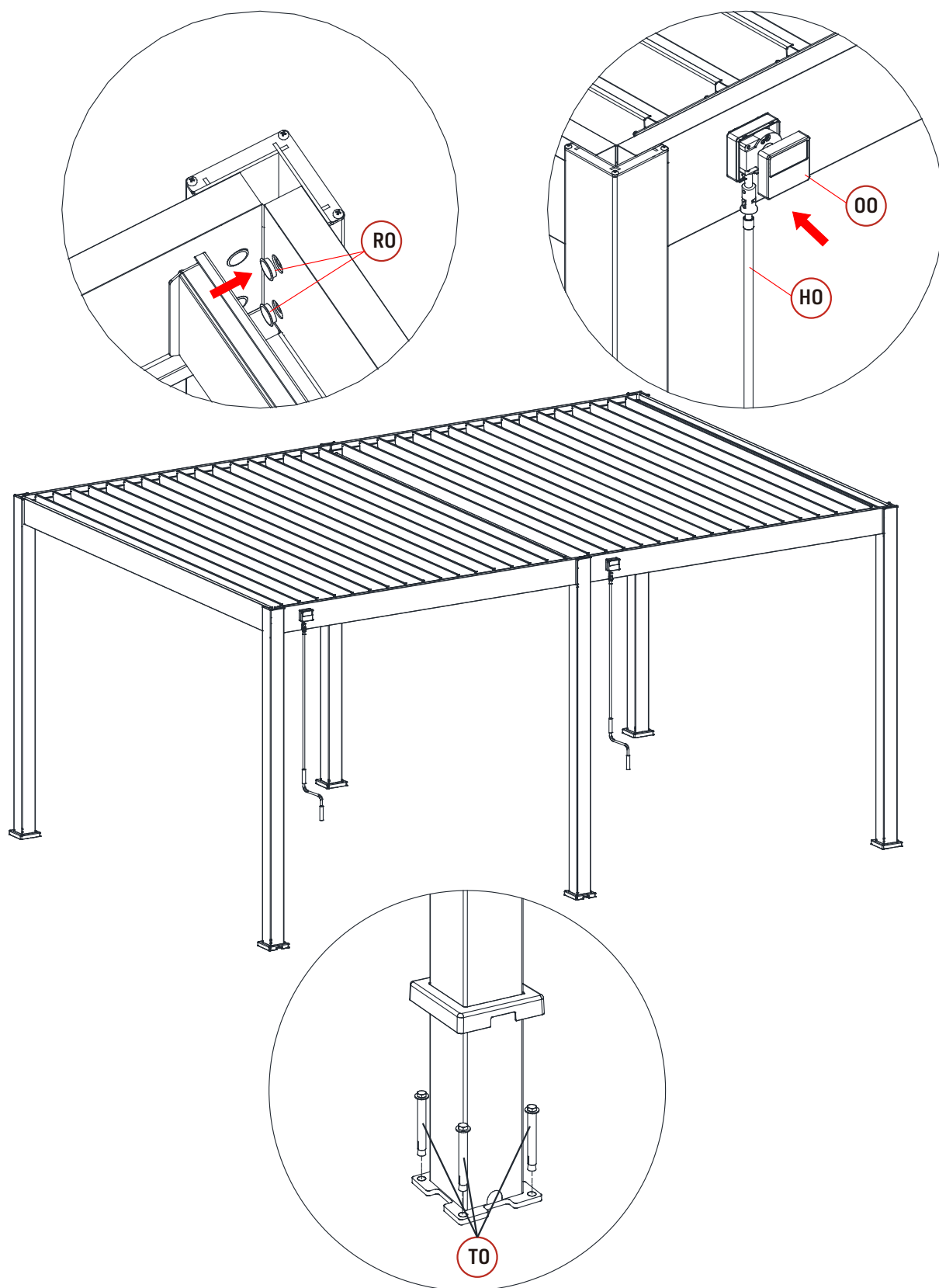

Terminer en fixant la pergola sur un sol dur et plat en béton, avec les chevilles à expansion **TO** à l'aide d'un perforateur et d'un foret 12mm (non fourni).

4x6M freestanding louvered pergola

Dark Grey : 15-728783 / White : 15-728868 / Dark Grey and White : 15-728943

These instructions have to be saved during the whole product life cycle.

We advise you to read these very carefully before proceeding to the assembly.

The user will be reliable for any damages or injuries caused due to incorrect or improper installation.

1. PRECAUTION OF USE

This product should not be used in extreme weather: storms, violent winds, hail, and snow. We guarantee the resistance of the pergola for winds up to 100 km/h and a maximum snow weight of 50kg/m².

As in the case of strong winds or snow, we highly recommend leaving the louvers open. In the case of omission or neglect the pergola will have to be cleared of any snow to avoid any overload on the louvers.

Our pergola can withstand heavy rain, but we cannot guarantee it will be 100% waterproof.

Exceptional climatic events may compromise the perfect sealing of the product.

We advise you not to leave products that are sensitive to humidity under the pergola.

We do not recommend climbing on the roof or the structure of the pergola, risking damage and may cause injuries.

2. TIPS AND SAFETY INSTRUCTIONS

Depending on the location and surface area, construction may be subject to building permits. Make sure you have checked with your local authorities to obtain the needed information before the assembly.

Product assembly :

- At least 2/3 people required
- Remove protective film (around 1 hour needed)
- Do not keep children near the assembly area
- Beware of the risk of pinching.
- Do not tighten the screws before assembling the whole product
- All assembly steps must be carefully followed.
- Check the level of the structure on all sides
- Do not anchor the pergola before assembling the whole product

No changes can be made to the product. Products tampered with by the user are not covered by the warranty, thus being declared as void.

The location should be chosen carefully. It is recommended to avoid mounting your pergola on a rainy day, facing the prevailing winds, and under an overhanging tree.

The pergola must be mounted on a flat-level foundation. It is recommended to install it on a concrete slab or 25x25 cm concrete pads at each post. Please, anchor the pergola properly to the ground using TO parts.

If you would like to mount your pergola near your house or a building, please check the presence of gutters for water drainage.

We cannot guarantee that the pergola can ensure perfect sealing if rainwater from your gutter lines spills on it.

Should these instructions not be followed or only partially, the warranty will be voided by the seller.

3. MAINTENANCE

Regular maintenance is necessary to ensure its longevity and aesthetic appearance. we recommend to :

- Clean your pergola once or twice a year with fresh water using a sponge or cloth.
- Do not use detergent or an abrasive material.
- Check the tightness of the screws regularly (at least once a year).
- Oil fastening regularly (at least once a year).
- Make sure that nothing hinders the water flow in the gutters (leaves, branches...).
- Remove any water that might stagnate around the legs of the pergola (lift the posts skirts).

4. WARRANTY

Ombrea® guarantees the availability of the spare parts for 2 or 5 years (depending on the product). It only applies if the storage, assembly, use and maintenance instructions are respected.

This warranty does not cover :

- Normal wear and tear inherent from the products.
- Loss or breakage of any part during unpacking or installation.
- Lack of care, neglect, vandalism, impact with foreign body, force, contact with abrasives material, product aesthetics, disassembly, rebuilding or relocation.
- Force majeure: hail, high winds, storms, snow, floods, lightning etc...
- Product tampered with by the user.

The warranty only takes in account the replacement of spare parts or the provided product, no refund will be issued.

All warranty claims must be made at the sales outlet (store or website) where the product has been purchased.

5. PARTS LISTS (PER CARTON)



Before proceeding with the assembly of your louvered pergola, it is necessary to check that all parts listed are supplied and not damaged.

Any missing part must be reported within 10 days of delivery.



You can either go through your local outlet store or make the request directly on our website sav.comintes.com.

Do not discard the packaging without ensuring that the product is functioning properly.

CARTON 1/6 (POSTS AND LOOSE PARTS)

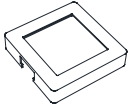
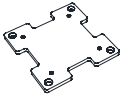
Reference	Parts	Quantity
AO	 POST	4
AO-1	 CENTRAL POST	2

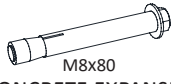

Reference	Parts	Quantity
IO	 POST SKIRTS	6
JO	 POST BASE PLATE	6



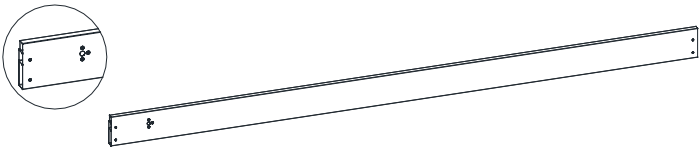
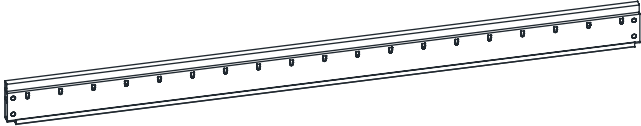
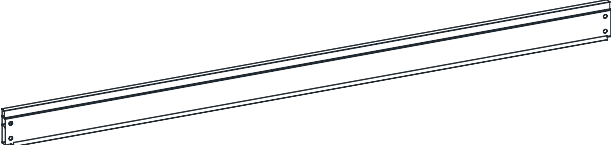



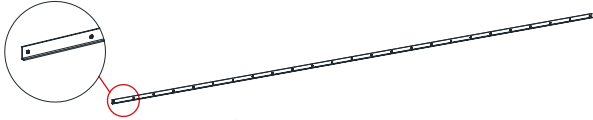



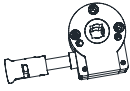





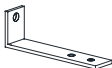

Reference	Parts	Quantity
TO	 M8x80 CONCRETE EXPANSION ANCHOR BOLT 80	24
XO-1	 6x35 BOLT 6X35	24

CARTON 2/6 (BEAMS AND LOOSE PARTS)

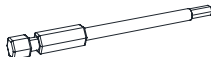
Reference	Parts	Quantity
BO-1	 MAIN BEAM	2
BO-2	 BACK BEAM	2
CO	 SIDE BEAM	2

CARTON 2/6 (BEAMS AND LOOSE PARTS)

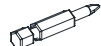

Reference	Parts	Quantity
EO	 CENTRAL BEAM	1
FO	 CONNECTOR BAR	2
HO	 CRANK HANDLE	2

Reference	Parts	Quantity	Reference	Parts	Quantity
NO	 GEARBOX	2	XO	 6x40 BOLT 6x40	74
OO	 BOX COVER	2	XO-2	 6x20 BOLT 6x20	38
PO	 CYLINDER	2	YO	 6x45 BOLT 6x45	6
QO	 BEAM FIXING SCREW	24	ZO-1	 4MM ALLEN KEY	1
QO-1	 STEEL BRACKET	2	ZO-2	 4MM HEX BIT	1
RO	 CIRCLE CAP	24	ZO-3	 6MM ALLEN KEY	1
SO	 HALF MOON PLASTIC CAP	76	ZO-4	 6MM HEX BIT	1
UO	 NUT	114	ZO-5	 10MM FLAT WRENCH	1
UO-1	 PLASTIC NUT	76	ZO-6	 T20 TORX BIT	1
VO	 WASHER	114	ZO-7	 SCREWDRIVER BIT	1

CARTON 3/6 (LOUVERS AND LOOSE PARTS)

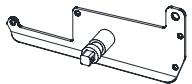
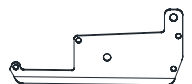
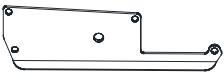
Reference	Parts	Quantity
GO	 LOUVER	8

Reference	Parts	Quantity
KO	 MAIN LOUVER END CAP	2
LO	 A LOUVER END CAP	36
LO-1	 B LOUVER END CAP	38

Reference	Parts	Quantity
MO	 SPRING PINS	74
WO	 4x16 BOLT 4x16	308
WO-1	 5x19 SELF-DRILLING SCREW 5x19	2

CARTON 4/6, 5/6 AND 6/6 (LOUVERS)

Reference	Parts	Quantity
GO	 LOUVER	10

The parts from aluminium are AO, AO-1, BO-1, BO-2, CO, FO, GO, IO, KO, LO et LO-1.

Screws, bolts, and other loose parts are either from stainless steel, galvanized steel, nylon, or plastic.

For any further information, make sure to refer to the technical specifications of the product and consult our FAQ page on the website www.pergola-ombrea.com or contact your outlet store.

6. NECESSARY TOOLS AND SAFETY GEAR (NOT SUPPLIED)



Safety glasses and Work gloves



2 Ladders



Electric drill + 12mm concrete drill bit



Electric screwdriver

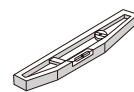

Spirit level



Cutter



Safety Helmet

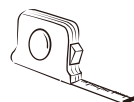

Tape measure

7. CONTACT

We gladly welcome feedback and suggestions from our clients in order to help us improve our services by email: contact@pergola-ombrea.com

We would be grateful to receive pictures of your installation.

We would like to thank you for your purchase and wish you happy days under your new brand Ombrea pergola !

8. FOOTING MEASUREMENT (dimensions in mm)

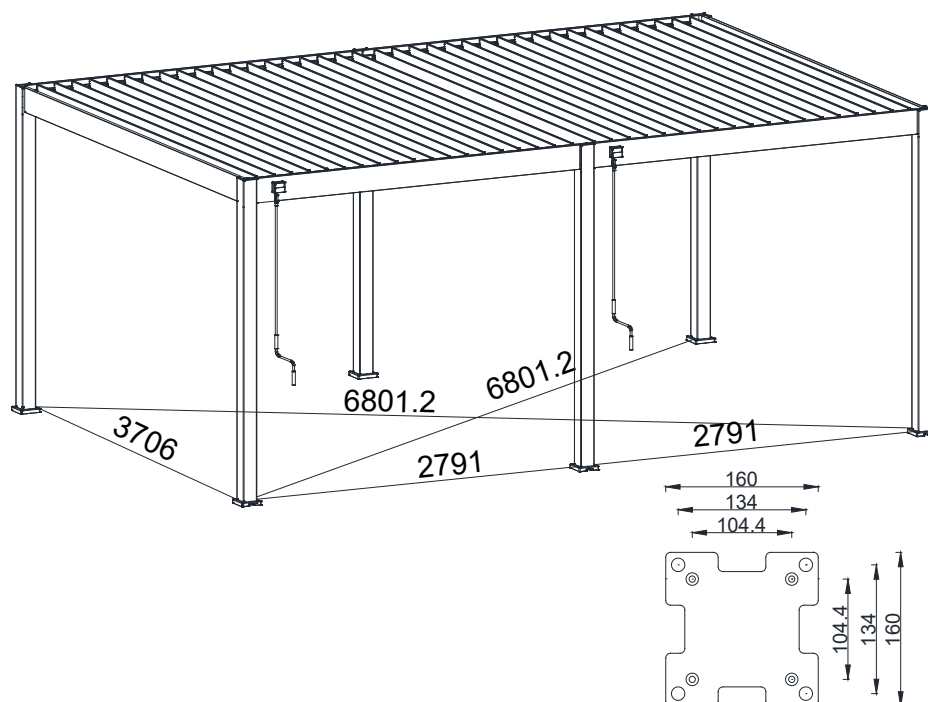
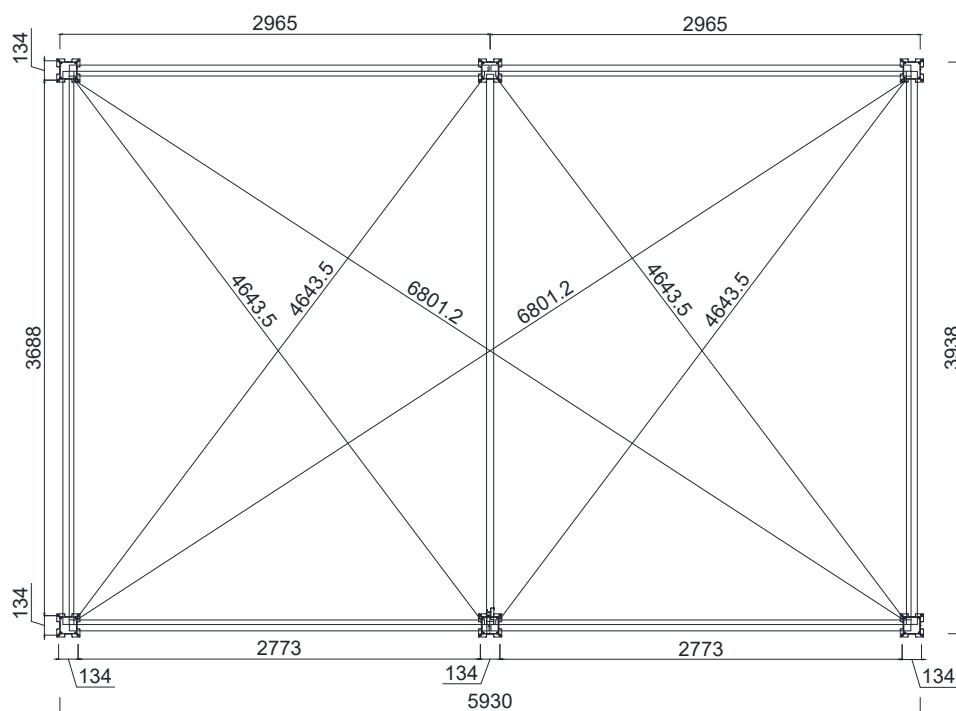

9. ÉTAPES DE MONTAGE

To prevent any damage to your pergola, we recommend to place the parts either on a table, trestles or a smooth and clean surface.

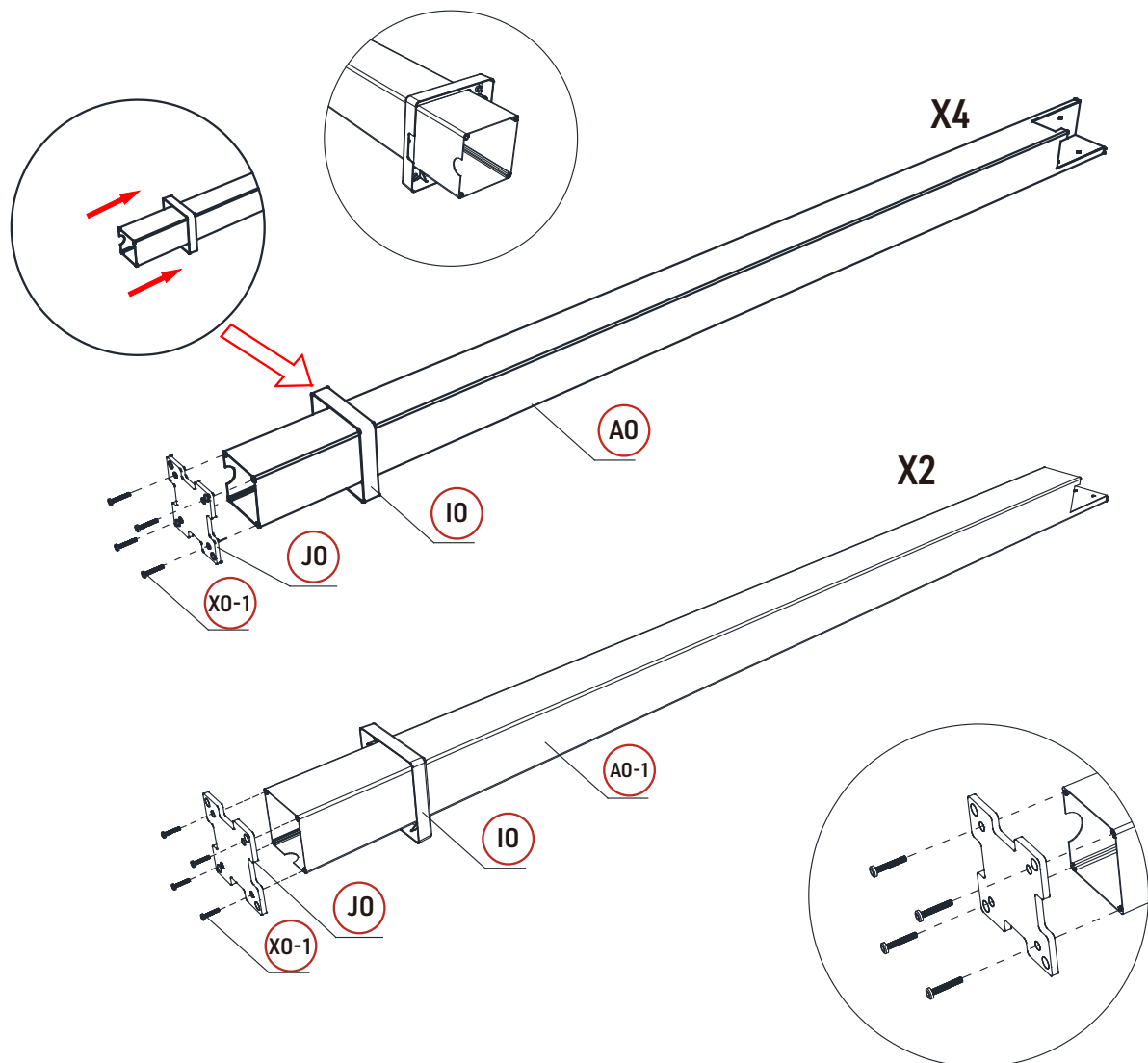

Insert and slide the post skirts **IO** onto the posts **AO**. The opening of this part should stay on the same side as the crescent opening located on the bottom of the post.

Fasten the post base plate **JO** with the bolt **XO-1** by using an electric screwdriver.

Place and fasten the beam **BO-1** on the posts **AO**, with the beam fixing screw **QO** by each corner using an electric screwdriver and hex bit **ZO-4** or Allen key **ZO-3**.

Repeat the process for the second time with the same remaining parts.

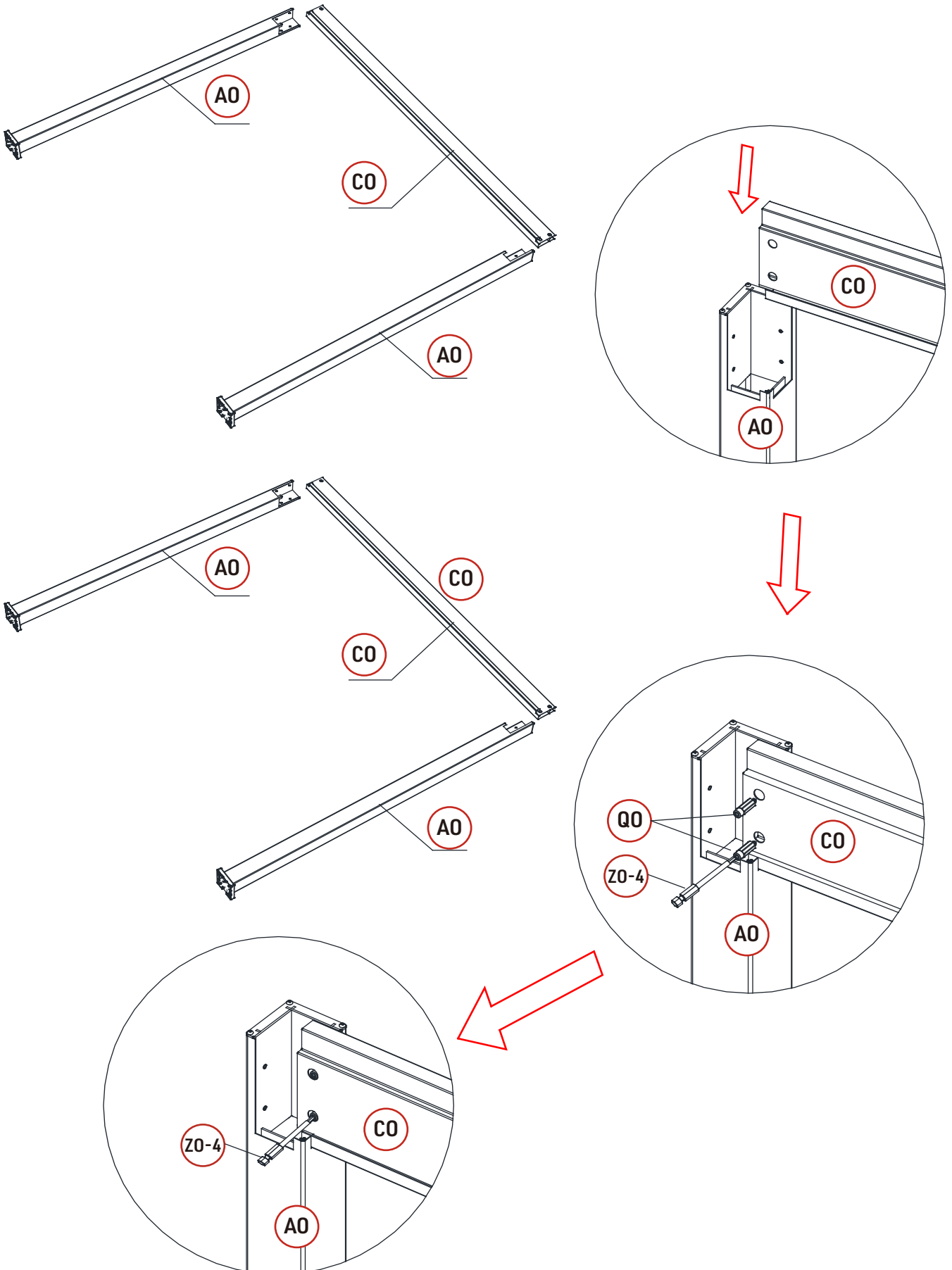

Together with at least 2/3 people, add the beams **BO-1** and **BO-2** onto the posts **AO** and **AO-1** as shown in the drawing. Fasten with the screws **QO** using an electric screwdriver and hex bit **ZO-4** or Allen key **ZO-3**.

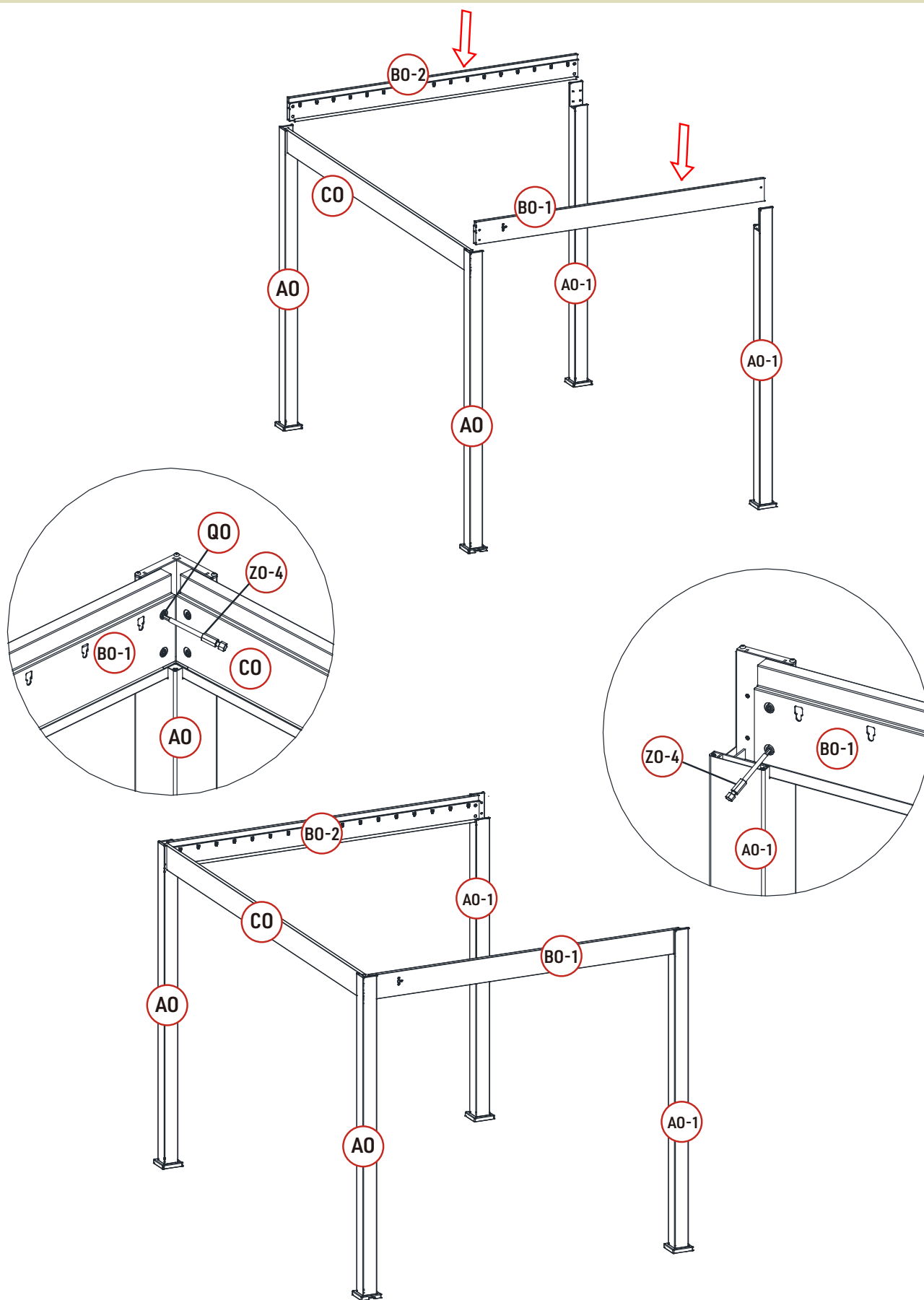

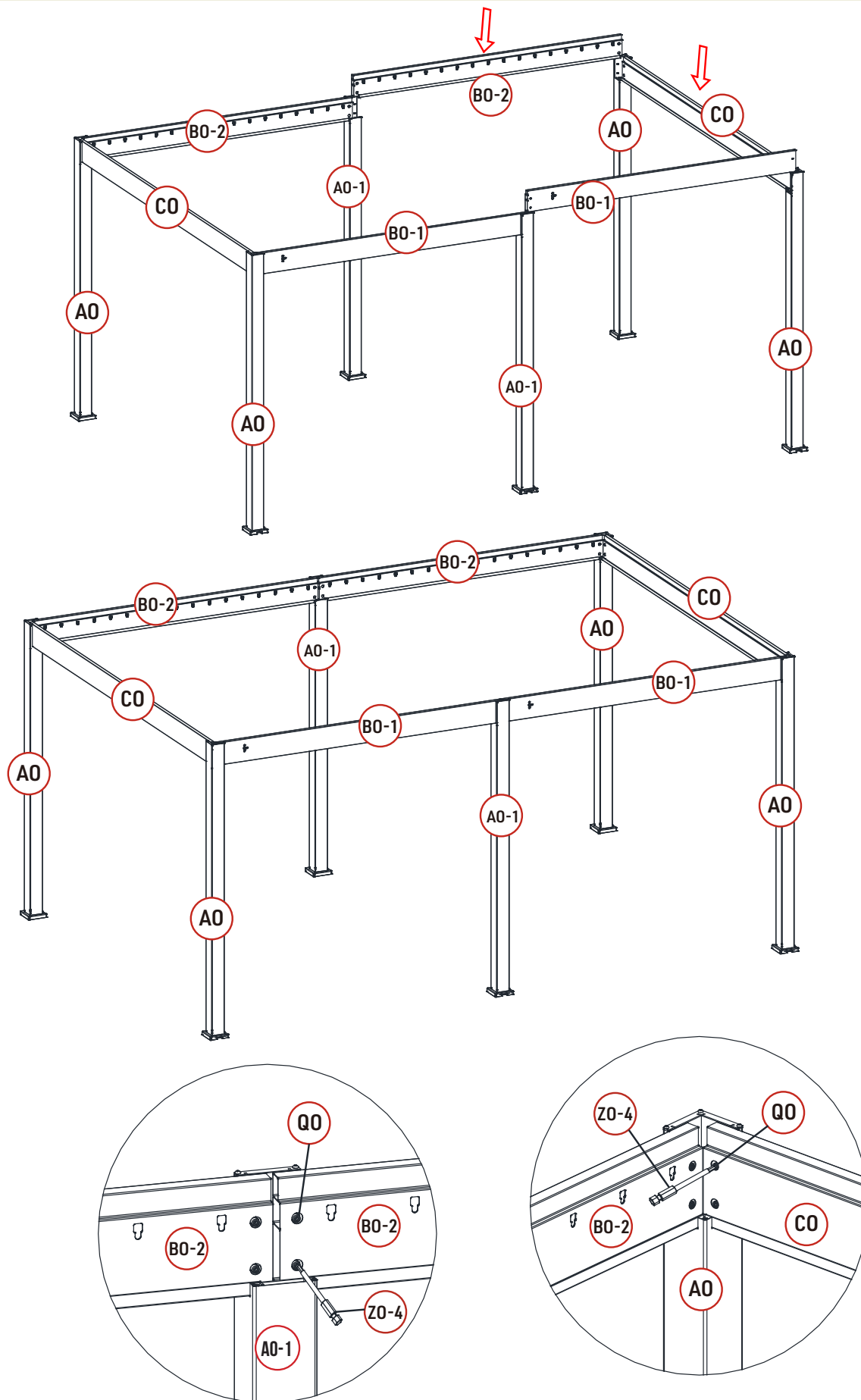

Close the frame as shown in the drawing, by building the second part of the pergola with the beams **BO-1** and **BO-2**. Fasten to one side to the post **AO** and another side to the post **AO-1** with the screw **QO**, using an electric screwdriver and the hex bit **Z0-4** or the Allen key **Z0-3**.

Fasten the steel bracket **QO-1** in the right direction, at the ends of the central beam **EO** with the screws **WO**.

Place and wedge the beam **EO** in the center of the frame onto the posts **AO-1**, then, using a screwdriver and the bit **ZO-7**, fasten the steel bracket **QO-1** onto the beams **BO-1** and **BO-2** with the Self-drilling screw **WO-1**, as shown on the drawing.

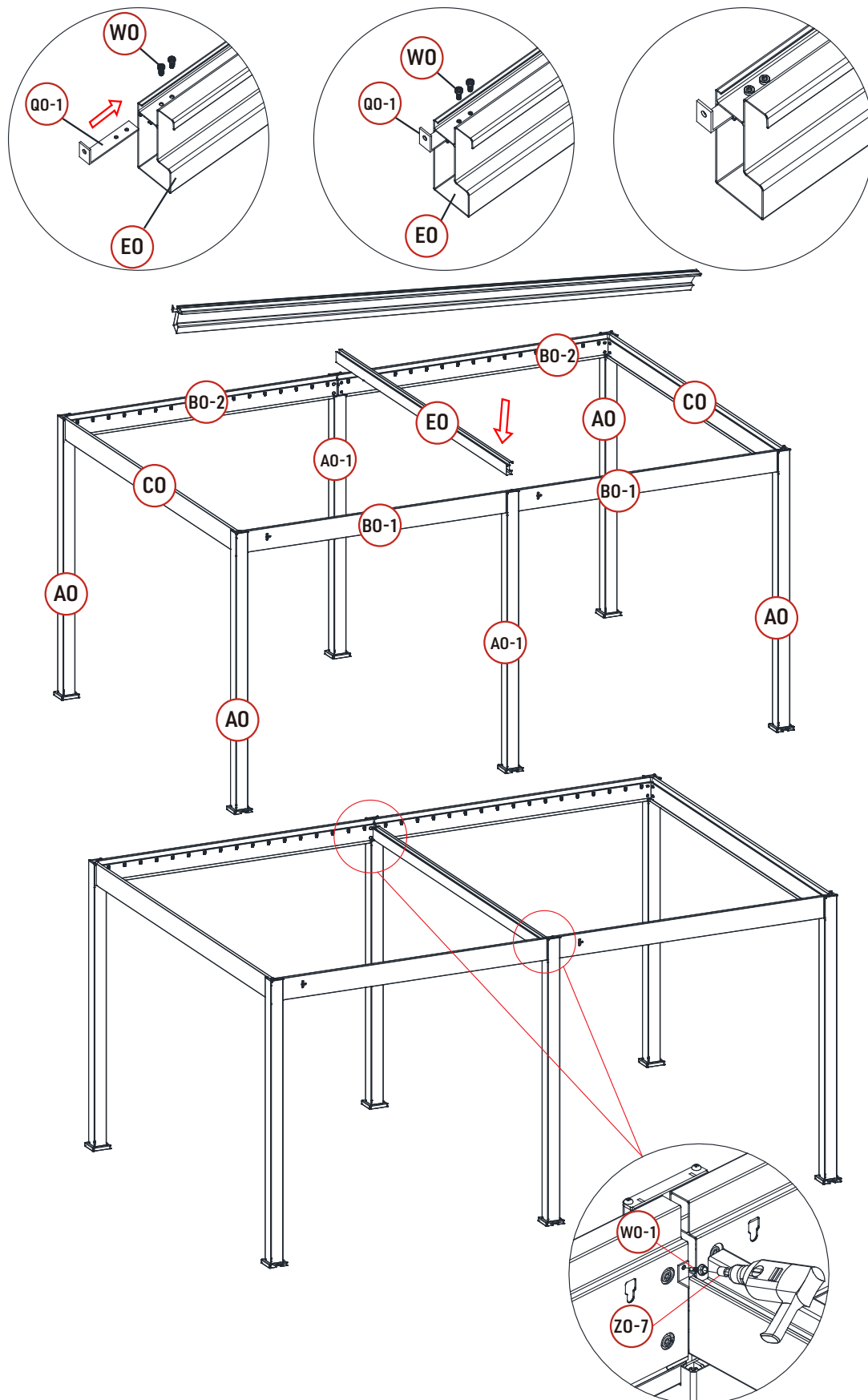

Build the pin composed of the parts **XO**, **MO** and **UO** onto the end caps **LO** and **LO-1**. Make sure the pins are installed in the right direction as shown. Please, note that the direction is different for the parts **LO** and **LO-1**.

Use an electric screwdriver with the hex bit **ZO-2** to insert the bolt **XO** onto the nut **UO** for more convenience. To avoid any injury and to make it easier, we recommend you to secure the nut with the wrench **ZO-5** during this operation.

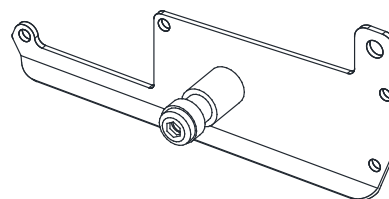
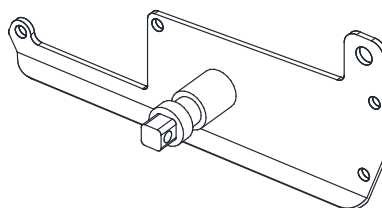
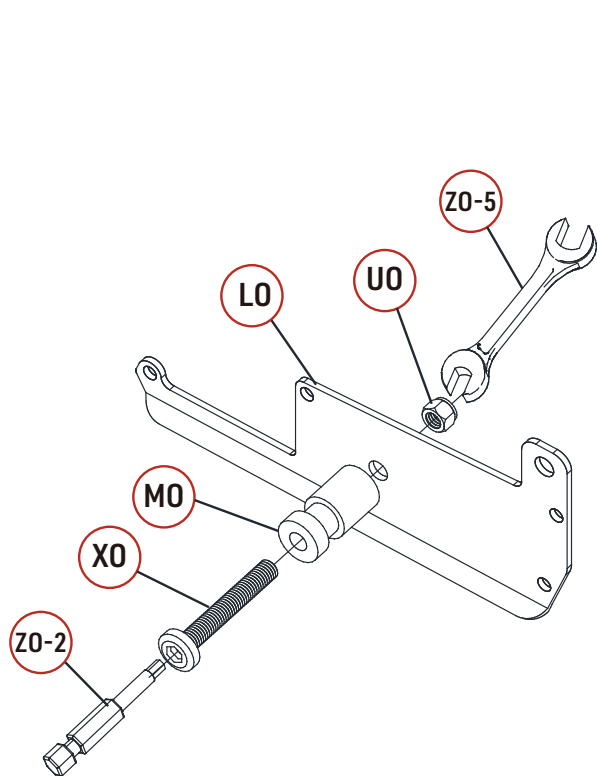

X36

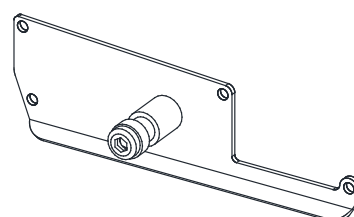
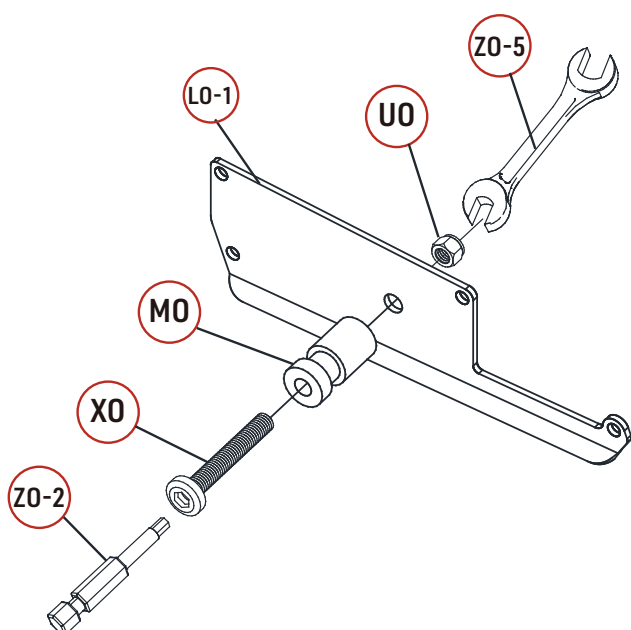

X38

Place the main louver **GO** into the right direction as shown, then fasten the main end cap **KO** onto the right side of the louver and **LO-1** onto the left side, with the screws **WO** using a screwdriver and the T20 **ZO-6**.

X2

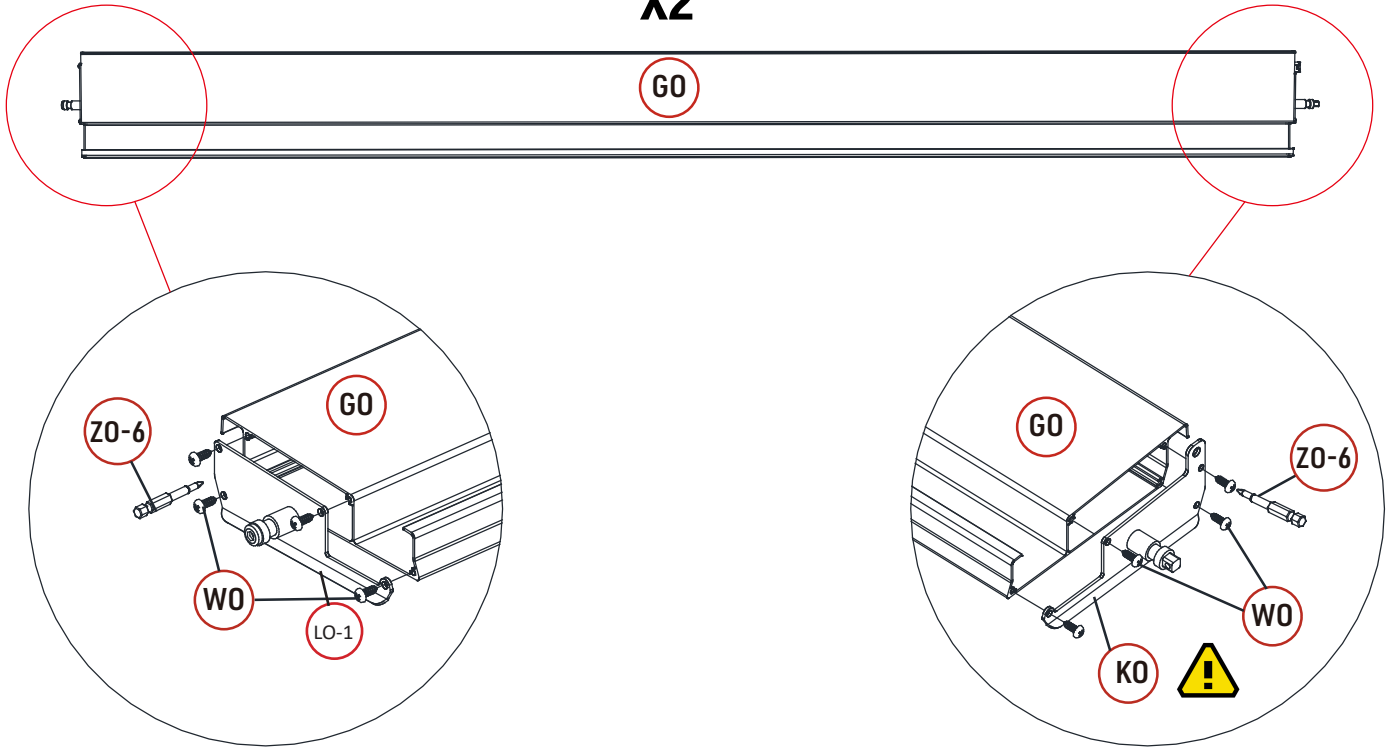

Repeat the same process with all louvers **GO** by fastening the end-caps **LO-1** on the left and the **LO** on the right.

X36

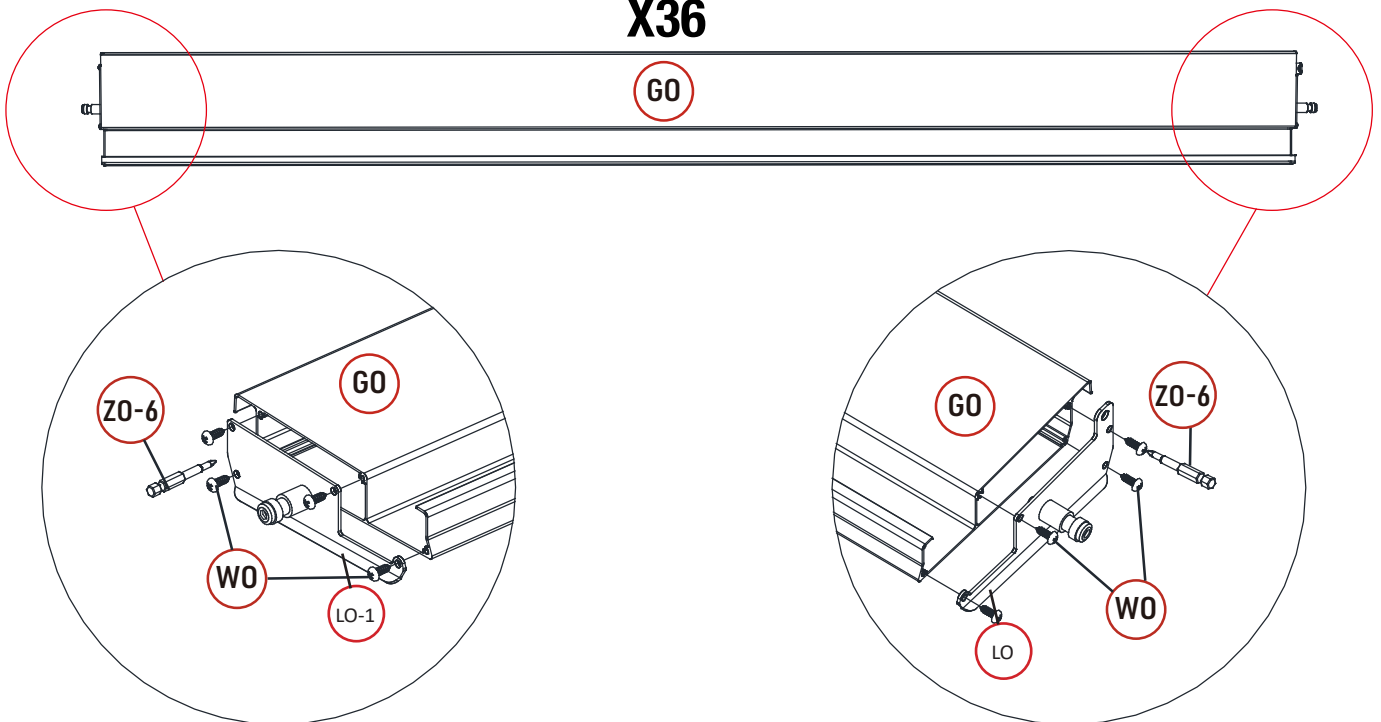

Place and insert the main louver at the 2nd position provided for this purpose, starting from the box side to build the roof.

Then, repeat the process for the second half of the pergola.

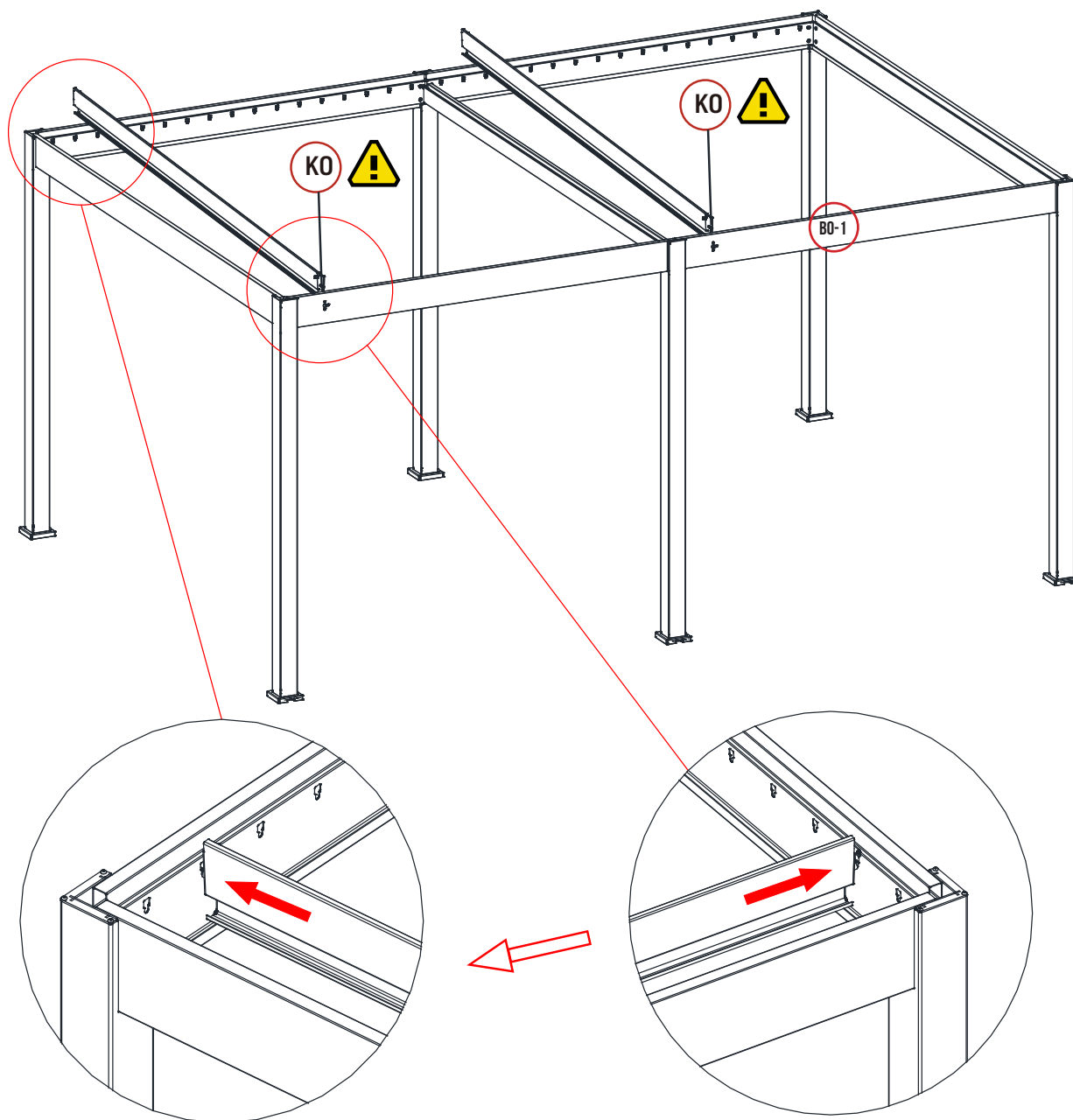

Insert the cylinder **PO** through the beam as shown in the drawing, then push the part until the connection with the pin from the main louver **KO**.

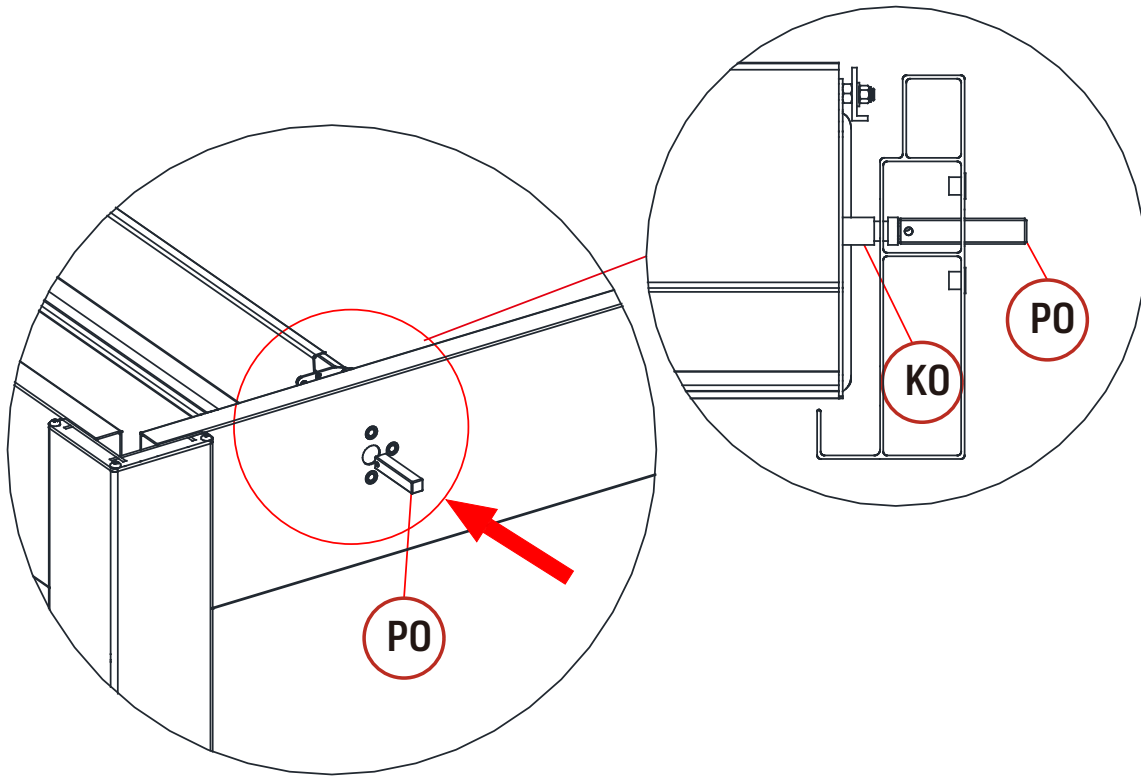

Combine and fasten the first part of the box **OO** with the Gearbox **NO** onto the beam **BO-1** with the bolts **YO**, using the Allen key **ZO-3** or a screwdriver and the hex bit **ZO-4**.

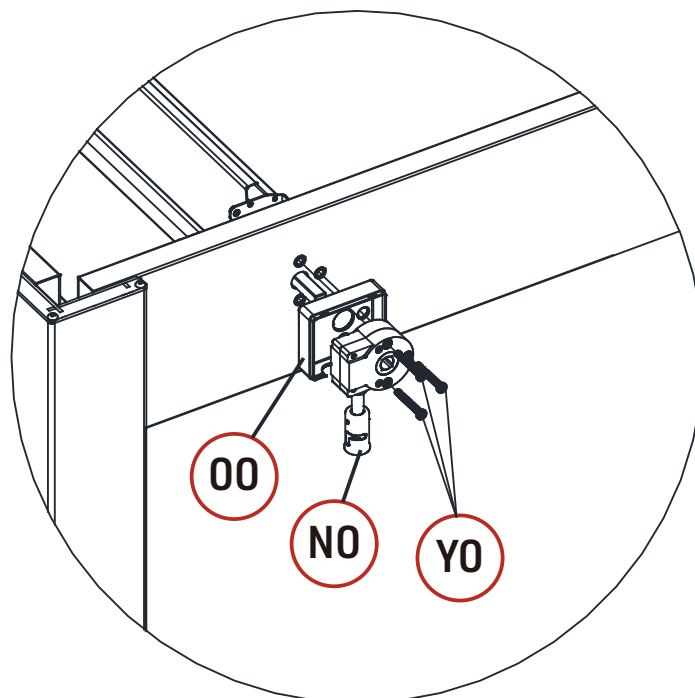

Then, repeat the process for the second half of the pergola.

Check if the louver rotates correctly from left to right and vice-versa using the hand crank **HO**.

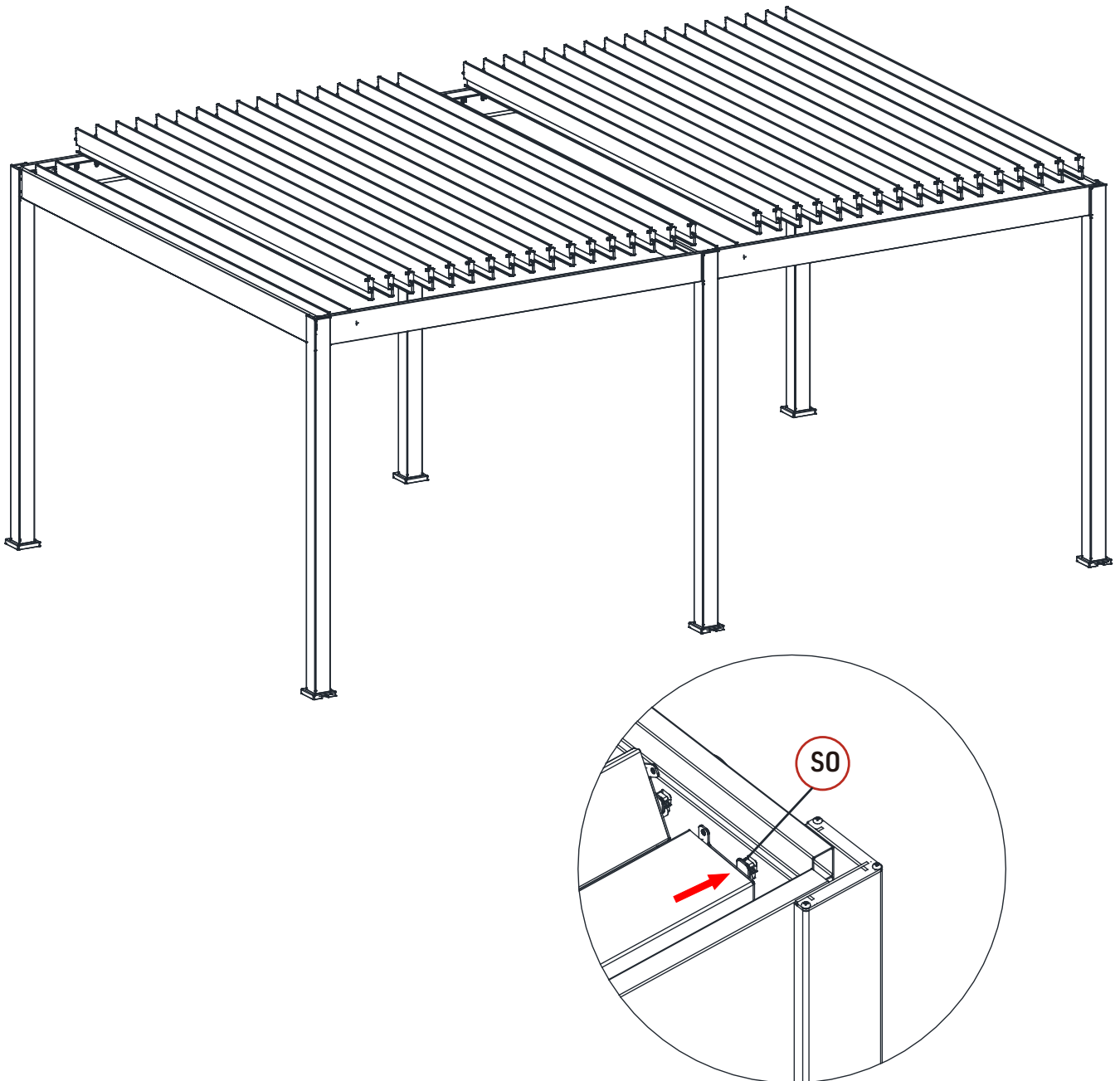

Place the louver in a vertical position, in the right direction as shown to place and insert the remaining louvers one after one. Then, insert the half-moon plastic cap **SO** as shown in the drawing. The half-moon opening should stay at the bottom of the cap.

Repeat the process for the second half of the pergola.

Fasten the screws and bolts **XO-2**, **VO** and **UO-1** into each louver end cap, as shown in the drawing. Then, fasten the connector bar **FO** onto each louver with the washers **VO** and the nut **UO** as shown, using a screwdriver with the T20 **ZO-6** and the wrench **ZO-5** to secure the nut.

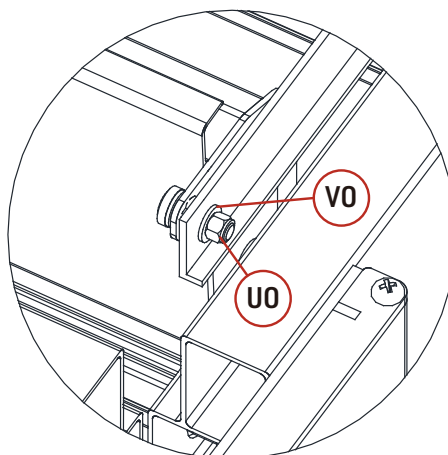
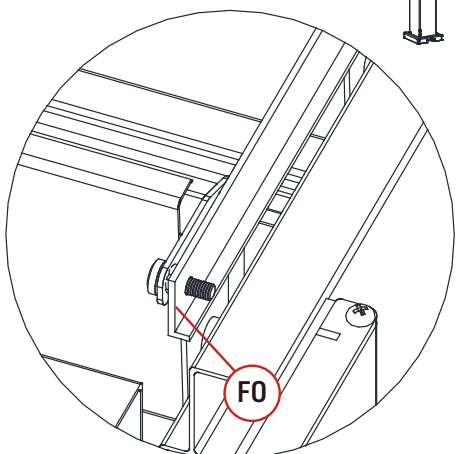
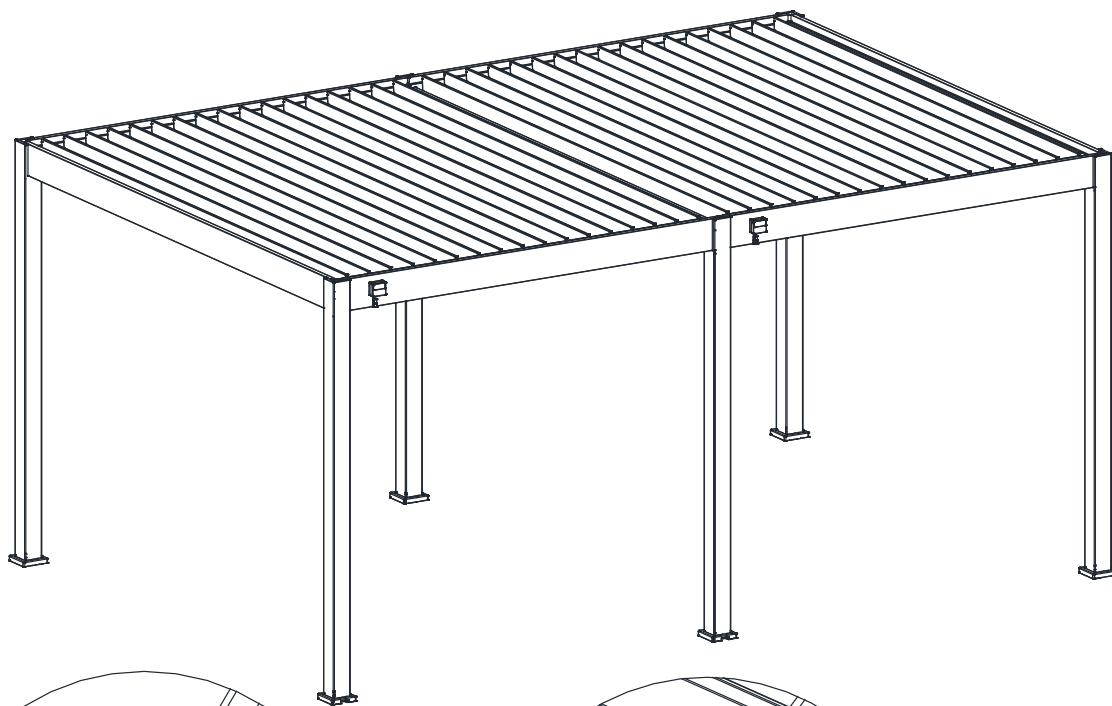
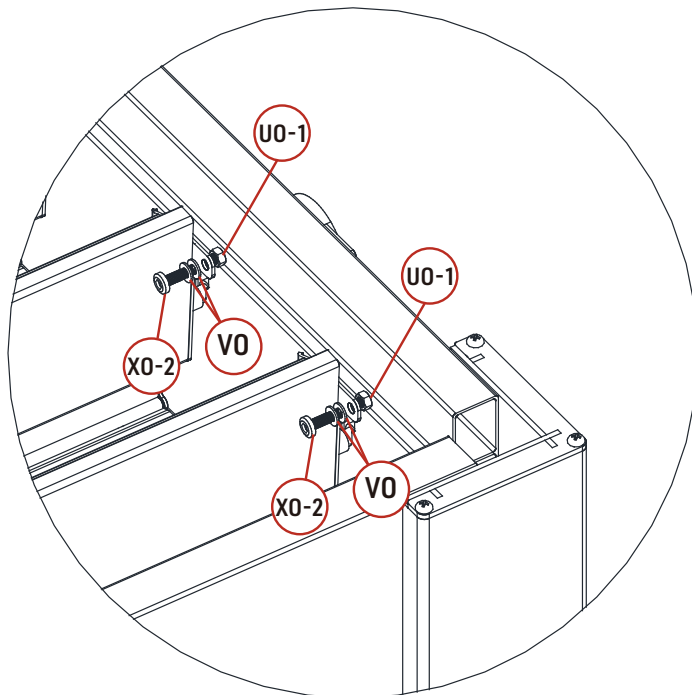
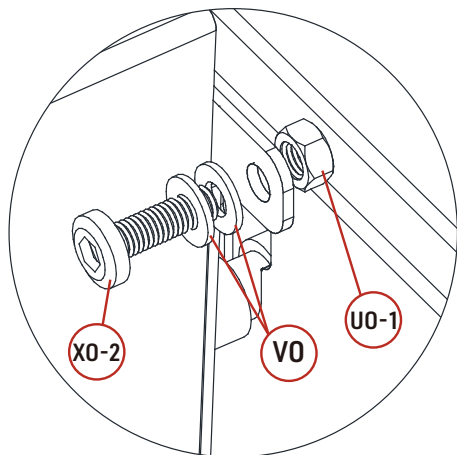

Insert the button cover **RO** on the corner of the frame as shown in the drawing.
Then, clip on the second part of the box **OO** to close the part.

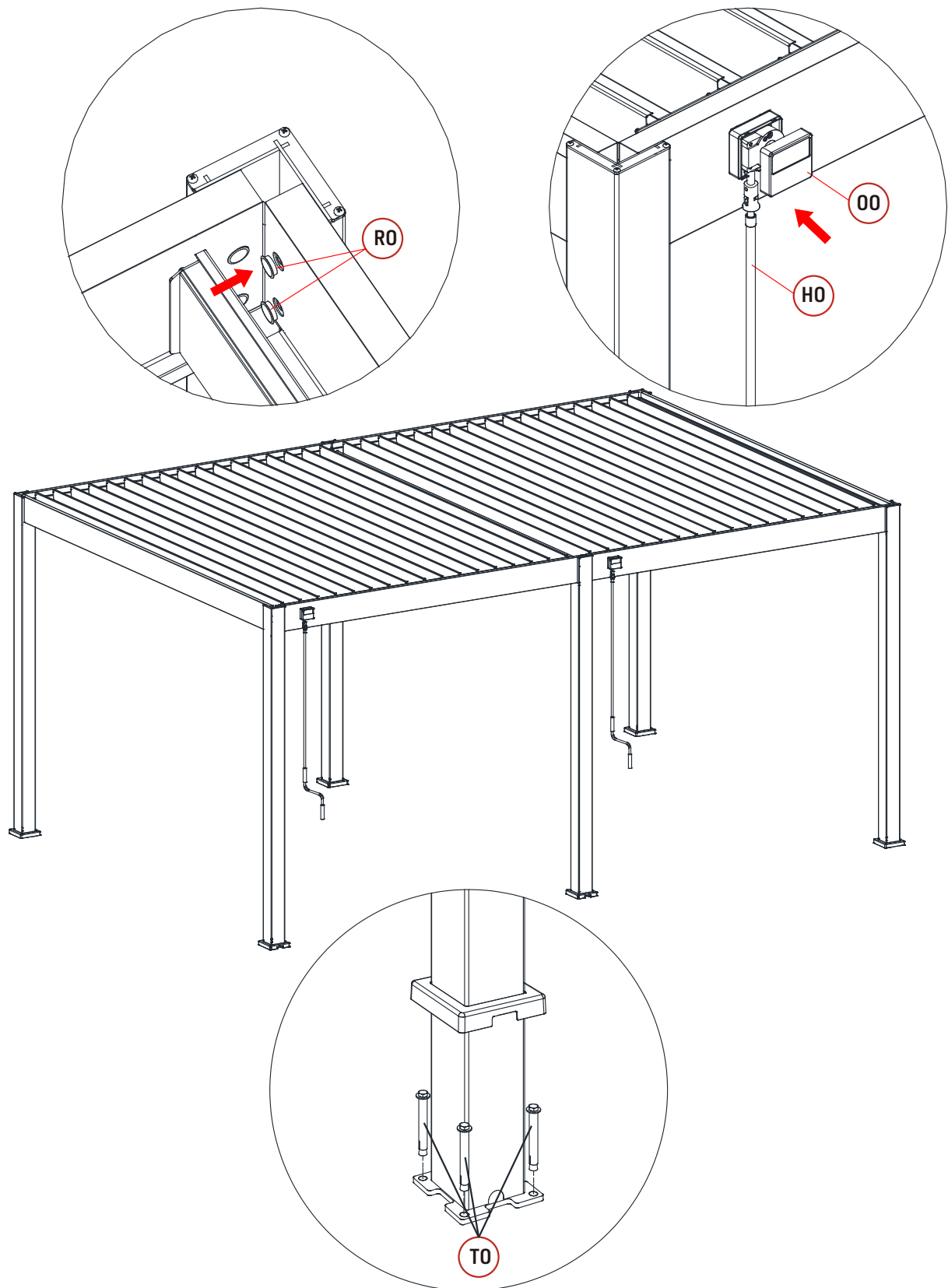

End by anchoring the pergola on a hard and flat concrete floor with the concrete expansion anchor bolts **TO**, using an electric drill and the 12mm Drill bit (not supplied).

Pérgola Bioclimática Autoportante 4x6M

Antracita : 15-728783 / Blanco : 15-728868 / Antracita y Blanco : 15-728943

Le aconsejamos conservar estas instrucciones para consultas futuras.

Le rogamos leer atentamente estas instrucciones antes de empezar el montaje.

El cliente será responsable de cualquier daño o lesión ocasionada por un uso inadecuado del producto.

1. PRECAUCIONES DE SEGURIDAD

Este producto no debe usarse en condiciones climáticas severas: tormenta, viento fuerte, granizo, nieve. Garantizamos la resistencia de la pérgola para soportar vientos hasta 100 km/h y un peso máximo de nieve de 50 kg / m².

En caso de viento o nieve violento, se recomienda dejar las lamas en posición abierta. Si se olvida, habrá que quitar la nieve de la pérgola para evitar una sobrecarga significativa en las lamas.

Nuestra pérgola puede soportar lluvias fuertes, no obstante, no podemos asegurar una impermeabilidad al 100%.

En caso de fenómenos meteorológicos excepcionales, su estanqueidad puede verse comprometida. No guarde enseres que temen la humedad debajo de la pérgola. No se sube al tejado ni a la estructura de la pérgola.

2. MONTAJE

Dependiendo de la ubicación y la superficie, las construcciones pueden estar sujetas a una solicitud de permiso de obra. Ponerse en contacto con las autoridades locales para determinar si la instalación está autorizada.

Montaje del producto :

- Se necesitan de 2 a 3 personas.
- Mantenga a los niños lejos de la zona de montaje.
- Tenga cuidado con el riesgo de pellizcos. Llevar siempre guantes de protección.
- Nunca apriete completamente los tornillos antes de haber ensamblado la pieza en cuestión.
- Es importante seguir estas instrucciones paso a paso.

No se pueden realizar modificaciones en el producto. Los productos modificados por el cliente no están cubiertos por la garantía del fabricante.

La ubicación debe elegirse de forma adecuada. Se recomienda evitar montar su pérgola de cara a los vientos dominantes y debajo de un árbol.

La pérgola debe montarse sobre una superficie estable y nivelada, se recomienda instalarla sobre una losa de hormigón o soportes de hormigón al nivel de cada poste. Le pedimos que ancle correctamente la pérgola al suelo utilizando las piezas TO.

Si desea colocar su pérgola cerca de su casa o edificio, le pedimos que verifique la presencia de canales de desagüe.

La pérgola no podrá resistir y garantizar una estanqueidad perfecta si el agua de lluvia de su hogar fluye hacia ella.

En caso de incumplimiento de las recomendaciones de montaje, no se podrá aplicar la garantía.

3. MANTENIMIENTO

Es necesario un mantenimiento regular para asegurar la longevidad y conservar el aspecto estética inicial del producto.

Recomendamos:

- Clean your pergola once or twice a year with fresh water using a sponge or cloth.
- Do not use detergent or an abrasive material.
- Check the tightness of the screws regularly (at least once a year).
- Oil fastening regularly (at least once a year).
- Make sure that nothing hinders the water flow in the gutters (leaves, branches...).
- Remove any water that might stagnate around the legs of the pergola (lift the posts skirts).

4. GARANTÍA

Ombrea® garantiza la disponibilidad de las piezas de repuestos durante 2 ó 5 años (según el producto). La garantía solo se aplicará si el almacenamiento, montaje, uso de forma normal y mantenimiento regular se respetan.

Exclusión de la garantía:

- El desgaste normal inherente a los productos.
- Pérdida o rotura de cualquier pieza durante el desembalaje o la instalación.
- Falta de mantenimiento, negligencia, vandalismo, impactos con objetos extraños, uso de fuerza, contacto con abrasivos, estética, desmantelamiento, reconstrucción o reubicación.
- Fuerzas mayores: granizo, vientos fuertes, tormentas, nieve, inundaciones, rayos ...

La garantía se limita a la sustitución de piezas de repuestos o del producto suministrado, excluyendo todo gastos y compensaciones de cualquier tipo.

Todas las reclamaciones de garantía deben realizarse en el punto de venta (tienda o sitio web) donde se adquirió el producto.



5. LISTA DE PIEZAS (POR BULTOS)

Antes de proceder al montaje de su pérgola bioclimática, revise que todas las piezas están incluidas y no dañadas.

Cualquier pieza faltante debe informarse dentro de los 10 días posteriores a la compra. Puede reclamar a través de su distribuidor o enviar una solicitud directamente en nuestra página web sav.comintes.com.

No tire el embalaje sin asegurarse de que la pérgola está funcionando correctamente.

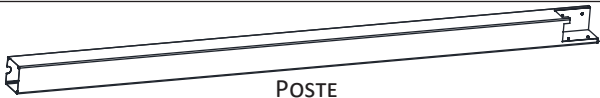
BULTO 1/6 (POSTES Y HERRAJES)

Referencias	Diagrama	Cantidad
AO	 POSTE	4
AO-1	 POSTE CENTRAL	2

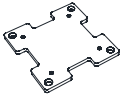

Referencias	Diagrama	Cantidad
IO	 FALDA DE POSTE	6
JO	 PLETINA DE SUJECIÓN	6



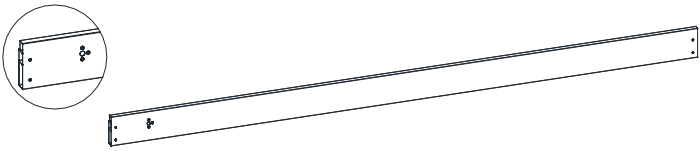
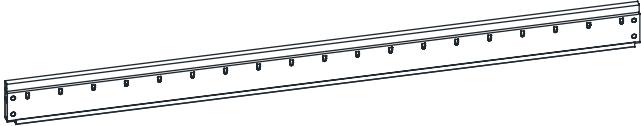
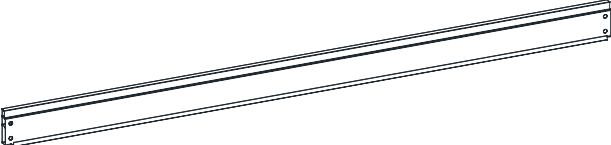



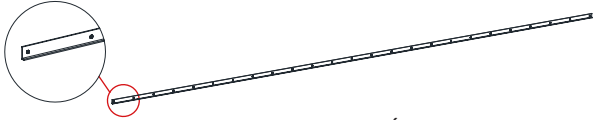



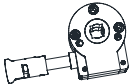







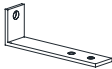

Référence	Diagrama	Cantidad
TO	 M8x80 TACO DE HORMIGÓN	24
XO-1	 6x35 PERNO 6X35	24

BULTO 2/6 (VIGAS Y HERRAJES)

Referencias	Diagrama	Cantidad
BO-1	 VIGA PRINCIPAL	2
BO-2	 VIGA TRASERA	2
CO	 VIGA LATERAL	2

BULTO 2/6 (VIGAS Y HERRAJES)

Referencias	Diagrama	Cantidad
EO	 VIGA CENTRAL	1
FO	 BARRA DE CONEXIÓN	2
HO	 MANIVELA	2

Referencias	Diagrama	Cantidad	Referencias	Diagrama	Cantidad
NO	 CAJA DE ENGRANAJES	2	XO	 PERNO 6X40	74
OO	 CAJA	2	XO-2	 PERNO 6X20	38
PO	 CILINDRO	2	YO	 PERNO 6X45	6
QO	 TORNILLO DE FIJACIÓN DE LA VIGA	24	ZO-1	 LLAVE ALLEN 4MM	1
QO-1	 PATA DE CONEXIÓN	2	ZO-2	 PUNTA DESTORNILLADOR 4MM	1
RO	 TAPA DE ACABAMIENTO	24	ZO-3	 LLAVE ALLEN 6MM	1
SO	 CUÑA DE MEDIA LUNA	76	ZO-4	 PUNTA DESTORNILLADOR 6MM	1
UO	 TUERCA	114	ZO-5	 LLAVE PLANA 10MM	1
UO-1	 TUERCA DE PLÁSTICO	76	ZO-6	 PUNTA DESTORNILLADOR T20	1
VO	 ARANDELA	114	ZO-7	 PUNTA DESTORNILLADOR	1

BULTO 3/6 (LAMAS Y HERRAJES)

Referencias	Diagrama	Cantidad
GO	 LAMA	8

Referencias	Diagrama	Cantidad	Referencias	Diagrama	Cantidad
KO	 TAPA DE LA LAMA PRINCIPAL	2	MO	 PASADOR	74
LO	 TAPA DE LA LAMA A	36	WO	 TORNILLOS 4x16	308
LO-1	 TAPA DE LA LAMA B	38	WO-1	 TORNILLO AUTOPERFORANTE	2

BULTO 4/6, 5/6 Y 6/6 (LAMAS)

Referencias	Diagrama	Cantidad
GO	 LAMA	10

Las piezas de aluminio son las siguientes: AO, AO-1, BO-1, BO-2, CO, FO, GO, IO, KO, LO y LO-1.

Los tornillos y demás piezas son de acero inoxidable, acero galvanizado, plástico o nailon.

Para más información, consulte las especificaciones técnicas del producto y nuestra página de preguntas frecuentes en www.pergola-ombrea.es o póngase en contacto con su distribuidor.

6. EQUIPO (NO SUMINISTRADO) NECESARIO PARA EL MONTAJE



Gafas y guantes de protección



2 escaleras de tijera



Taladro + broca para hormigón de 12 mm



Destornillador eléctrico

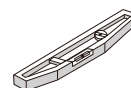

Nivel de burbuja

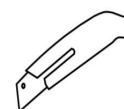

Cúter



Casco de seguridad

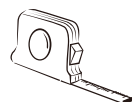

Cinta métrica

7. CONTACTO

Siempre estamos buscando formas de mejorar, así que no dudes en enviarnos tus comentarios y sugerencias a la siguiente dirección: info@pergola-ombrea.es

Estaremos encantados de recibir las bonitas fotos de tu instalación.

El equipo de Ombréa te agradece tu compra y te desea días de felicidad aprovechándote tu pérgola !

8. PLAN DEL MONTAJE (DIMENSIONES EN MM)

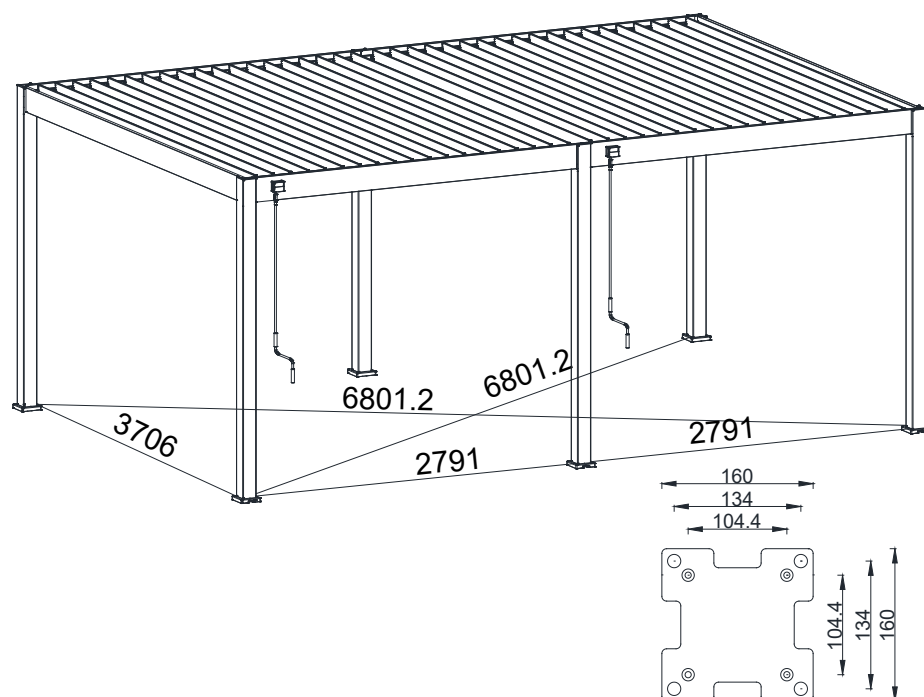
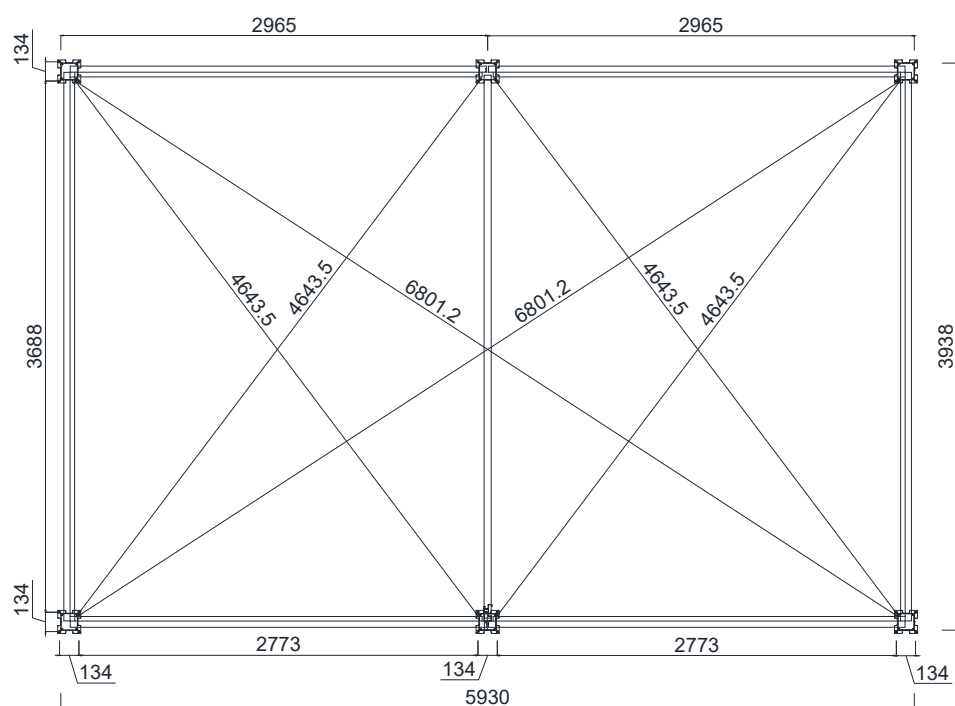

9. PASOS DE INSTALACIÓN

Para evitar daños en tu pérgola durante el proceso de montaje, te recomendamos que coloques las piezas sobre una mesa, caballetes y preparar una superficie plana y limpia.

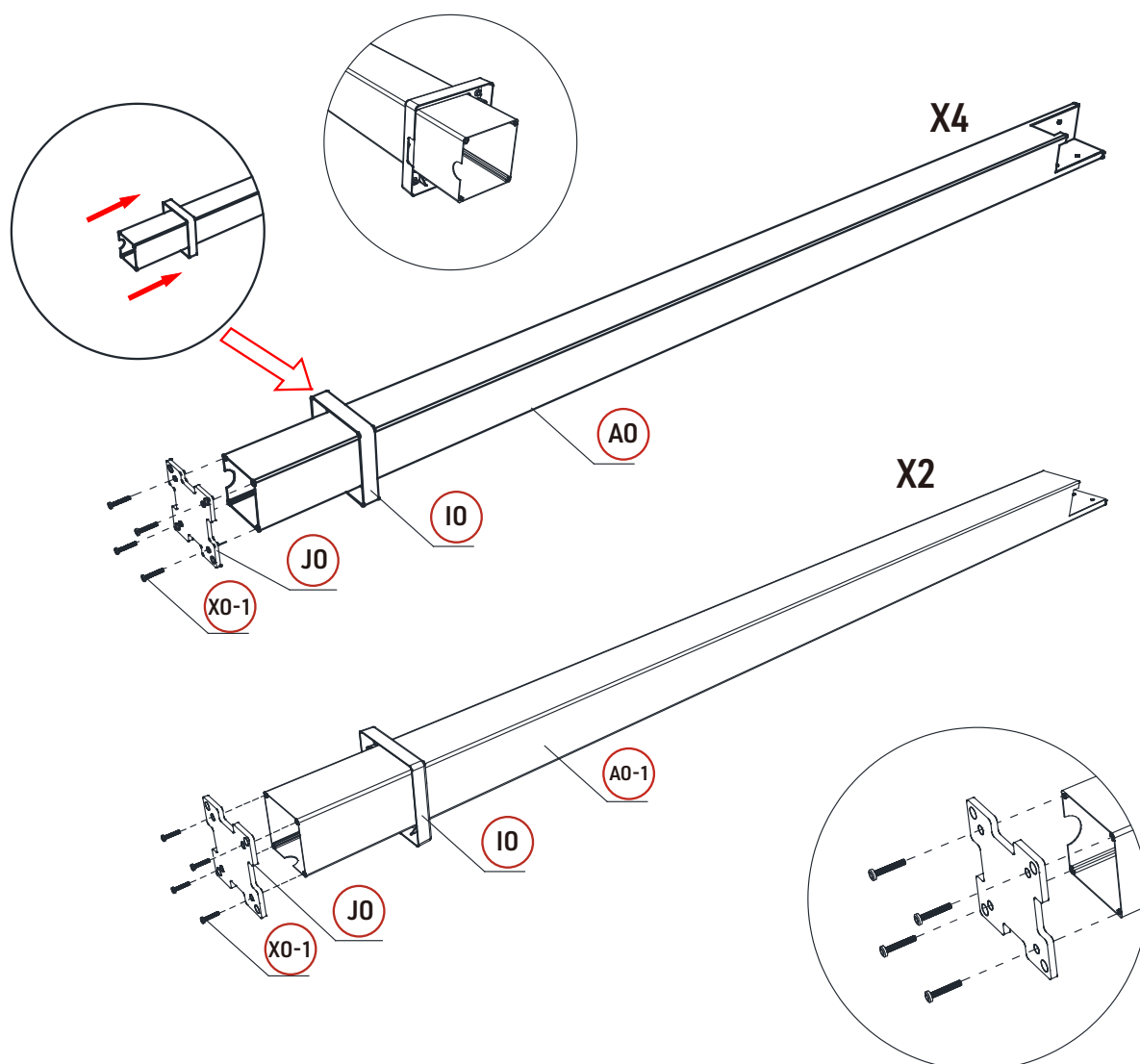

Desliza las faldas de poste **IO** en los postes **AO** y **AO-1**, colocando la abertura en la misma dirección que la abertura del poste de media luna.

A continuación, fija la platina **JO** con los tornillos **XO-1** utilizando un destornillador. Empieza apretando ligeramente, luego a fondo una vez que todos los tornillos estén colocados.

Posiciona y fija la viga **CO** en los postes **AO** con los tornillos **QO** de cada lado, utilizando un destornillador y la punta **ZO-4** o la llave Allen **ZO-3**.

Repita la operación una segunda vez con las mismas piezas restantes.

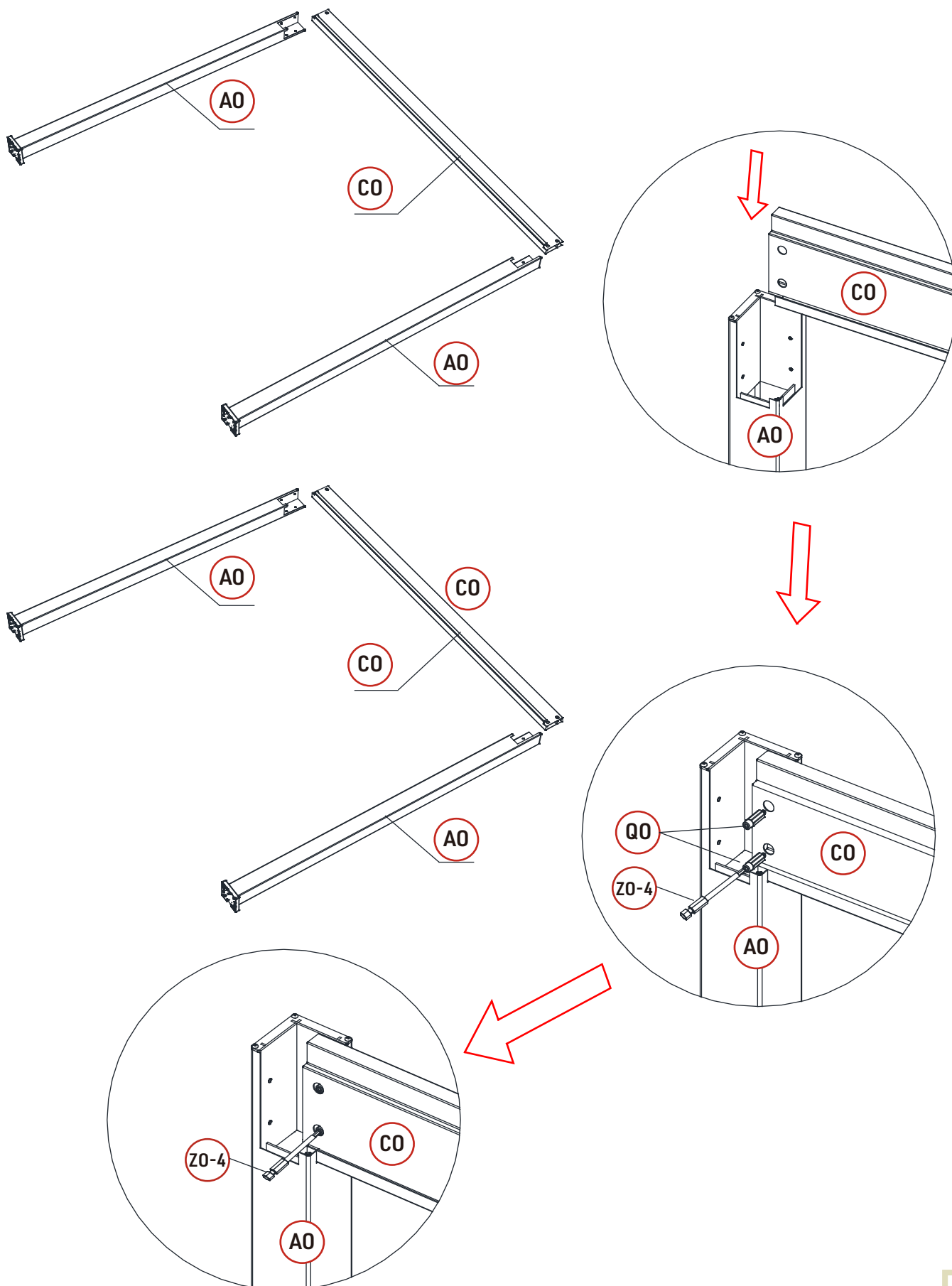

Utilizando 2/3 personas (una sujetando la estructura, otra instalando y otra ayudando en la instalación), añade las vigas **BO-1** y **BO-2** a los postes **AO** y **AO-1** como se muestra en el diagrama. A continuación, fíjalos con los tornillos **QO** utilizando un destornillador y la punta **ZO-4** o la llave Allen **ZO-3**.

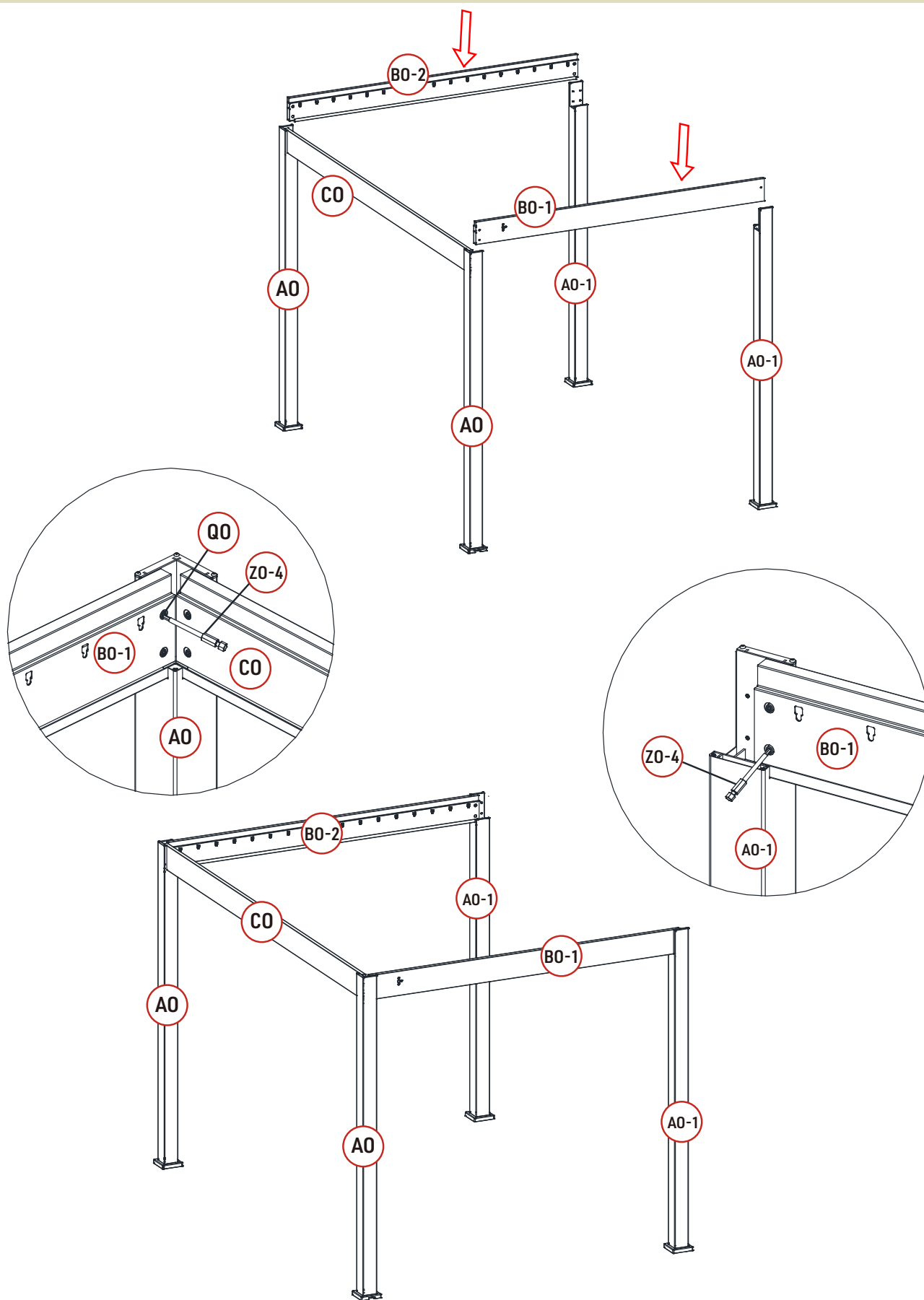

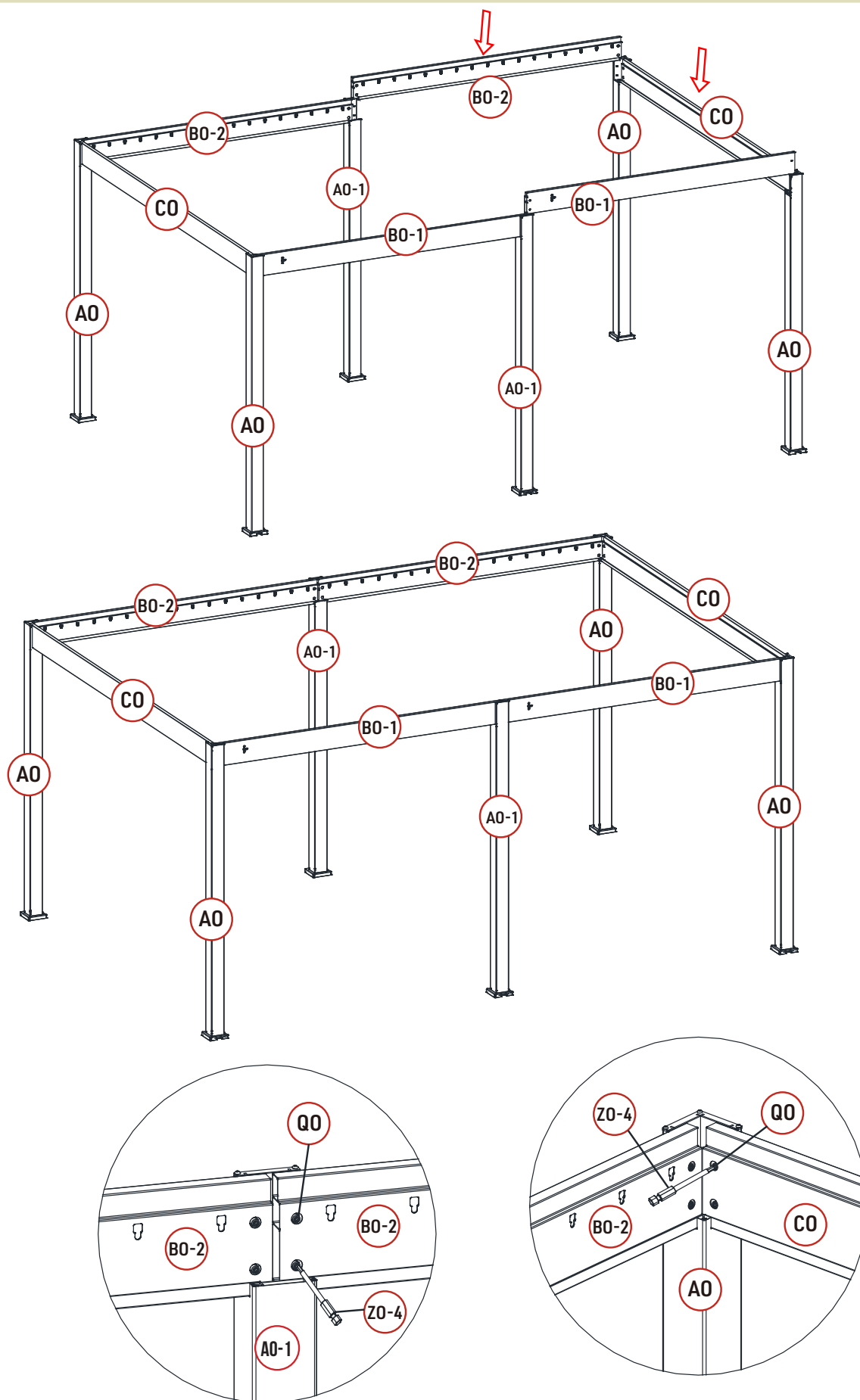

Cierra la estructura como se muestra en el diagrama, formando la segunda parte de la pérgola con las vigas **BO-1** y **BO-2**. Sujétalas a los postes **AO**. Fíjalas a los postes **AO** por un lado y a los postes **AO-1** por el otro con los tornillos **QO**, utilizando un destornillador y la punta **ZO-4** o la llave Allen **ZO-3**.

Fija las patas de conexión **QO-1** en el sentido correcto a los extremos de la viga central **EO** con los tornillos **WO**.

Coloca y calce la viga central **EO** en el centro del marco sobre los postes **AO-1**, a continuación utilizando un destornillador eléctrico y la punta **ZO-7** Fija las patas de conexión **QO-1** en las vigas **BO-1** y **BO-2** con la tornillo autoperforante **WO-1**, como se muestra en el diagrama.

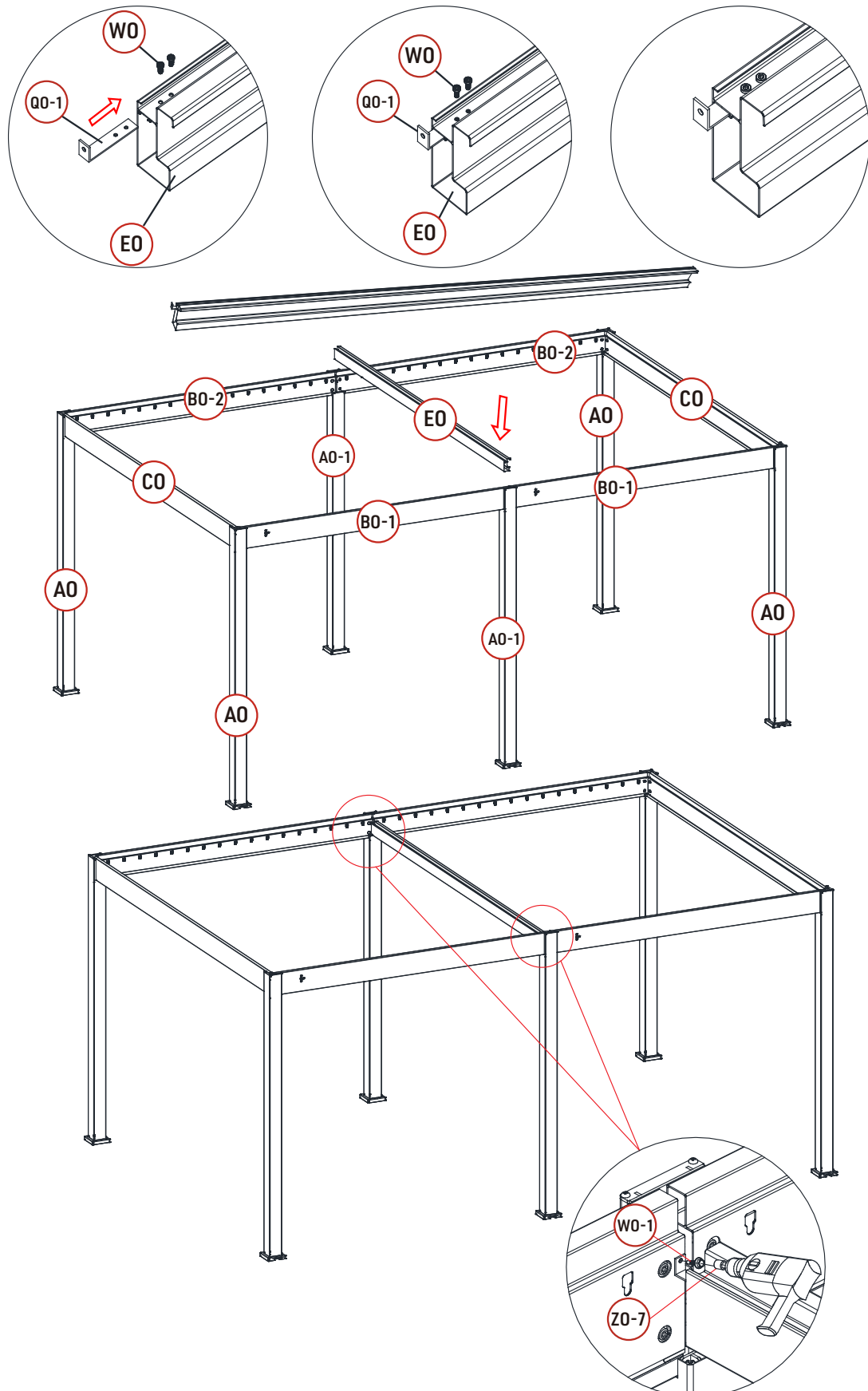

Confecciona y fija el pasador correspondiente al conjunto **XO**, **MO** y **UO** en las tapas de las lamas **LO** y **LO-1**. Asegúrate de que el pasador está instalado en la dirección correcta tanto para la pieza **LO** como para la **LO-1**, tal y como se muestra en el diagrama.

Utiliza un destornillador y la punta **ZO-2** para ayudar a insertar el perno **XO** en la tuerca **UO**. Para evitar lesiones y facilitar al máximo la operación, recomendamos sujetar la tuerca con la llave **ZO-5** durante la misma.

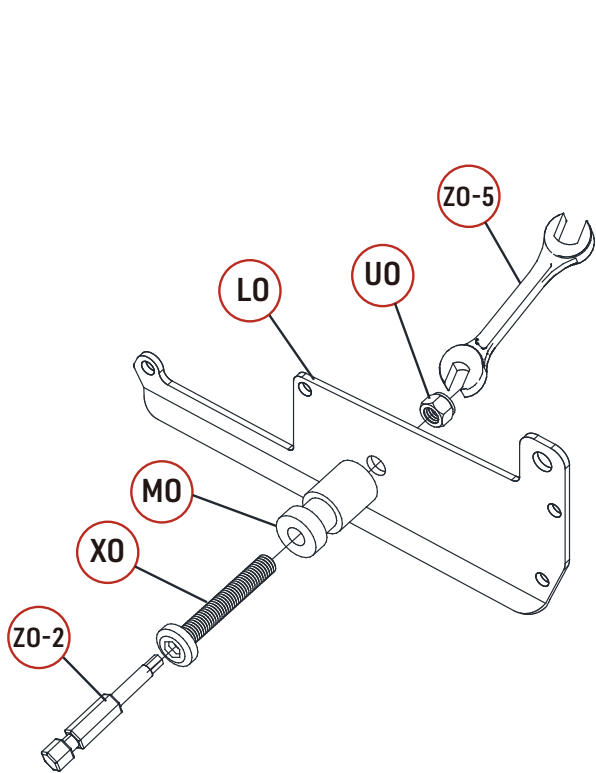

X36

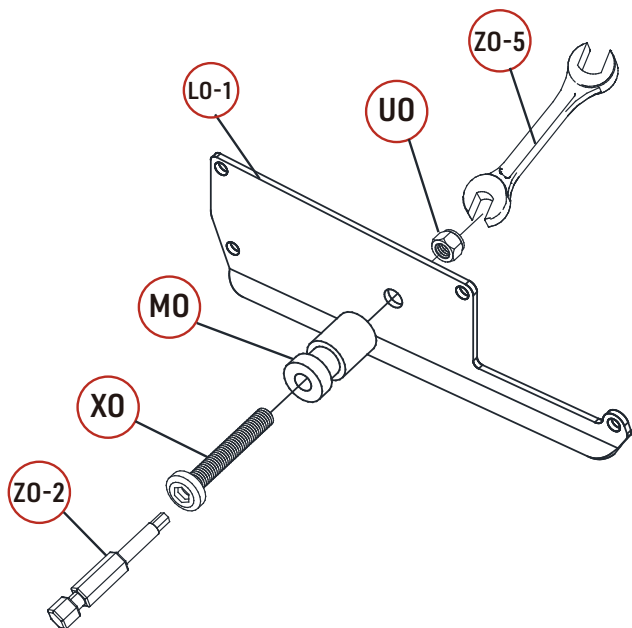

X38

Coloca la lama principal **GO** en la dirección correcta como se muestra en el diagrama, luego fija la tapa de la lama principal **KO** a la derecha de la lama y **LO-1** a la izquierda, con los tornillos **WO** utilizando un destornillador y la punta T20 **ZO-6**.

X2

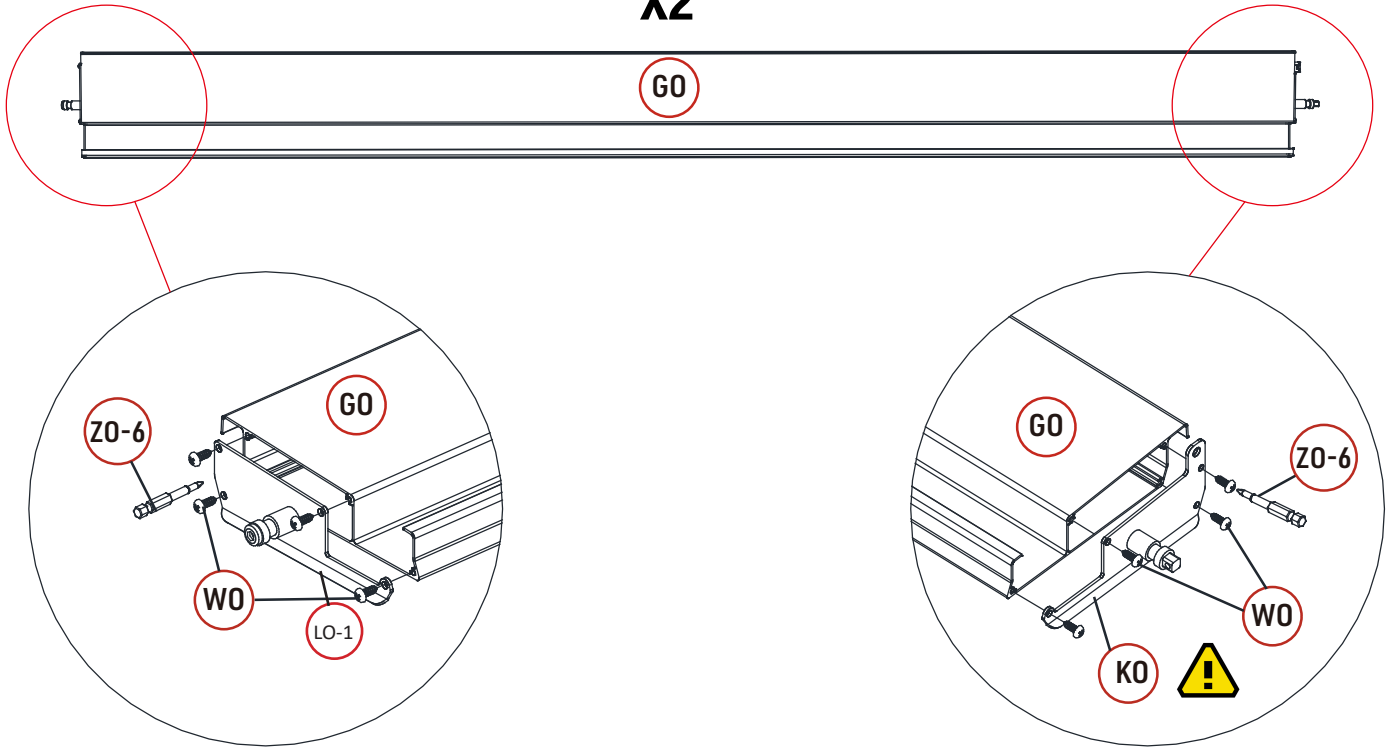

Repite la misma operación con las otras lamas **GO**, fijando las tapas de la lama **LO-1** a la izquierda y **LO** a la derecha.

X36

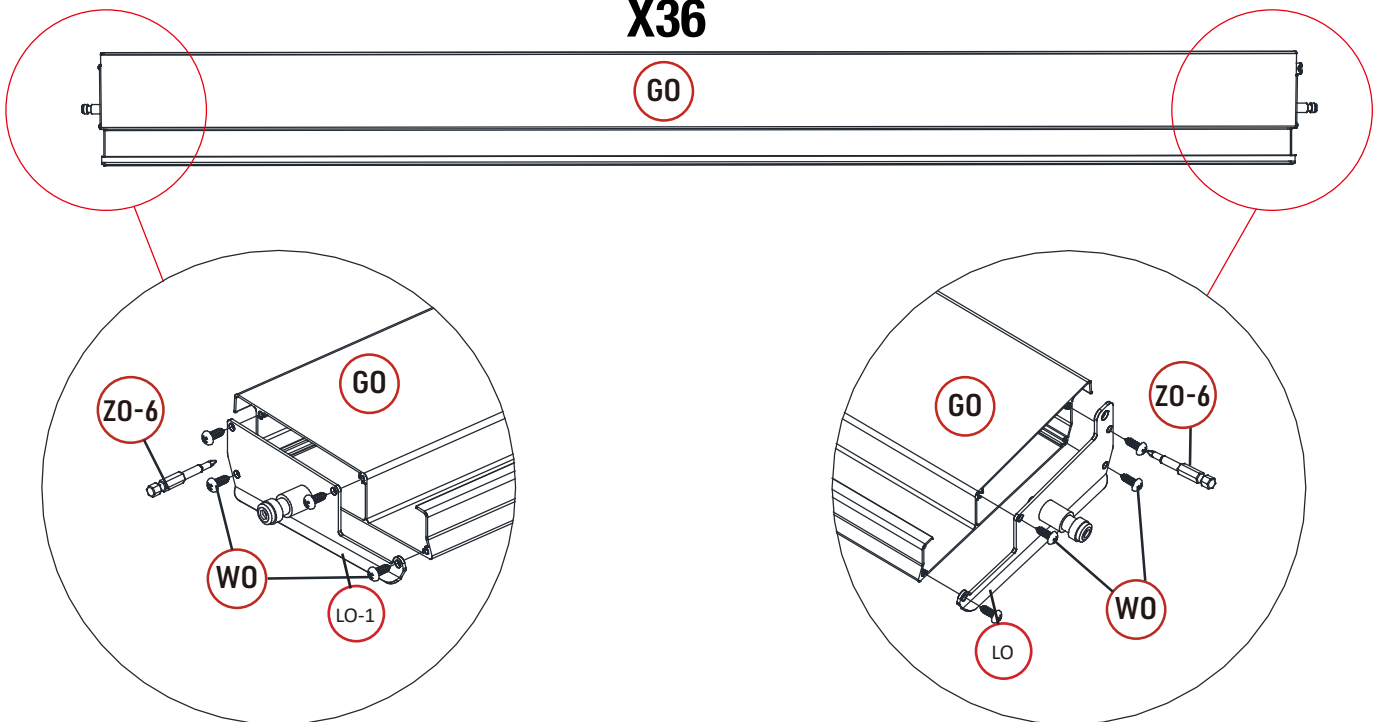

Instala la lama principal en la segunda posición del lugar previsto en la pérgola, empezando por el lado de la manivela para formar el techo.

A continuación, repite la operación para la segunda parte de la pérgola

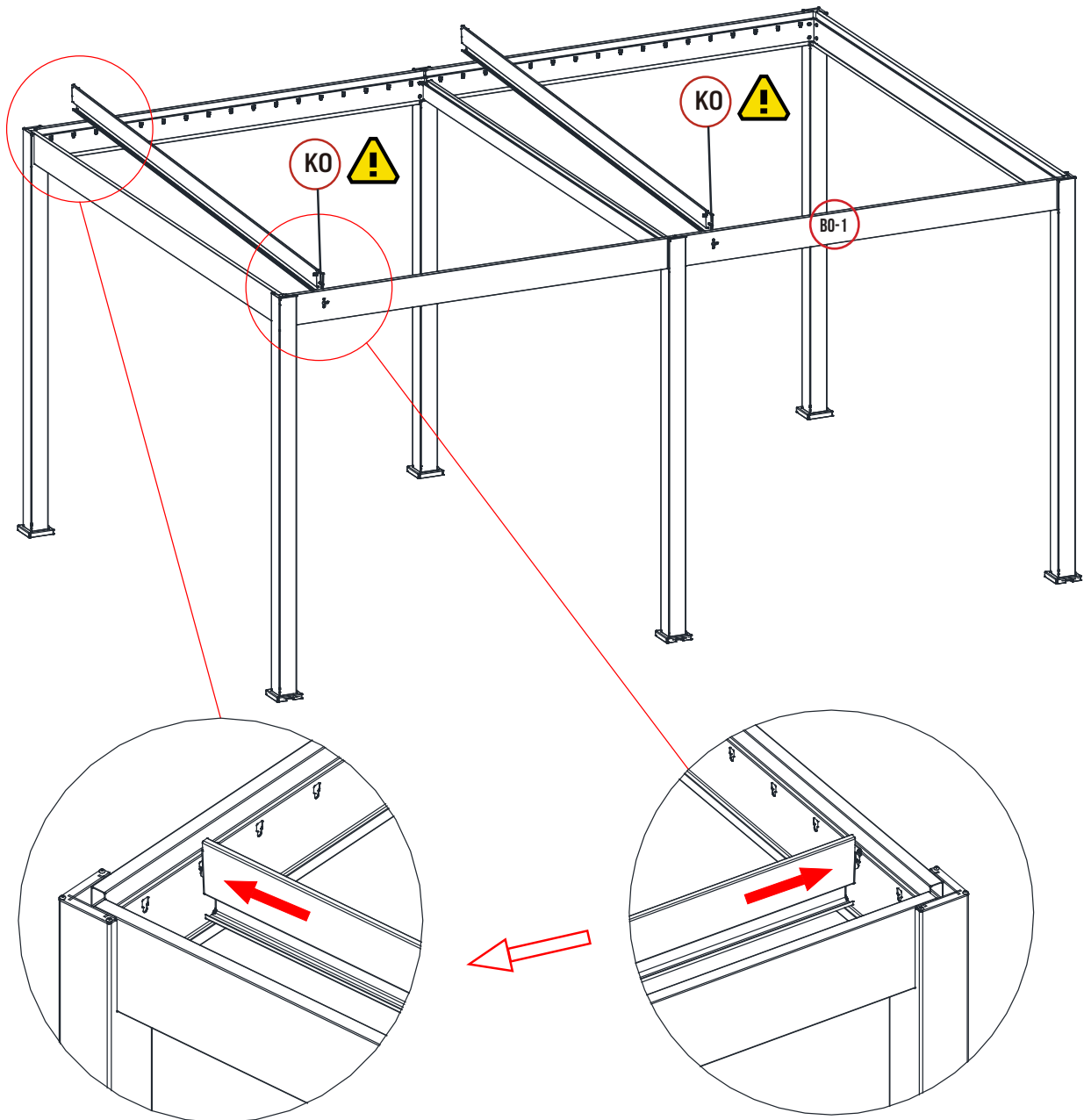

Introduce el cilindro **PO** a través de la viga como se indica en el diagrama, luego empuja hasta que encaje con el pasador de la lama principal **KO**.

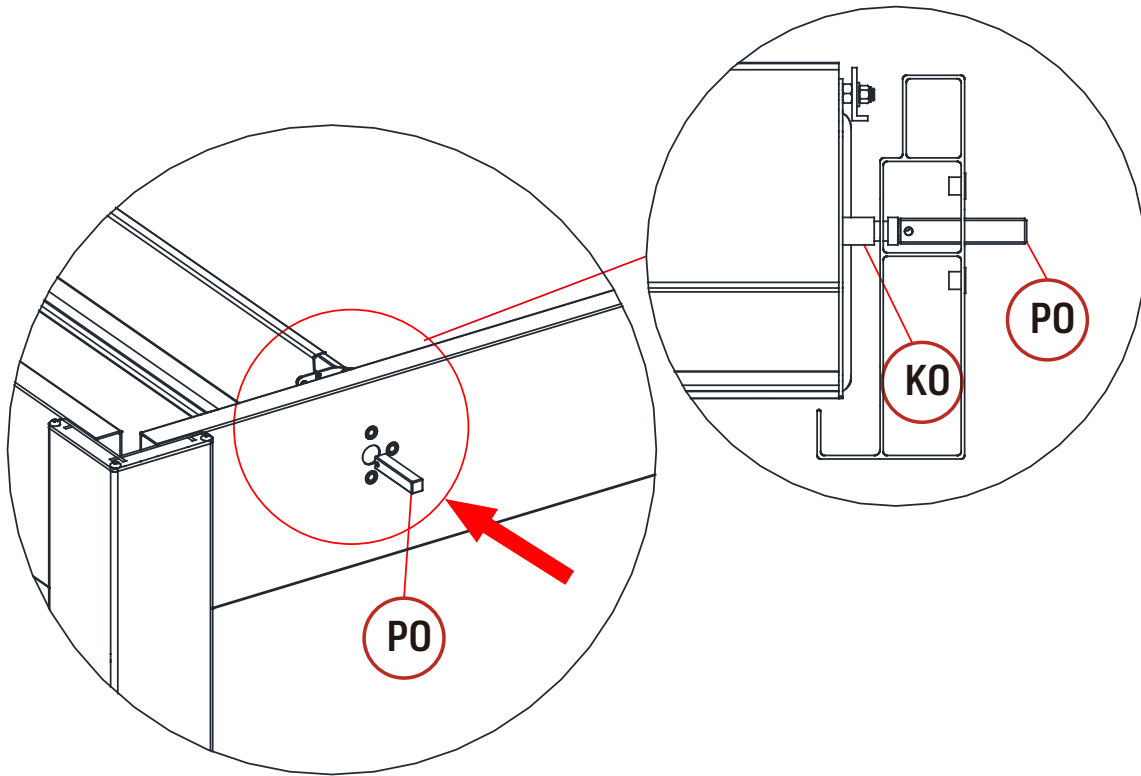

Empareja y atornilla la primera parte de la caja **OO** con el engranaje **NO** a la viga principal **BO-1**, con los 3 tornillos **YO**, utilizando la llave Allen **ZO-3** o un destornillador y la punta **ZO-4**.

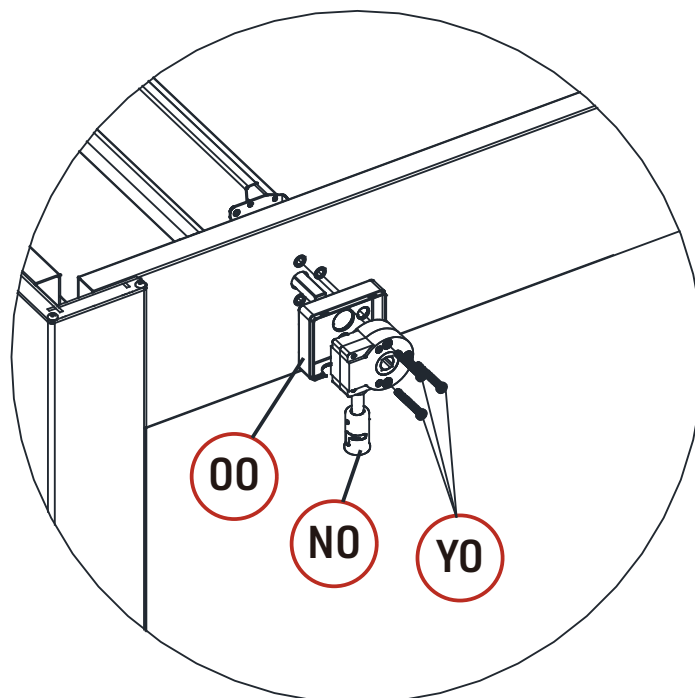

A continuación, repite la operación para la segunda parte de la pérgola

Asegúrese de que el mecanismo manual funciona correctamente girando la lama hacia la derecha y luego hacia la izquierda con la manivela **HO**.

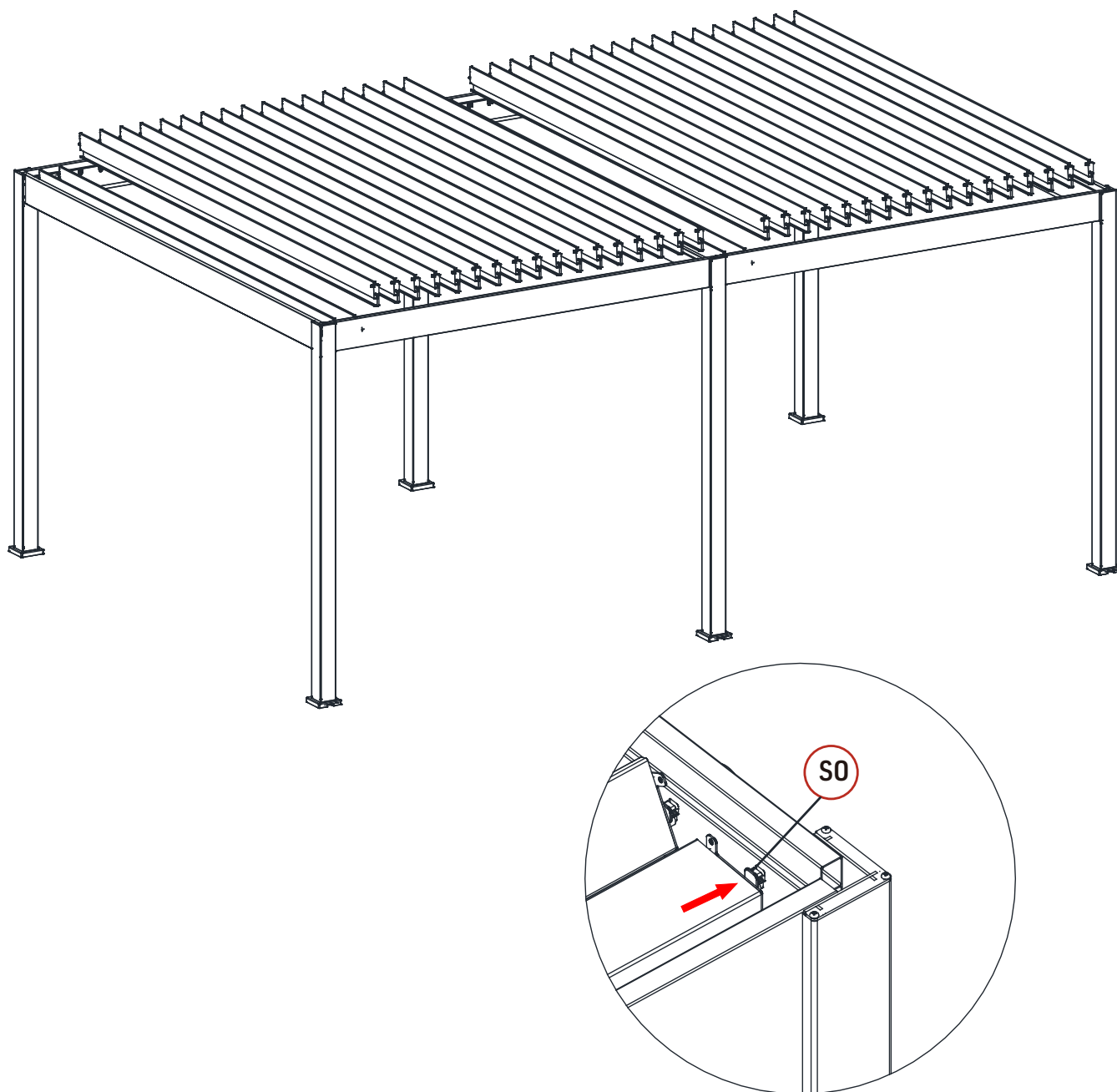

Coloque la lama en posición vertical, para poder instalar las demás lamas una tras otra. A continuación, introduce las cuñas de media luna **SO** como se indica en el diagrama. La abertura de la media luna debe estar en la parte inferior de la cuña.

Repita la operación para la segunda parte de la pérgola.

Fija los tornillos y pernos **XO-2**, **VO** y **UO-1** en cada tapa de la lama, como se indica en el diagrama.

A continuación, fija la barra de conexión **FO** en cada lama con las arandelas **VO** y la tuerca **UO** como se muestra, utilizando un destornillador y con la punta T20 **ZO-6** y la llave **ZO-5** para asegurar la tuerca.

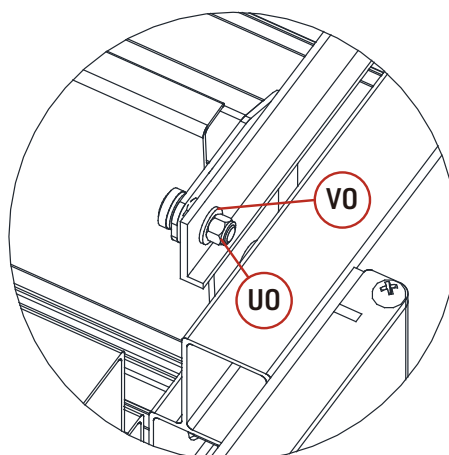
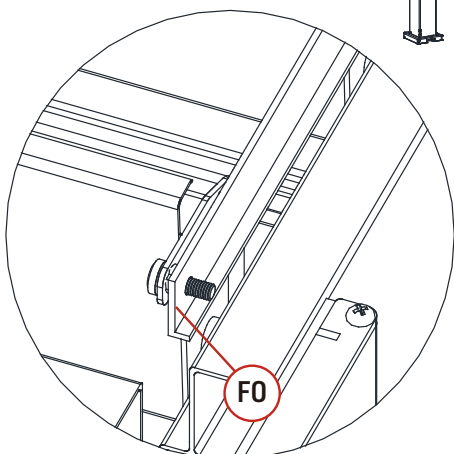
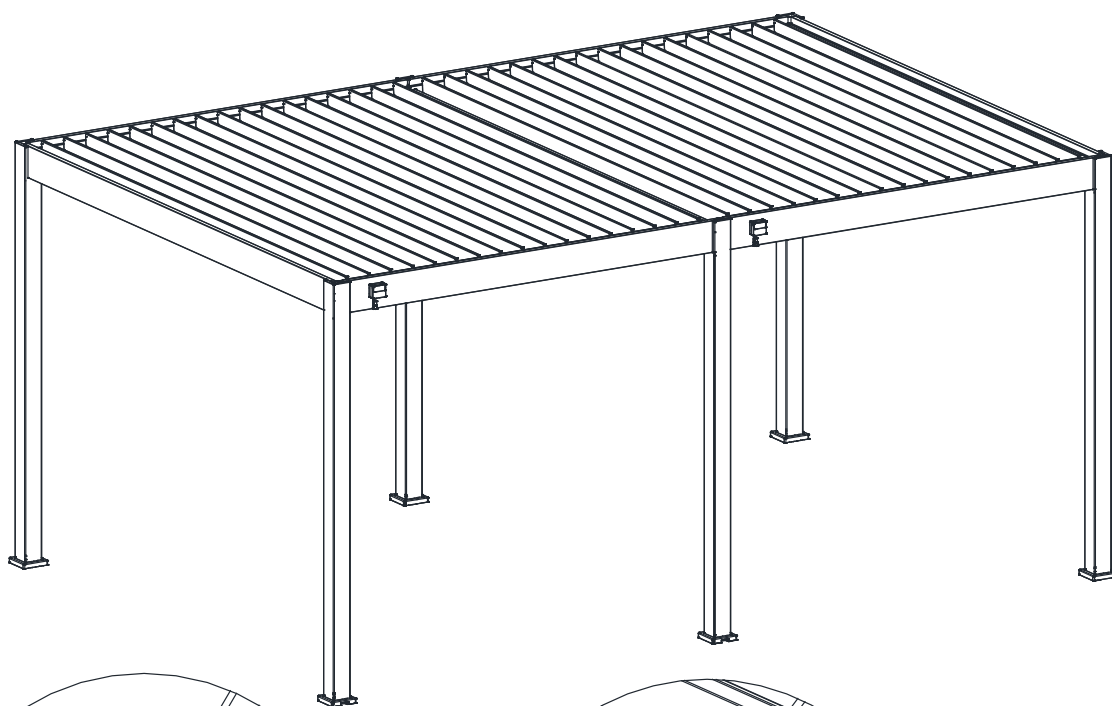
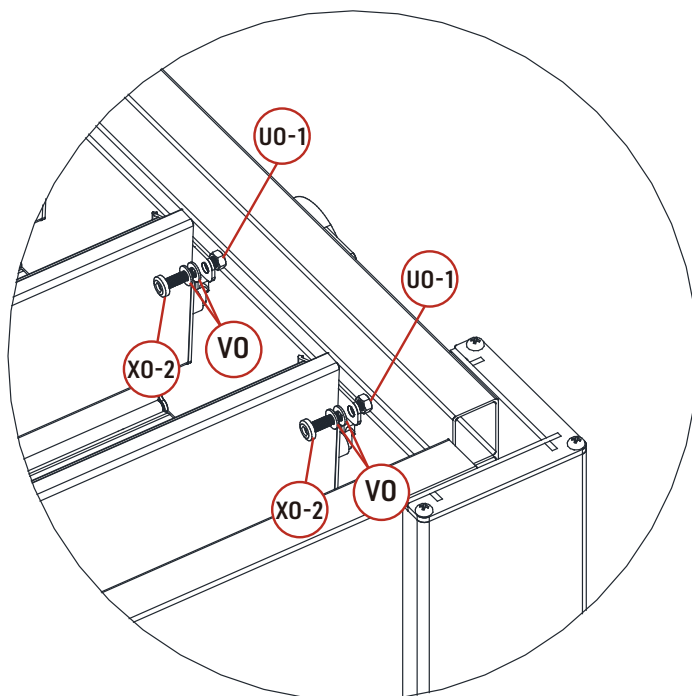
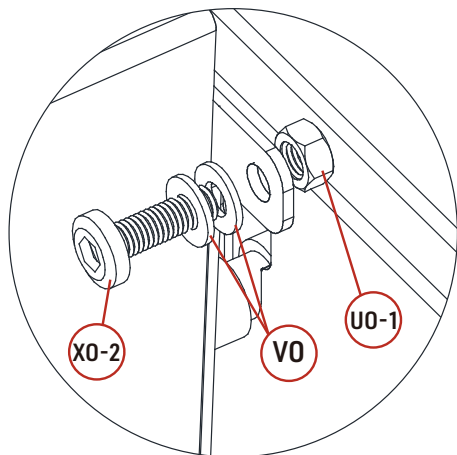

Inserta los botones de acabado **RO** para tapar los huecos que se encuentran en las esquinas del marco como se muestra en el dibujo.

A continuación, engancha la segunda parte de la caja **OO** para cerrar la pieza.

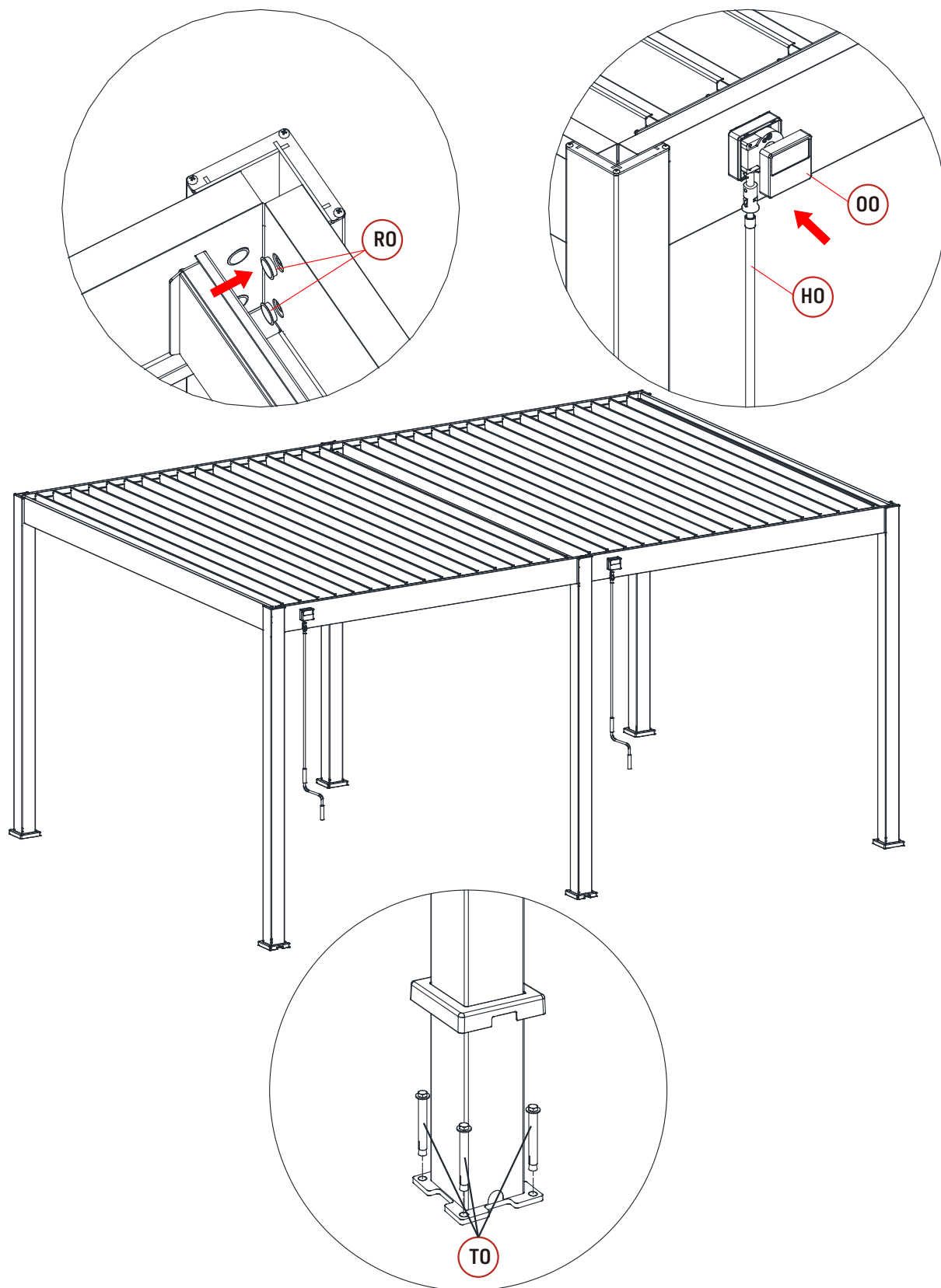

Para terminar, fija la pérgola a un suelo de hormigón duro y plano, utilizando tacos de expansión **TO** y una broca de 12 mm (no suministrada).

Pergola bioclimatica autoportante 4x6M

Antracite : 15-728783 / Bianco : 15-728868 / Antracite e Bianco : 15-728943

Istruzioni da conservare durante tutta la durata di vita del prodotto.

Vi chiediamo di leggere attentamente le istruzioni prima di procedere al montaggio.

L'utilizzatore sarà responsabile dei danni o infortuni causati da un utilizzo non conforme.

1. PRECAUZIONI D'UTILIZZO

Questo prodotto non deve essere utilizzato in caso di forti intemperie: temporali, venti violenti, grandine. Garantiamo la resistenza della pergola per dei venti fino a 100 km/h e un peso di neve fino a 50kg/m².

In caso di forti venti o nevicate, si consiglia vivamente di lasciare le lamelle aperte. In caso di dimenticanza, dovrete sgomberare la neve dalla pergola onde evitare un sovraccarico importante sulle lamelle.

La nostra pergola può sopportare le piogge forti, ma, non vi possiamo garantire un'impermeabilità al 100%.

Nel caso di episodi climatici eccezionali, l'impermeabilità può essere compromessa. Non lasciate i prodotti sensibili all'umidità sotto la pergola. Non montare sul tetto né sulla struttura della pergola.

2. CONSIGLI DI MONTAGGIO

A seconda dell'ubicazione e della superficie, le costruzioni possono essere soggette a dichiarazioni di lavori o a richieste di permessi di costruzione. Vi invitiamo a contattare il vostro municipio per ottenere le informazioni necessarie prima dell'installazione.

Montaggio del prodotto:

- 2 a 3 persone sono necessarie
- Togliere la pellicola di protezione
- Non lasciare i bambini giocare a prossimità della zona di montaggio
- Attenzione ai rischi di schiacciamento
- Mai stringere completamente le viti prima di aver assemblato tutta la parte interessata
- Tutte le fasi di assemblaggio devono essere eseguite con attenzione
- Controllare i livelli, le diagonali e l'equilibrio della struttura
- Fissare la pergola solo dopo averla montata

Nessuna modifica può essere apportata al prodotto. I prodotti modificati dall'utilizzatore non sono più coperti dalla garanzia del fabbricante.

Il luogo di ubicazione deve essere scelto in maniera appropriata. Si raccomanda di evitare di montare la pergola di fronte ai venti dominanti e sotto un albero.

La pergola dev'essere montata su una base adeguata, stabile e livellata, si consiglia di installarla su una lastra di cemento o su dei blocchi di cemento ad ogni palo. Vi chiediamo di ancorare correttamente la pergola al suolo utilizzando i pezzi W.

Se desiderate posizionare la vostra pergola a ridosso della vostra casa o di un'abitazione, vi chiediamo di controllare la presenza di grondaie per lo scorrimento dell'acqua. La pergola Ombréa® non potrà sopportare e garantire un'impermeabilità perfetta se le acque piovane della vostra abitazione defluiscono sopra.

In caso di non rispetto delle raccomandazioni di montaggio, la garanzia non potrà applicarsi.

3. MANUTENZIONE DELLA PERGOLA

Una manutenzione periodica è necessaria per assicurare la longevità e l'aspetto estetico, vi raccomandiamo di:

- Lavare la vostra pergola 1 a 2 volte all'anno con dell'acqua dolce e una spugna o un panno. Non utilizzare prodotti corrosivi o un supporto abrasivo.
- Controllare regolarmente il serraggio delle viti (almeno 1 volta all'anno)
- Oliare i pezzi di ferramenta (almeno 1 volta all'anno)
- Assicurarsi che il flusso dell'acqua delle grondaie non sia ostruito (foglie, rami, ecc.)
- Togliere l'acqua che potrebbe stagnare attorno ai piedi della pergola (sollevare le protezioni)

4. GARANZIA

Ombréa® garantisce la disponibilità dei pezzi di ricambio per 2 o 5 anni (a seconda del prodotto). La garanzia si applica solo se le istruzioni di stoccaggio, montaggio, utilizzo, manutenzione vengono rispettate.

La garanzia non copre:

- L'usura normale inerente ai prodotti.
- La perdita o il danno di qualsiasi pezzo durante il disimballaggio o l'installazione.
- La mancanza di manutenzione ragionevole, la negligenza, il vandalismo, l'impatto con degli oggetti esterni, l'uso della forza, il contatto con degli abrasivi, l'estetismo, lo smontaggio, la ricostruzione o la rilocalizzazione.
- Casi di forza maggiore: grandine, venti forti, tempeste, neve, inondazioni, fulmine...
- Prodotto modificato dall'utilizzatore.

La garanzia comprende soltanto la sostituzione del pezzo di ricambio o del prodotto fornito, esclude le spese, costi e indennità di qualsiasi tipo.

Qualsiasi richiesta di garanzia deve essere effettuata presso il punto vendita (negoziario o sito internet) dove è stato comprato il prodotto.

5. ELENCO DELLE PARTI (PER CARTONE)



Prima di procedere al montaggio della vostra pergola bioclimatica, è necessario controllare che tutte le parti siano presenti e non siano danneggiate.

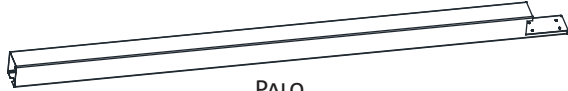

Eventuali parti mancanti devono essere segnalate entro i 10 giorni dall'acquisto. Questo può essere fatto attraverso il vostro rivenditore o direttamente facendo una richiesta sul nostro sito sav.comintes.com.

Non buttare l'imballaggio senza assicurarsi del corretto funzionamento della pergola.

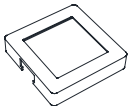
COLLO 1/6 (PALI E FERRAMENTA)

Riferimento	Schema	Quantità
AO	 PALO	4
AO-1	 PALO	2

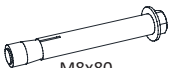

Riferimento	Schema	Quantità
IO	 COPERCHIO PIASTRA	6
JO	 PIASTRA DI ANCORAGGIO	6

Riferimento	Schema	Quantità
TO	 M8x80 TASSELLO PER CEMENTO M80x80	24
XO-1	 6x35 BULLONE 6x35	24

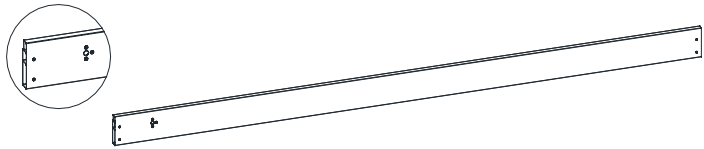
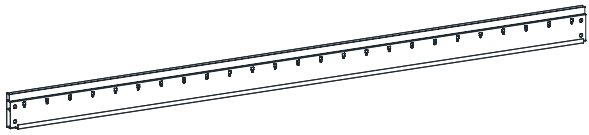
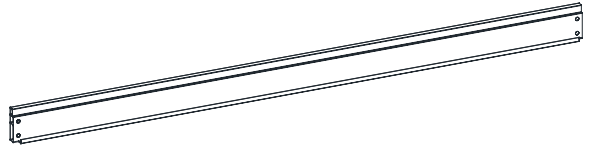

COLLO 2/6 (TRAVI E FERRAMENTA)

Riferimento	Schema	Quantità
BO-1	 TRAVE PRINCIPALE	2
BO-2	 TRAVE POSTERIORE	2
CO	 TRAVE LATERALE	2

COLLO 2/6 (TRAVI E FERRAMENTA)

Riferimento	Schema	Quantità
EO	 TRAVE CENTRALE	1
FO	 BARRA DI CONNESSIONE	2
HO	 MANOVELLA	2



Riferimento	Schema	Quantità
NO	 GEARBOX	2
OO	 SCATOLA	2
PO	 CILINDRO	2
QO	 VITI DI FISSAGGIO DELLA TRAVE	24
QO-1	 PIASTRA DI GIUNZIONE	2
RO	 TAPPO DI FINITURA	24
SO	 CUNEO A MEZZALUNA	76
UO	 DADO	114
UO-1	 DADO IN PLASTICA	76
VO	 RONDELLA	114

Riferimento	Schema	Quantità
XO	 6x40 BULLONE 6X40	74
XO-2	 6x20 BULLONE 6X20	38
YO	 6x45 BULLONE 6X45	6
ZO-1	 CHIAVE ALLEN DA 4 MM	1
ZO-2	 PUNTA DI CACCIAVITE 4 MM	1
ZO-3	 CHIAVE ALLEN DA 6 MM	1
ZO-4	 PUNTA DI CACCIAVITE DA 6MM	1
ZO-5	 CHIAVE PIATTA 10 MM	1
ZO-6	 PUNTA DI CACCIAVITE T20	1
ZO-7	 PUNTA DI CACCIAVITE	1

COLLO 3/6 (LAMELLE E FERRAMENTA)

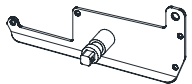
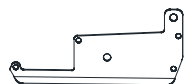
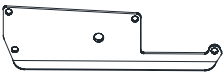
Riferimento	Schema	Quantità
GO	 LAMA	8

Riferimento	Schema	Quantità
KO	 COPRI-LAMELLA PRINCIPALE	2
LO	 COPRI-LAMELLA A	36
LO-1	 COPRI-LAMELLA B	38

Riferimento	Schema	Quantità
MO	 PERNO	74
WO	 4x16 VITI 4x16	308
WO-1	 5x19 VITE AUTOFILETTANTE	2

COLLO 4/6, 5/6 E 6/6 (LAMELLE)

Riferimento	Schema	Quantità
GO	 LAMA	10

Le parti in alluminio sono le seguenti: AO, AO-1, BO-1, BO-2, CO, FO, GO, IO, KO, LO e LO-1.

Le viti e le altre parti sono in acciaio inox, acciaio zincato, plastica o nylon.

Per ulteriori informazioni, consultate le specifiche tecniche del prodotto e la pagina delle FAQ all'indirizzo www.pergola-ombrea.com o contattate il proprio rivenditore.

6. MATERIALE (NON FORNITO) NECESSARIO PER IL MONTAGGIO



Occhiali e guanti protettivi



2 scalette



Trapano a percussione + punta per cemento da 12 mm



Trapano avvitatore

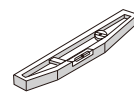

Livella



Taglierino



Elmetto

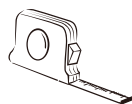

Metro a nastro

7. CONTACTO

Desiderosi di migliorare, non esitate a inviarci i vostri commenti e suggerimenti al seguente indirizzo: contact@pergola-ombrea.com

Saremo lieti di ricevere i vostri migliori scatti della vostra installazione.

Il team Ombréa vi ringrazia per l'acquisto e vi augura giorni felici sotto la vostra pergola!

8. PIANO DI MONTAGGIO (DIMENSIONI IN MM)

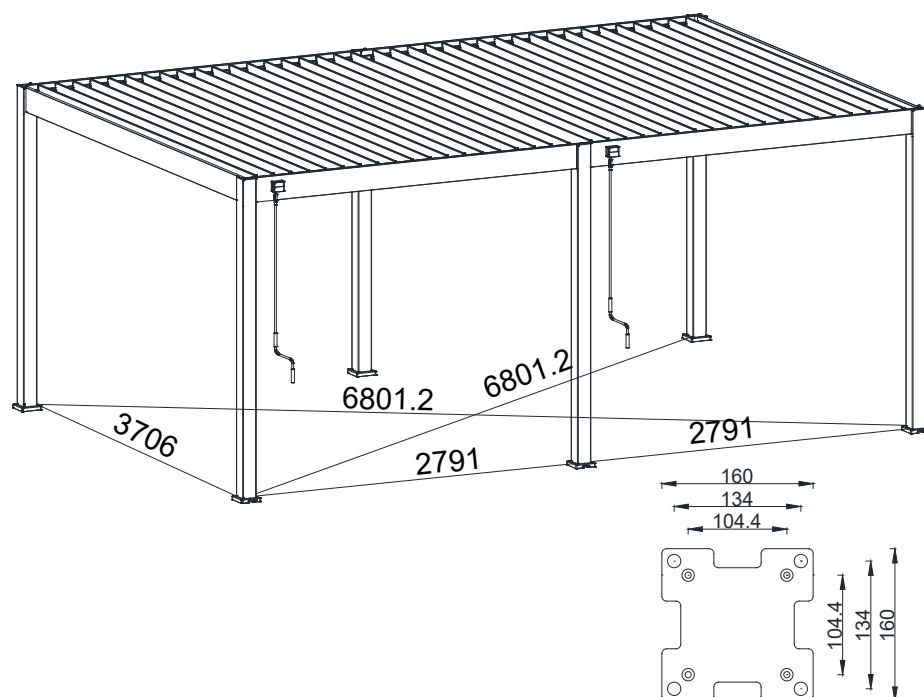
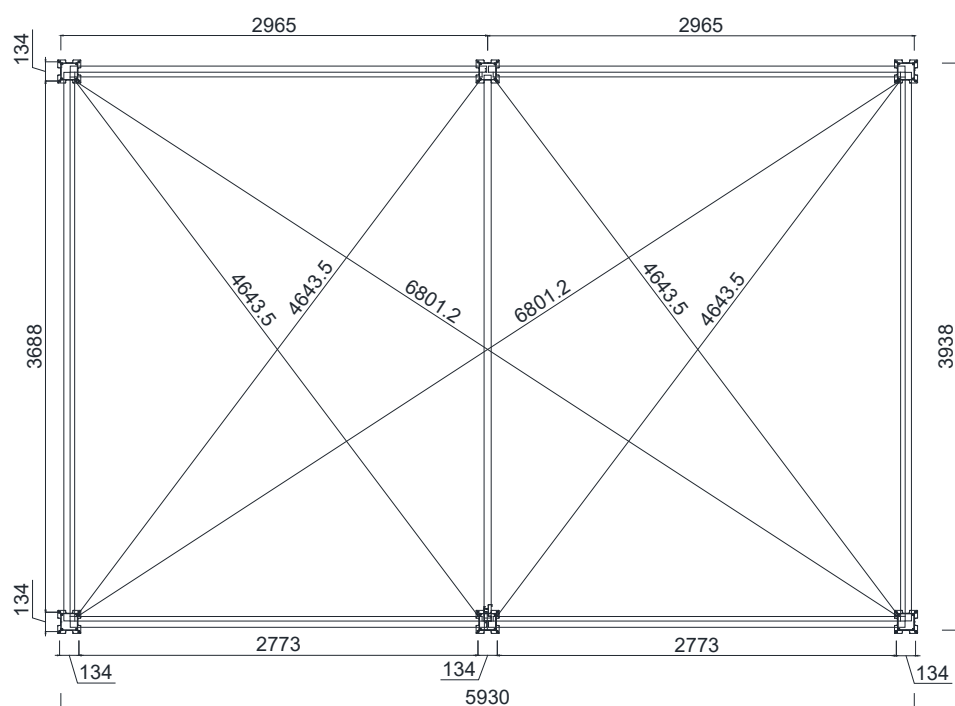

9. TAPPE DEL MONTAGGIO

Per evitare di danneggiare la vostra pergola durante il montaggio, si consiglia di assemblarla su un tavolo, dei cavalletti o una superficie piana e pulita.

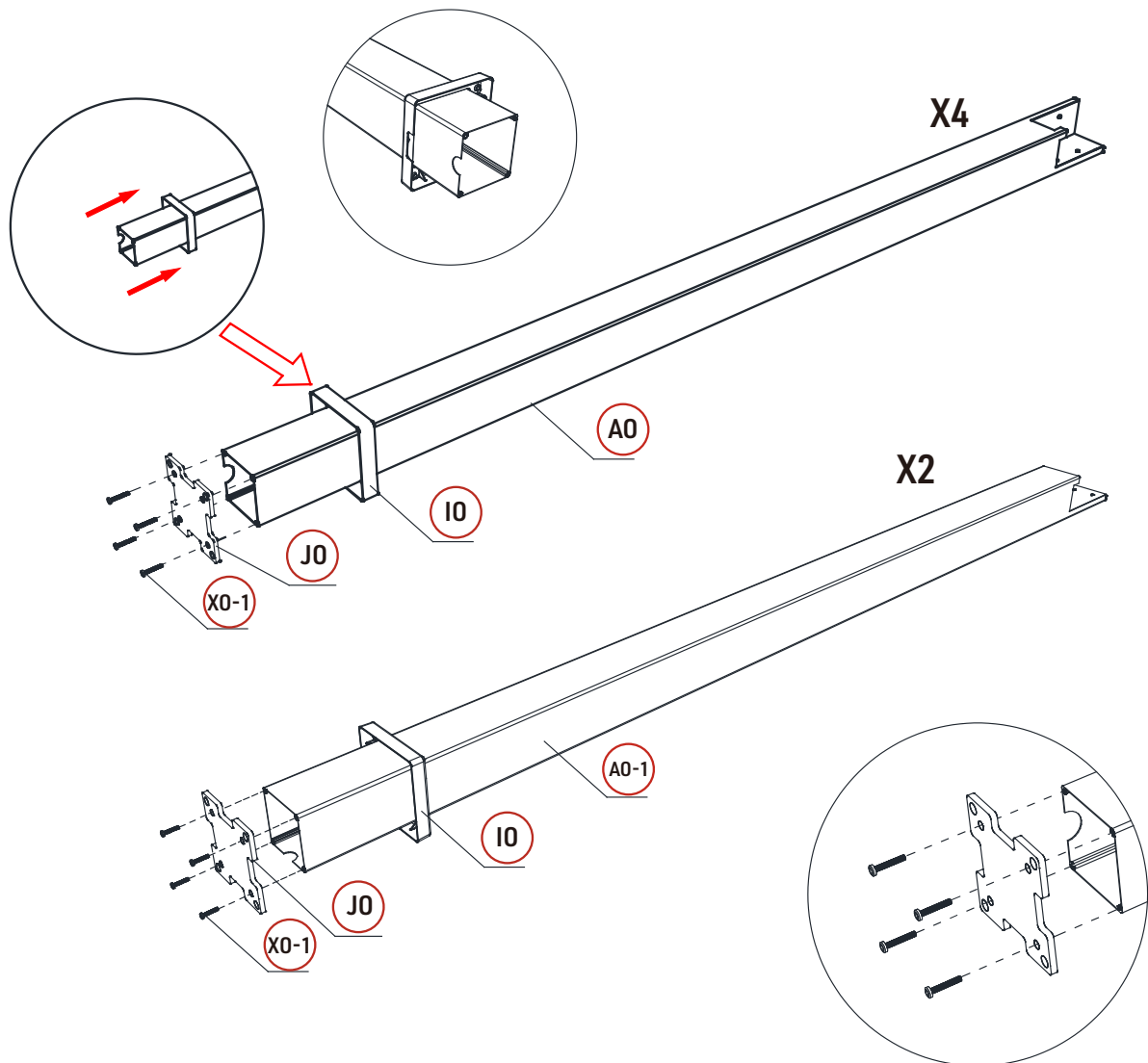

Fate scorrere i coperchi **IO** sui montanti **A0**, posizionando l'apertura nella stessa direzione dell'apertura nel montante a forma di mezzaluna.

Fissare quindi la piastra **JO** con le viti **XO-1** utilizzando l'avvitatore. Iniziate ad avvitare leggermente, completate l'operazione fino in fondo quando tutte le viti sono in posizione.

Posizionate e fissate la trave **BO-1** sui montanti **AO** con le viti **QO** su ciascun lato, utilizzate un avvitatore e una punta **ZO-4** o una chiave Allen **ZO-3**.

Ripetete l'operazione una seconda volta con le stesse parti rimanenti.

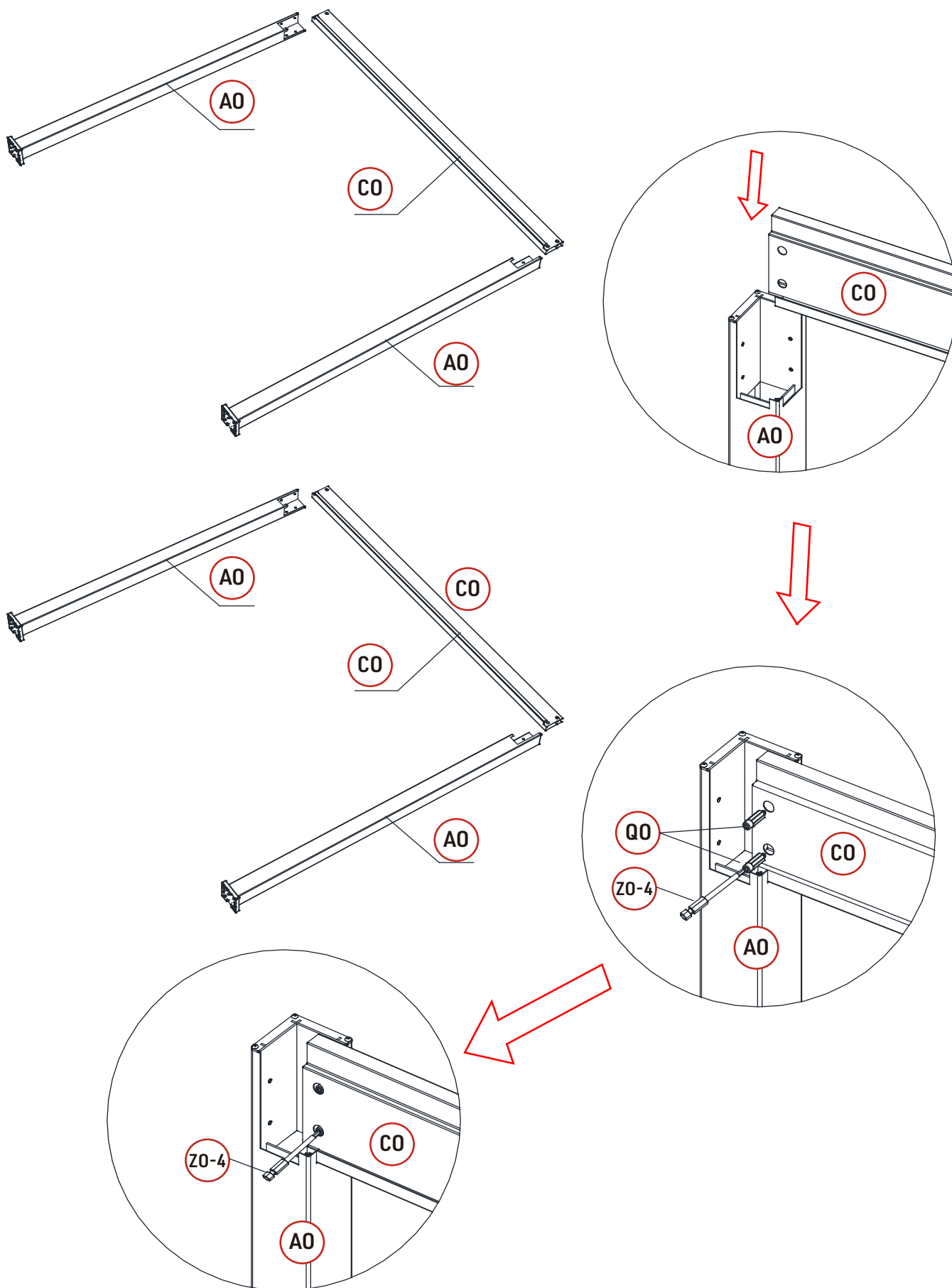

Con l'aiuto di 2/3 persone (una che regge la struttura, una incaricata dell'installazione e una che assiste), aggiungete la prima trave **CO** e avvitatela con le viti **QO** utilizzando un avvitatore e una punta **ZO-4** oppure la chiave Allen **ZO-3**.

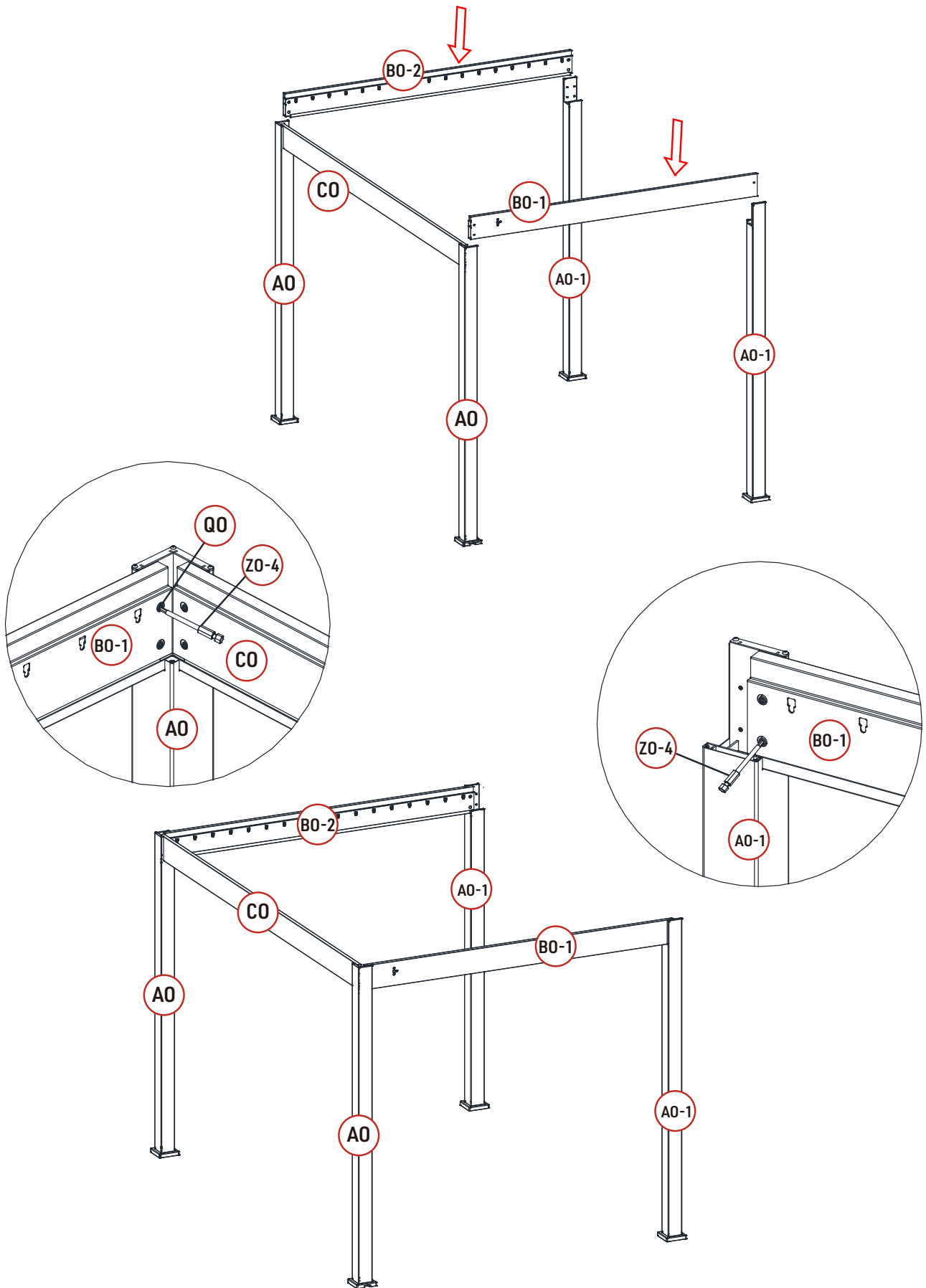

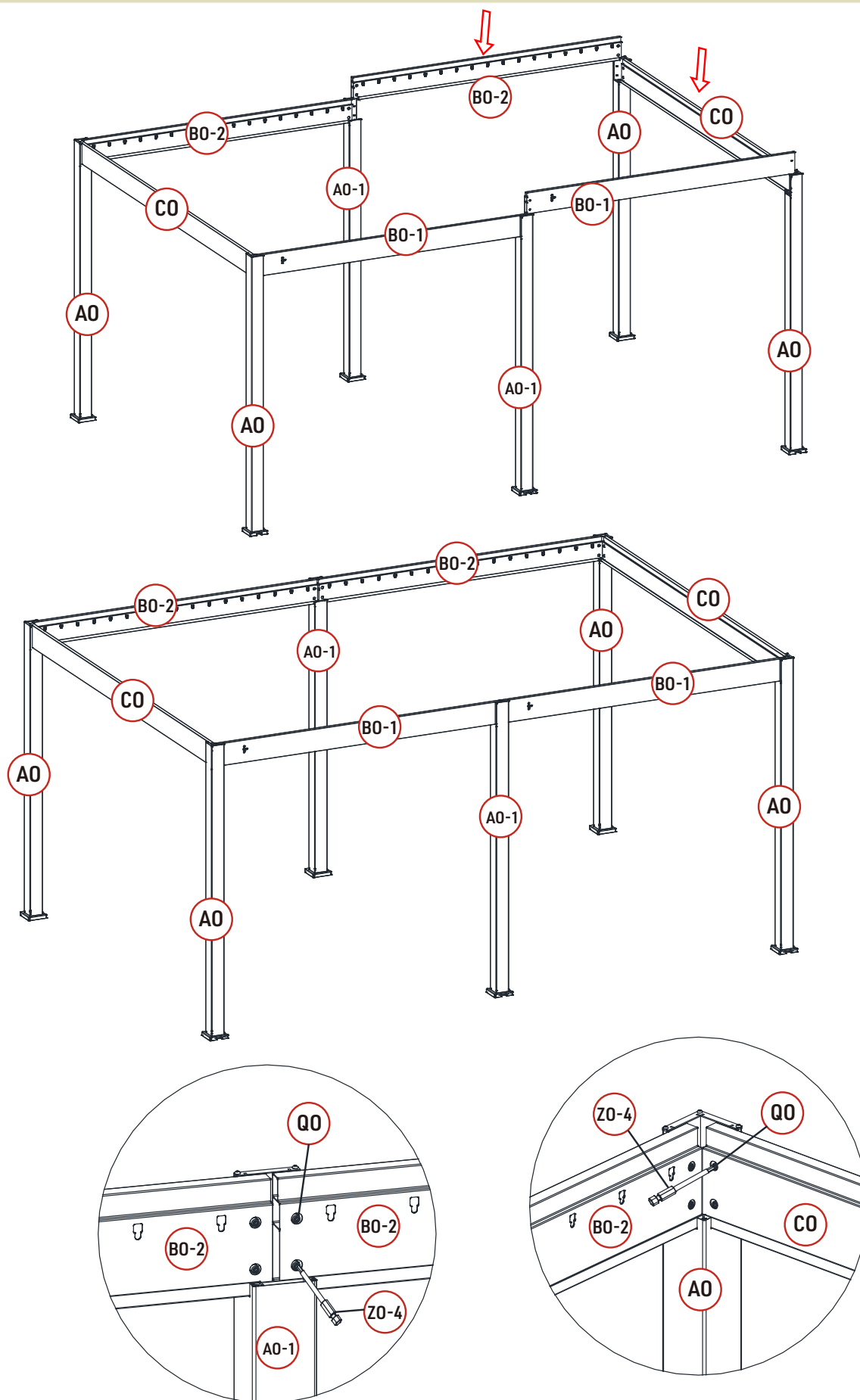

Chiudete la struttura come indicato nello schema, formando la seconda parte della pergola con le travi **BO-1** e **BO-2**. Fissatele da un lato ai montanti **AO** e dall'altro ai montanti **AO-1** con le viti **QO**, utilizzando un avvitatore e la punta **ZO-4** oppure la chiave Allen **ZO-3**.

Fissate le piastre di giunzione **QO-1** nella giusta direzione alle estremità della trave centrale **EO** con le viti **WO**.

Posizionate e spessorate la trave centrale **EO** al centro del telaio sui montanti **AO-1**, quindi con un trapano avvitatore e la punta **ZO-7** fissate le gambe di collegamento **QO-1** alle travi **BO-1** e **BO-2** con la vite autoperforante **WO-1**, come indicato nello schema.

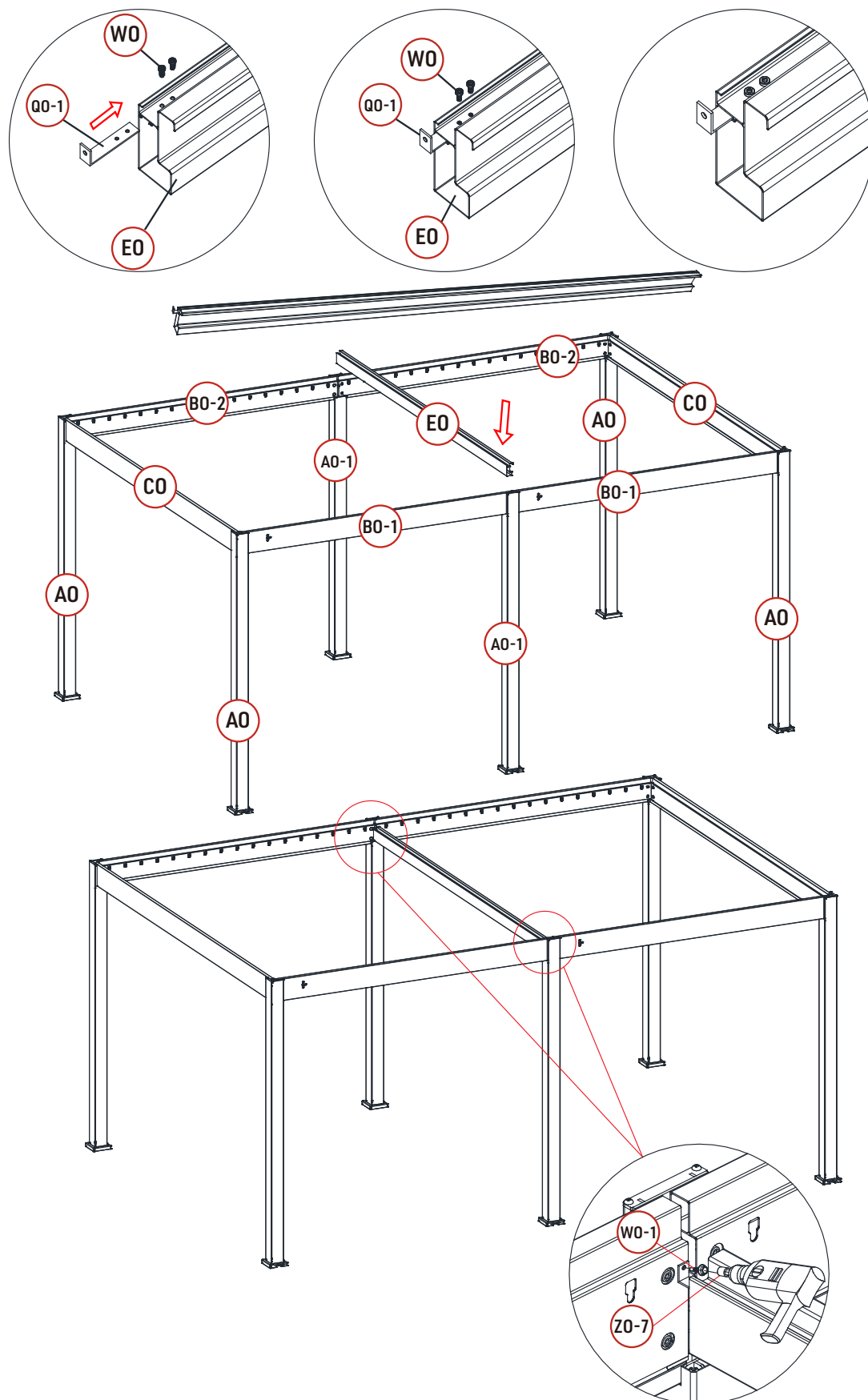

Montate e fissate il perno corrispondente all'insieme delle parti **XO**, **MO** e **UO** nei copri-lamella **LO** e **LO-1**. Assicuratevi che il perno sia installato correttamente nella giusta direzione per la parte **LO** e per la parte **LO-1**, come indicato nello schema.

Utilizzate l'avvitatore e la punta **ZO-2** per inserire il bullone **XO** nel dado **UO**. Per evitare lesioni e rendere l'operazione non troppo difficile, si consiglia di tenere il dado con la chiave **ZO-5** durante questa manipolazione.

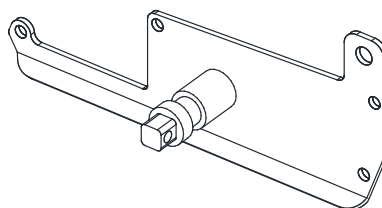
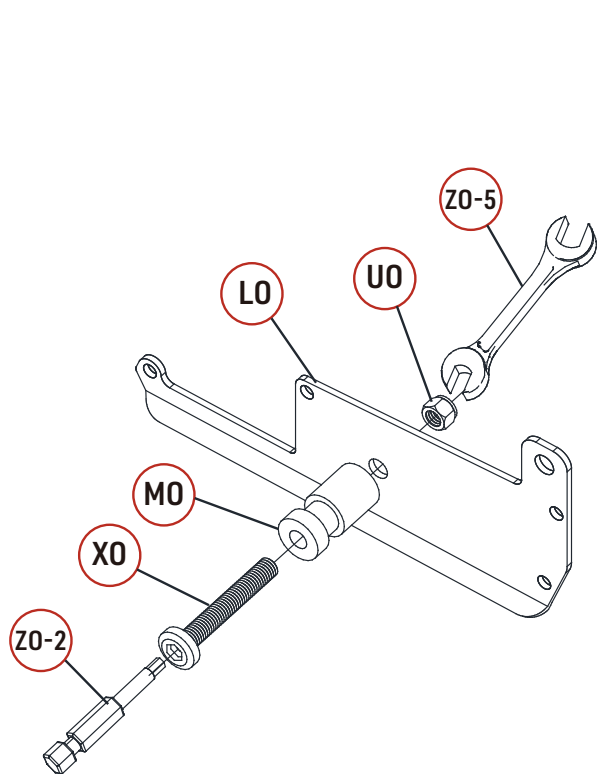

X36

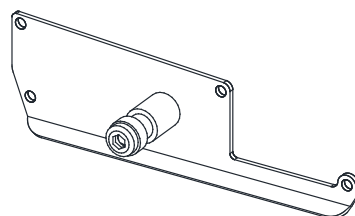
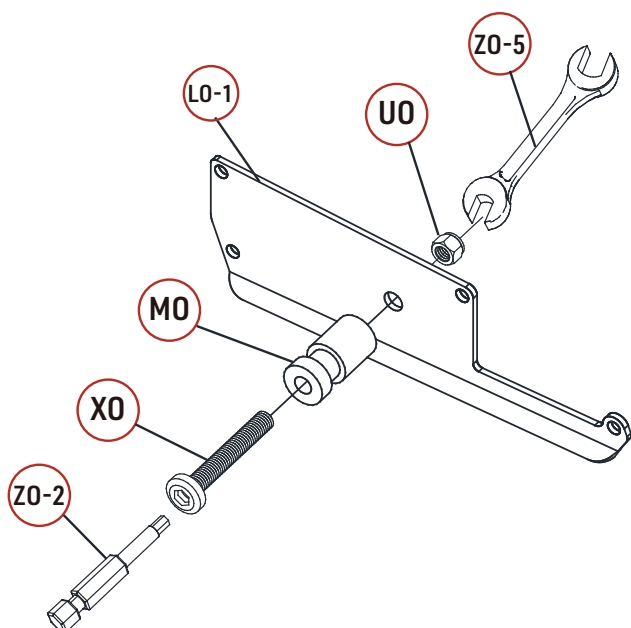

X38

Posizionate la lamella principale **GO** nella direzione corretta, come indicato nello schema, quindi fissate il copri-lamella principale **KO** a destra della lamella e **LO-1** a sinistra, con le viti **WO** grazie all'avvitatore e la punta T20 **ZO-6**.

X2

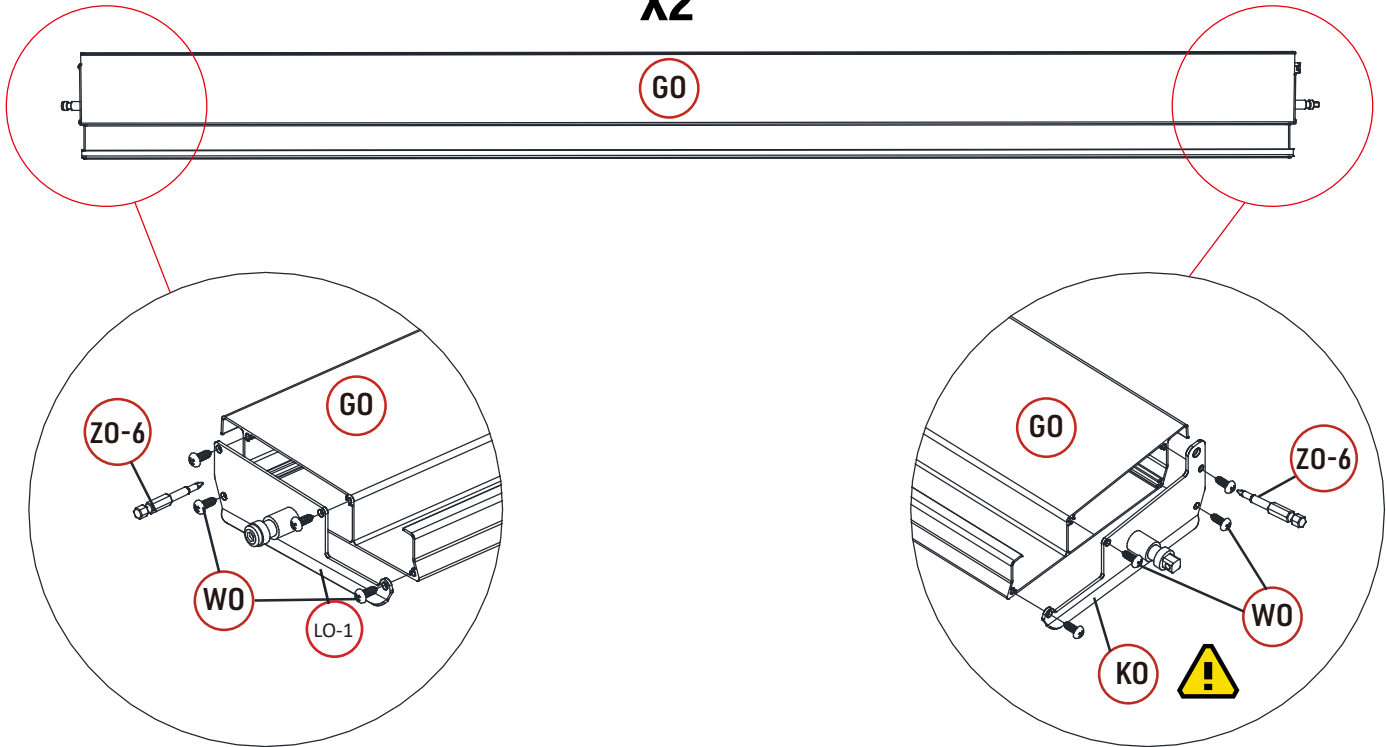

Ripetete la stessa operazione con le altre lamelle **GO**, fissando i copri-lamella **LO-1** a sinistra e **LO** a destra.

X36

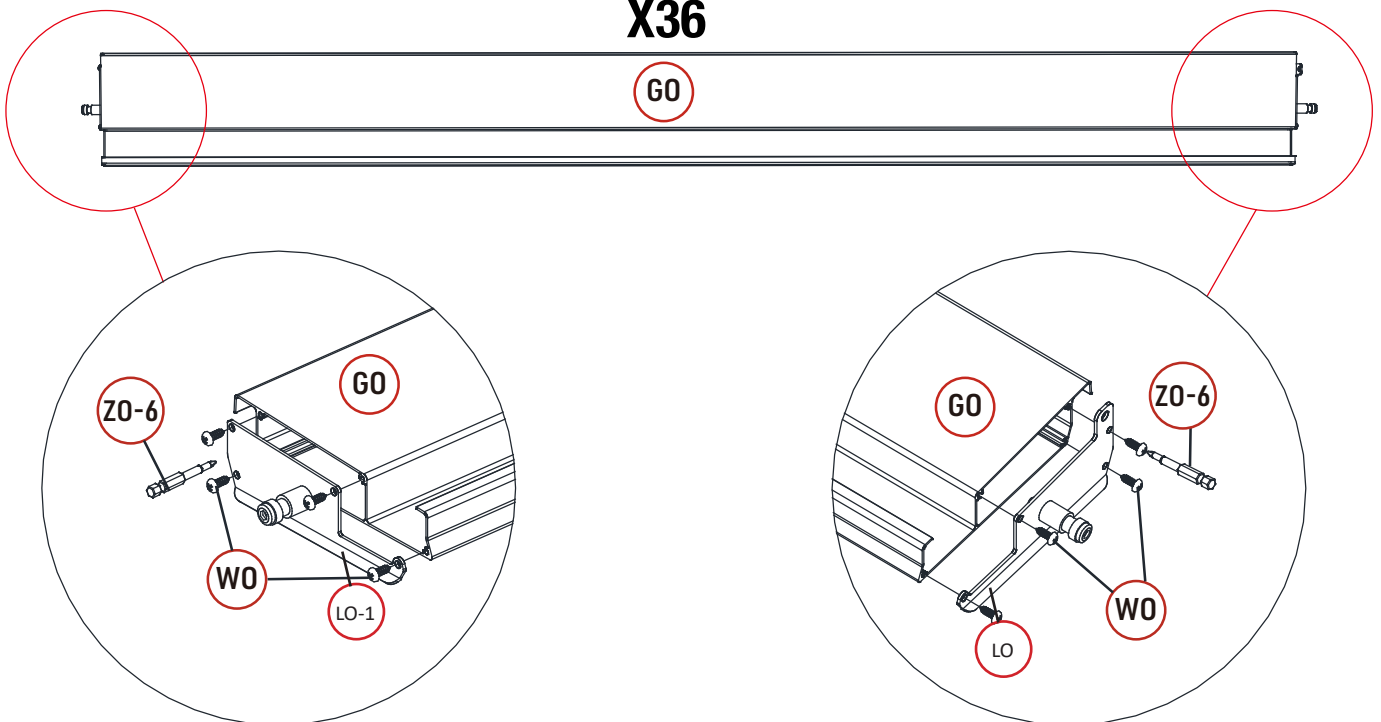

Installate la lamella principale nella seconda posizione prevista sulla pergola, partendo dal lato della manovella per formare il tetto.

Ripetere quindi, l'operazione per la seconda parte della pergola.

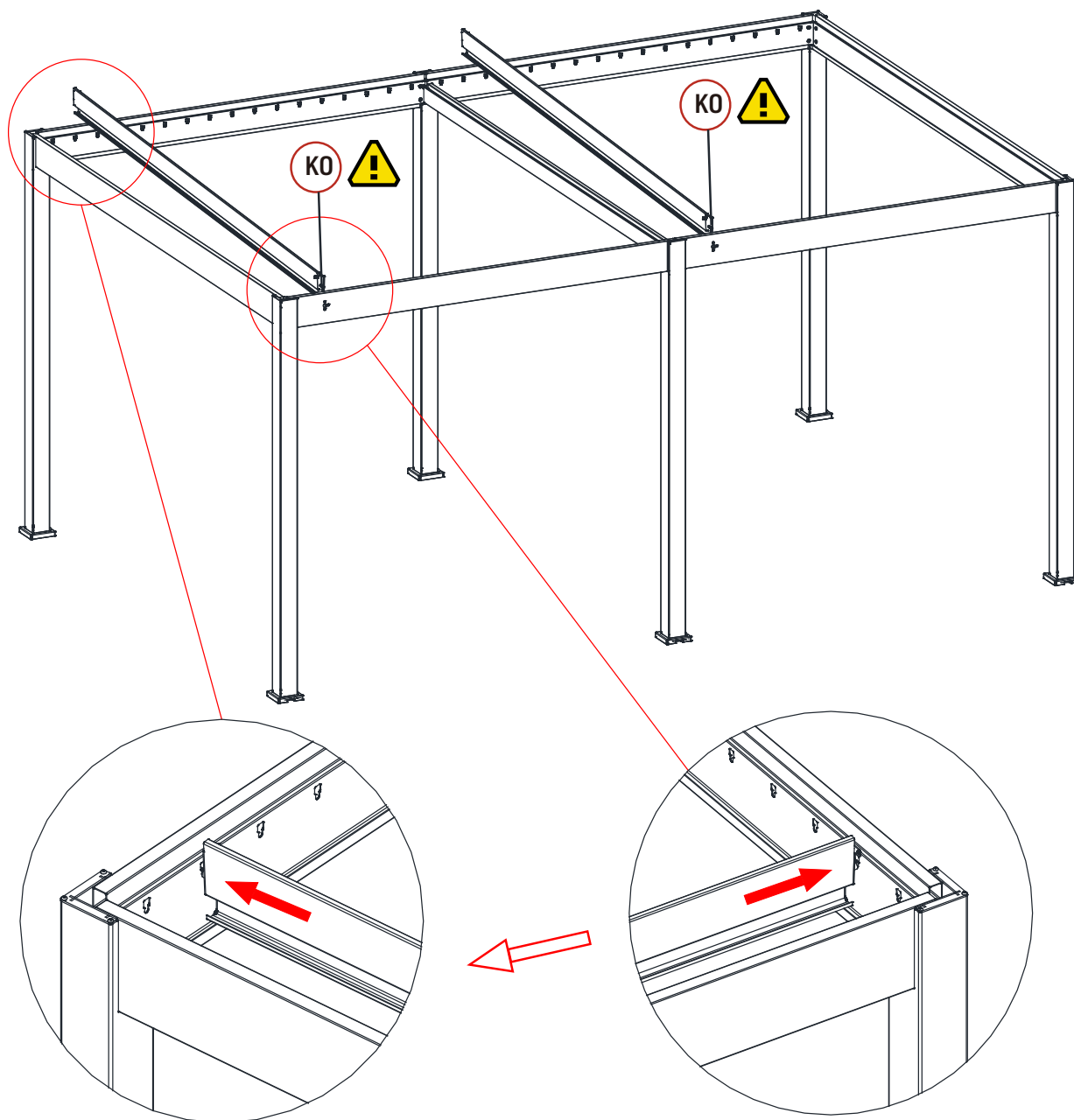

Inserite il cilindro **PO** attraverso la trave come indicato nello schema, quindi spingete finché non si incastra con il perno della lamella principale **KO**.

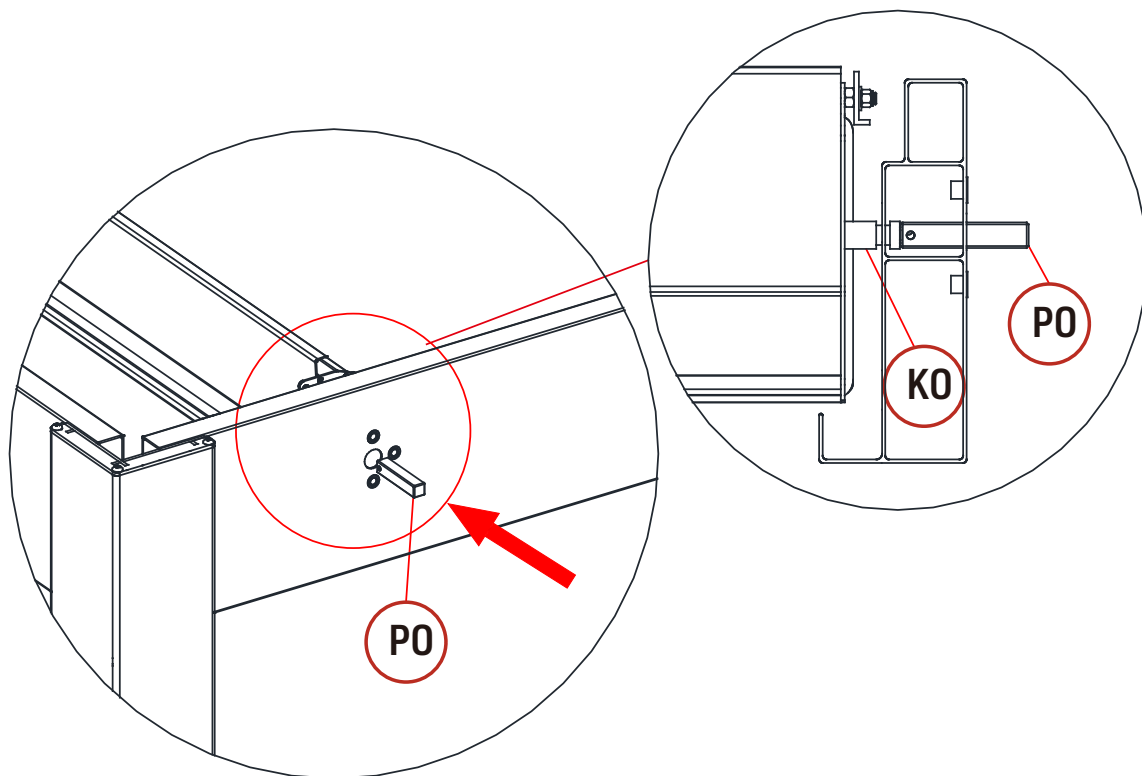

Collegate e avvitate la prima parte della scatola **OO** con la gearbox **NO** sulla trave principale **BO-1**, con i 3 bulloni **YO**, utilizzando la chiave Allen **ZO-3** o un avvitatore con una punta **ZO-4**.

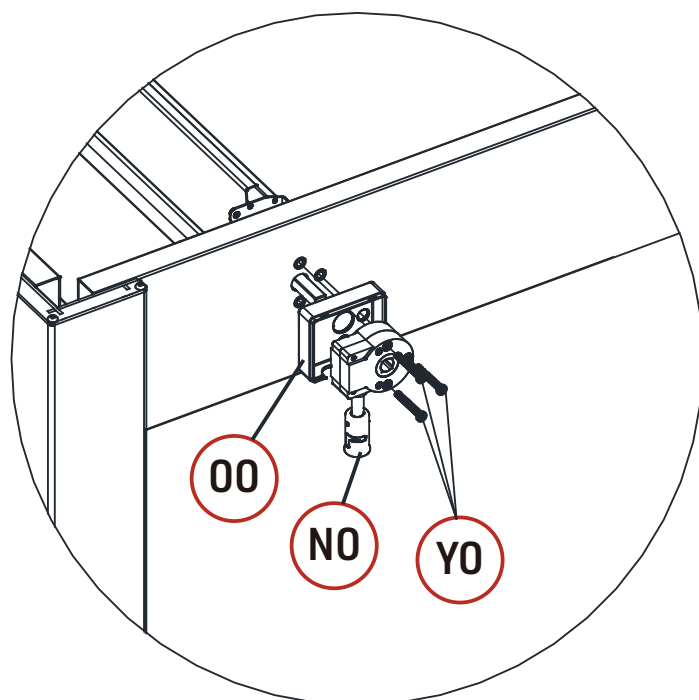

Ripetere quindi, l'operazione per la seconda parte della pergola.

Assicuratevi che il meccanismo manuale funzioni correttamente ruotando la lamella a destra e poi a sinistra con la manovella **HO**.

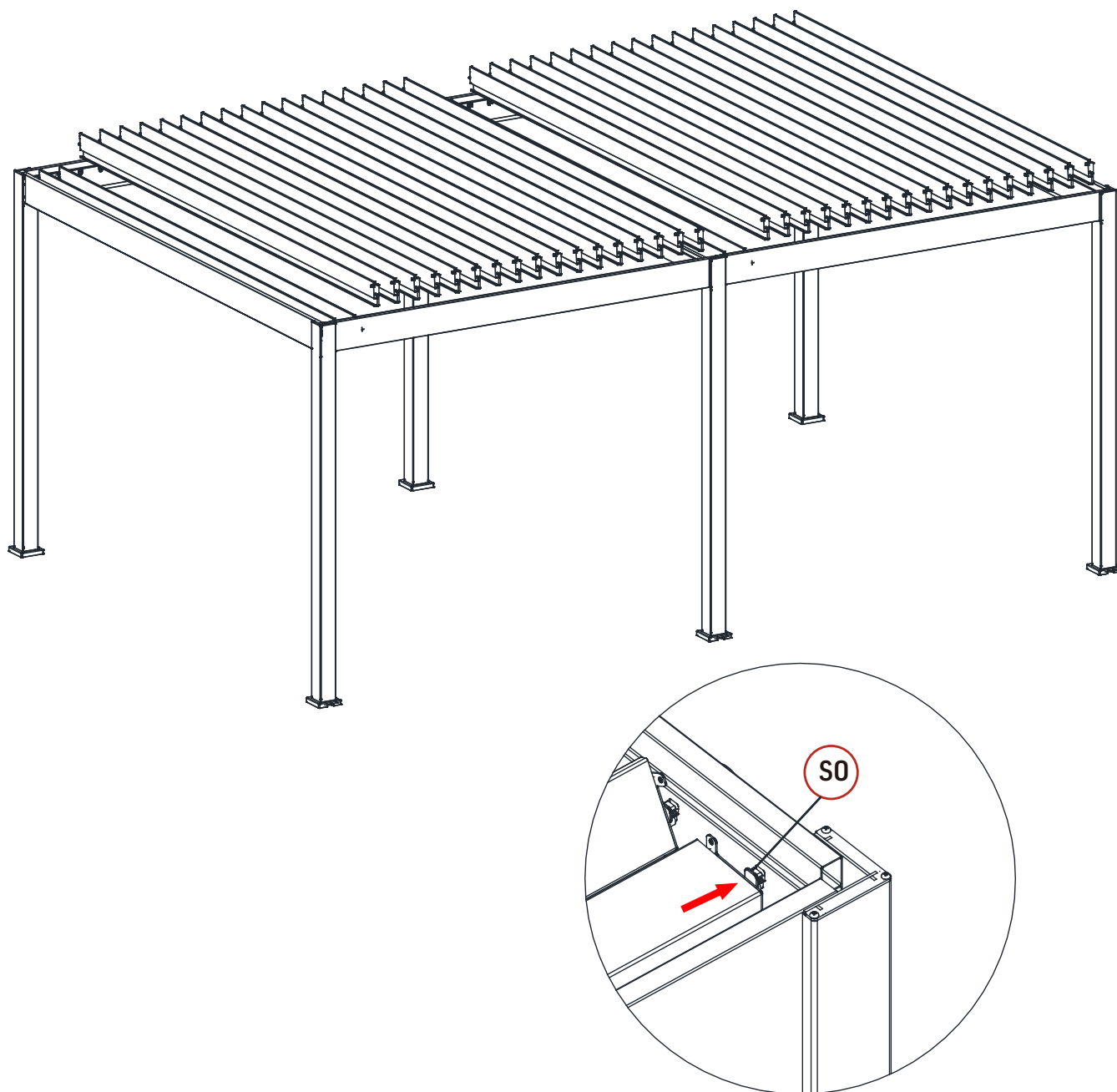

Mettete la lamella in posizione verticale, per installare le altre lamelle una dopo l'altra. Inserite quindi i cunei a mezzaluna **SO** come indicato nello schema. L'apertura a mezzaluna deve trovarsi sulla parte inferiore del cuneo.

Ripetere l'operazione per la seconda parte della pergola.

Fissate le viti **XO-2**, **VO** e **UO-1** su ciascun copri-lamella come indicato nello schema.

Fissate quindi, la barra di giunzione **FO** a tutte le lamelle con le rondelle **VO** e i dadi **UO**, utilizzando un avvitatore e la punta T20 **ZO-6** e la chiave **ZO-5** per tenere il dado.

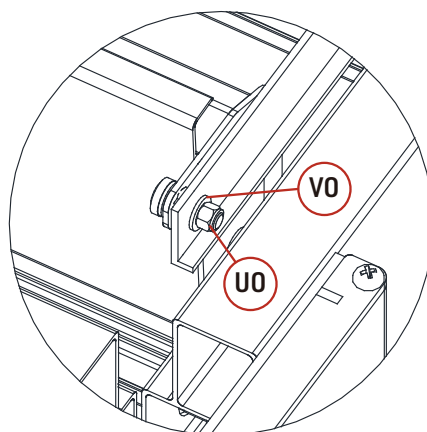
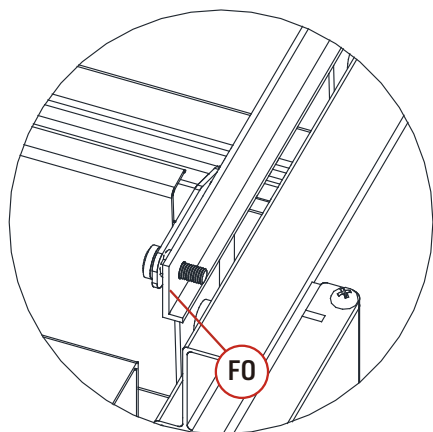
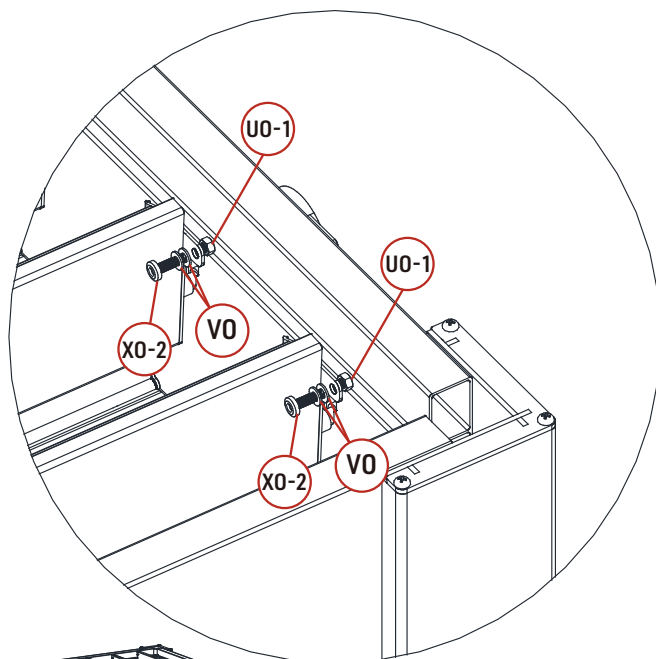
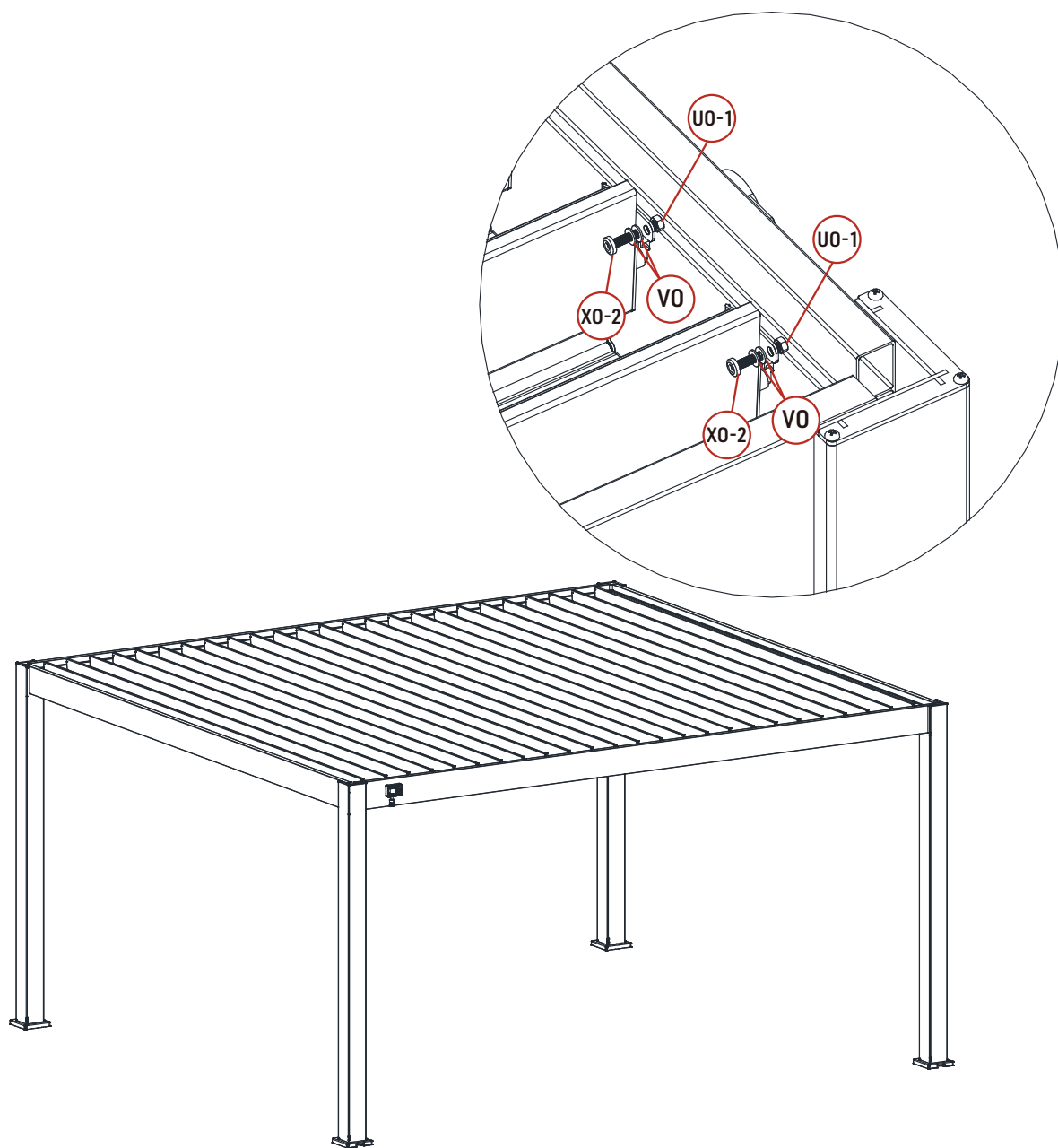

Inserite i tappi **RO** per coprire i fori negli angoli del telaio, come indicato nello schema.
Incastrate quindi la seconda parte della scatola **OO** per chiuderla.

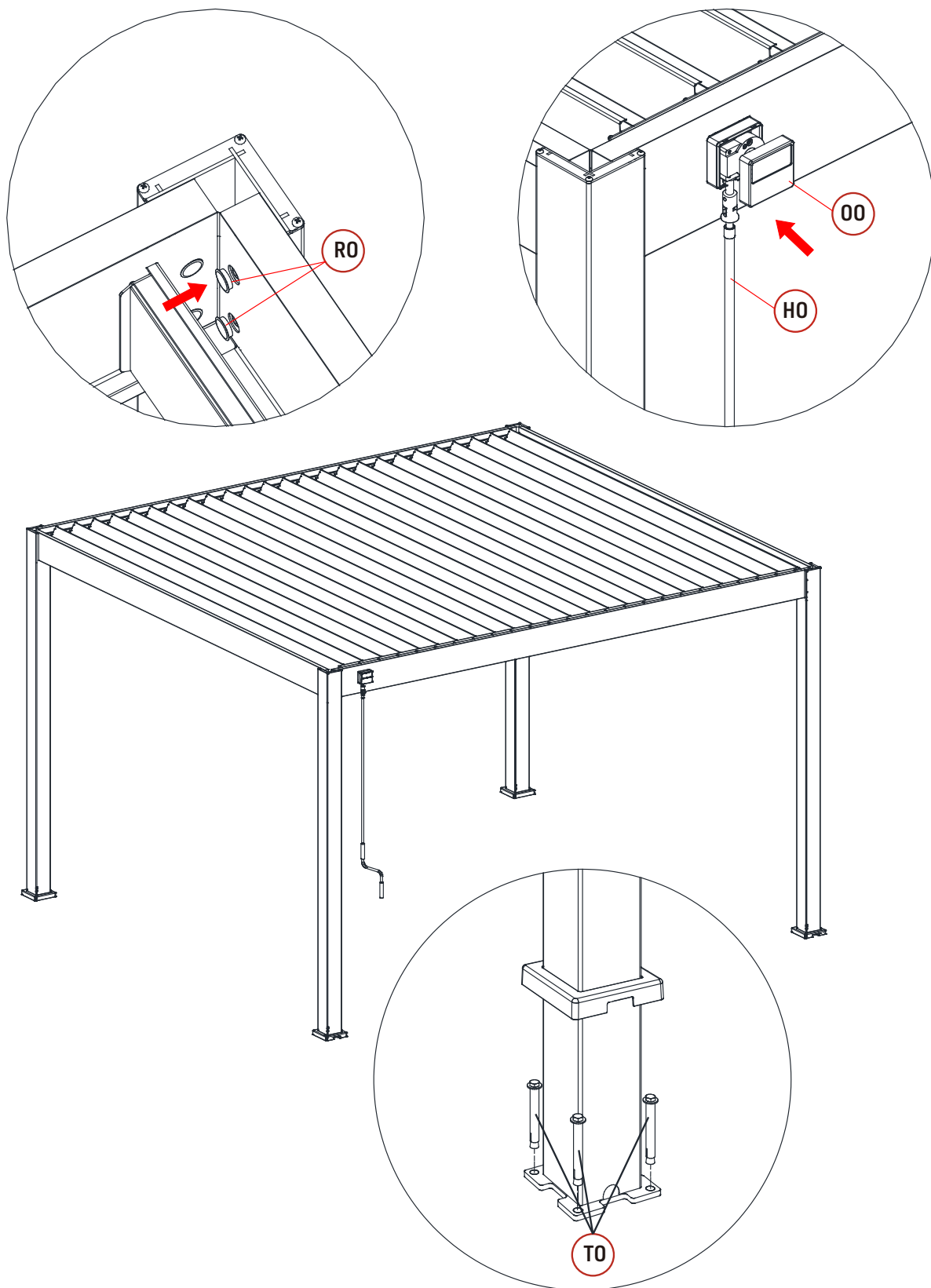

Infine, fissate la pergola a un pavimento duro e piano, utilizzando i tasselli a espansione **TO** grazie a un trapano a percussione con una punta da 12 mm (non fornita).