

Ombrea®

FR Pergola Bioclimatique Adossée 3x3M

EN 3x3M Wall-mounted louvered pergola / ES Pégola Bioclimática adosada 3x3M
IT Pergola bioclimatica addossata 3x3M

Anthracite/Dark Grey/Antracita/Antracite : 15-729087, Blanc/White/Blanco/Bianco : 15-729087

FR NOTICE DE MONTAGE p.2

EN INSTRUCTIONS MANUAL p.27

ES INSTRUCCIONES DE MONTAJE p.52

IT ISTRUZIONI DI MONTAGGIO p.76

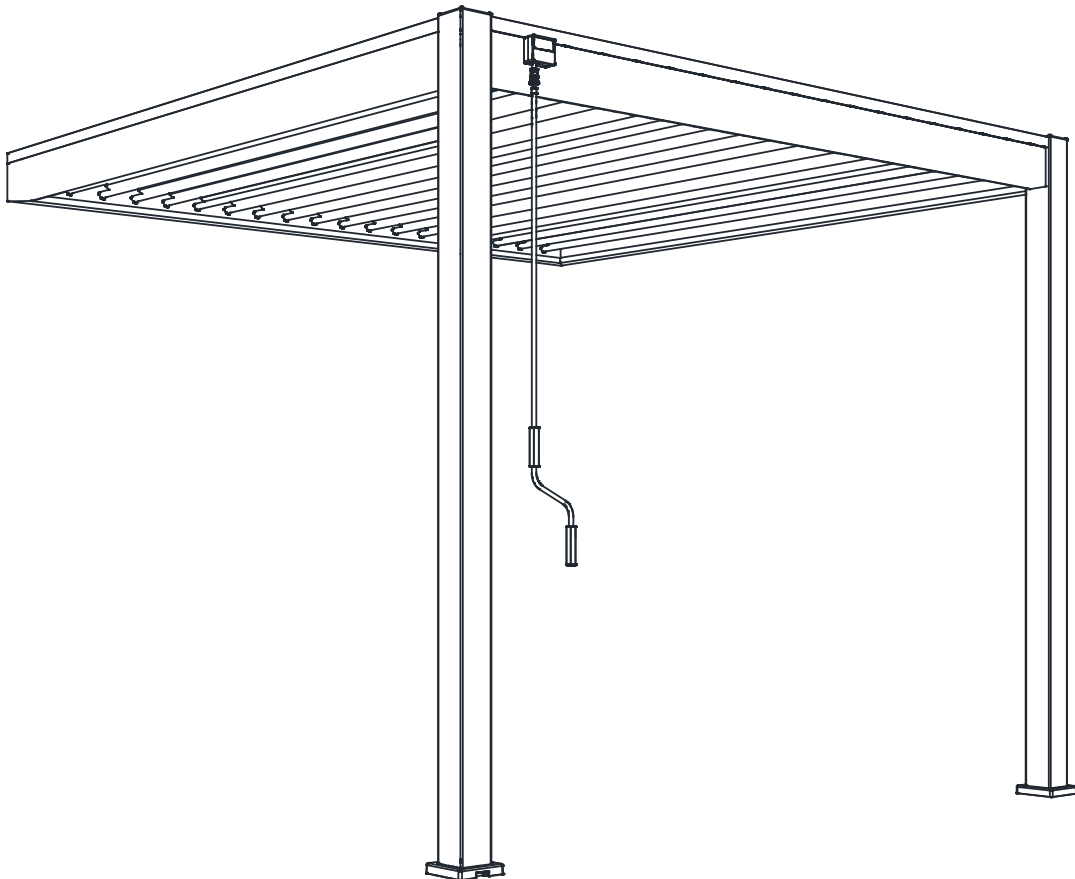

Pergola Bioclimatique Adossée 3x3M

Anthracite : 15-728981 / **Blanc** : 15-729087

Notice à conserver pendant toute la durée de vie du produit.

Nous vous demandons de lire attentivement la notice avant de procéder au montage.

L'utilisateur sera responsable des dommages ou blessures causés par une utilisation non conforme.

1. PRÉCAUTIONS D'UTILISATION

Ce produit ne doit pas être utilisé en cas de fortes intempéries : orage, vent violent, grêle, neige. Nous garantissons la résistance de la pergola pour des vents jusqu'à 100 km/h et un poids de neige maximal de 50kg/m².

En cas de vents forts ou de neige, il est vivement recommandé de laisser les lames en position ouverte. En cas d'oubli, il faudra déneiger la pergola afin d'éviter une surcharge importante sur les lames.

Notre pergola peut supporter de fortes pluies, mais, nous ne pouvons pas vous garantir une étanchéité à 100%.

En cas d'épisodes climatiques exceptionnels, son étanchéité peut être compromise. Ne pas laisser des produits craignant l'humidité sous la pergola. Ne pas monter sur le toit ni sur la structure de la pergola.

2. CONSEILS DE MONTAGE

Selon l'emplacement et la surface, les constructions peuvent être soumises à des déclarations de travaux ou de demande de permis de construire. Veuillez vous rapprocher de votre mairie pour obtenir les informations utiles avant le montage.

Montage du produit :

- 2 à 3 personnes sont nécessaires
- Retirer les films de protection (durée estimée à 1h)
- Ne pas laisser les enfants jouer à proximité de la zone de montage
- Attention aux risques de pincement
- Ne jamais serrer complètement les vis avant d'avoir assemblé la partie concernée
- Toutes les étapes d'assemblage doivent être scrupuleusement respectées
- Contrôler les niveaux, les diagonales et l'aplomb
- Fixer la pergola qu'une fois assemblée

Aucune modification ne peut être apportée au produit. Les produits modifiés par l'utilisateur ne sont plus couverts par la garantie du fabricant.

Le lieu d'emplacement doit être choisi de manière appropriée. Il est recommandé d'éviter de monter votre pergola, par temps de pluie, face aux vents dominants et sous un arbre.

La pergola doit être montée sur une fondation adéquate stable et nivelée, il est recommandé de l'installer sur une dalle en béton ou sur des plots en béton 25x25 cm au niveau de chaque poteau. Nous vous demandons d'ancrer correctement la pergola au sol à l'aide des pièces TO.

Si vous souhaitez positionner votre pergola près de votre maison ou d'un bâtiment, nous vous demandons de vérifier la présence de gouttières pour l'écoulement des eaux. La pergola Ombréa® ne pourra pas supporter et garantir une étanchéité parfaite si les eaux de pluie de votre habitation s'y déversent.

En cas de non-respect des recommandations de montage, la garantie ne pourra être appliquée.

3. ENTRETIEN DE LA PERGOLA

Un entretien régulier est nécessaire pour assurer sa longévité et son aspect esthétique, nous recommandons de :

- Laver votre pergola 1 à 2 fois par an à l'eau douce à l'aide d'une éponge ou d'un chiffon. Ne pas utiliser de détergent ou matériau abrasif.
- Vérifier le serrage des vis régulièrement (au moins 1 fois par an).
- Huiler les pièces de quincaillerie régulièrement (au moins 1 fois par an).
- Veiller à ce que rien ne gêne l'écoulement des eaux dans les gouttières (feuilles, branches...).
- Enlever l'eau qui pourrait stagner autour des pieds de la pergola (soulever les protections).

4. GARANTIE

Ombréa® garantit la disponibilité des pièces détachées pendant 2 ou 5 ans (suivant le produit). Elle ne s'applique que si les consignes de stockage, de montage, d'utilisation, d'entretien sont respectées.

La garantie ne couvre pas :

- L'usure normale inhérente aux produits.
- La perte ou la casse de toutes pièces lors du déballage ou de l'installation.
- Le manque de soins raisonnable, la négligence, le vandalisme, les impacts avec des objets étrangers, l'usage de la force, le contact avec des abrasifs, l'esthétique, le démontage, la reconstruction ou relocalisation.
- Les forces majeures : grêle, vents forts, tempêtes, neige, inondations, foudre...
- Produit modifié par l'utilisateur

La garantie comporte seulement le remplacement de la pièce détachée ou du produit fourni, à l'exclusion de tout frais et indemnités de quelque nature que ce soit.

Toute demande de garantie doit être formulée au point de vente (magasin ou site internet) dans lequel vous avez acheté votre produit.

5. LISTE DES PIÈCES (PAR CARTON)



Avant de procéder au montage de votre pergola bioclimatique, il est nécessaire de vérifier que toutes les pièces soient présentes et ne soient pas endommagées.



Toute pièce manquante doit être signalée dans les 10 jours suivant l'achat. Vous pouvez passer par votre revendeur ou faire la demande directement sur notre site sav.comintes.com.

Ne pas jeter l'emballage sans s'assurer du bon fonctionnement de la pergola.

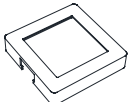

CARTON 1/4 (POTEAU ET QUINCAILLERIE)

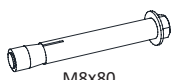
| Référence | Schéma | Quantité |
|-----------|--|----------|
| AO |  POTEAU | 2 |





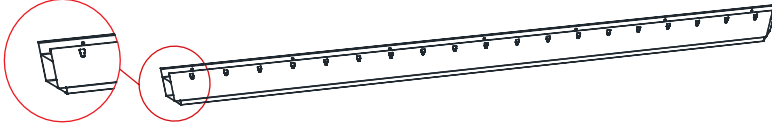

| Référence | Schéma | Quantité |
|-----------|--|----------|
| IO |  CACHE PLATINE | 2 |
| JO |  PLATINE DE FIXATION | 2 |











| Référence | Schéma | Quantité |
|-----------|--|----------|
| TO |  M8x80 CHEVILLE BÉTON | 8 |
| XO-1 |  6x35 BOULON 6X35 | 8 |



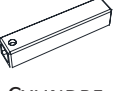
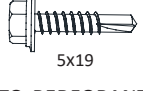
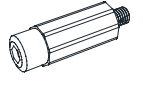

CARTON 2/4 (POUTRE ET QUINCAILLERIE)



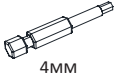

| Référence | Schéma | Quantité |
|-----------|--|----------|
| BO-1 |  POUTRE PRINCIPALE | 1 |
| BO-2 |  POUTRE ARRIÈRE | 1 |
| CO-1 |  POUTRE LATÉRALE GAUCHE | 1 |
| CO-2 |  POUTRE LATÉRALE DROITE | 1 |

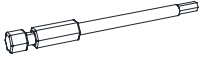
CARTON 2/4 (POUTRE ET QUINCAILLERIE)

| Référence | Schéma | Quantité |
|-----------|---|----------|
| DO-1 |  EXTENSION DE POUTRE AVANT | 1 |
| DO-2 |  EXTENSION DE POUTRE ARRIÈRE | 1 |
| DO-3 |  EXTENSION DE POUTRE LATÉRALE GAUCHE | 1 |
| DO-4 |  EXTENSION DE POUTRE LATÉRALE DROITE | 1 |
| FO |  BARRE DE CONNEXION (VIS INCLUSES) | 1 |
| HO |  MANIVELLE | 1 |

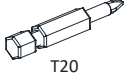
| Référence | Schéma | Quantité | Référence | Schéma | Quantité |
|-----------|---|----------|-----------|---|----------|
| LO-2 |  ANGLE PLASTIQUE | 2 | UO |  ÉCROU | 56 |
| NO |  GEARBOX | 1 | VO |  RONDELLE | 19 |
| OO |  BOITIER | 1 | XO |  6x40 BOULON 6x40 | 37 |
| PO |  CYLINDRE | 1 | XO-2 |  5x19 VIS AUTO-PERFORANTE 5x19 | 8 |
| QO |  VIS DE FIXATION POUTRE | 8 | YO |  6x45 BOULON 6x45 | 3 |
| RO |  CAPUCHON DE FINITION | 8 | ZO-1 |  4MM CLÉ ALLEN 4MM | 1 |
| SO |  CALE DEMI-LUNE | 38 | | | |



| Référence | Schéma | Quantité |
|-----------|---|----------|
| ZO-2 |  4MM EMBOUT VISSEUSE 4MM | 1 |
| ZO-3 |  6MM CLÉ ALLEN 6MM | 1 |
| ZO-4 |  6MM EMBOUT VISSEUSE 6MM | 1 |
| ZO-5 |  10MM CLÉ PLATE 10MM | 1 |

| Référence | Schéma | Quantité |
|-----------|---|----------|
| ZO-6 |  T20 EMBOUT VISSEUSE T20 | 1 |
| ZO-7 |  EMBOUT DE VISSEUSE | 1 |
| ZO-8 |  COLLE | 1 |
| TO-1 |  CHEVILLE 8X100 | 1 |

CARTON 3/4 (LAME)

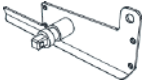
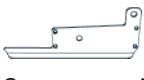
| Référence | Schéma | Quantité |
|-----------|---|----------|
| GO |  LAME | 9 |

| Référence | Schéma | Quantité |
|-----------|---|----------|
| KO |  CACHE LAME PRINCIPAL | 1 |
| LO |  CACHE LAME A | 18 |

| Référence | Schéma | Quantité |
|-----------|---|----------|
| LO-1 |  CACHE LAME B | 19 |
| MO |  ERGOT | 37 |

| Référence | Schéma | Quantité |
|-----------|---|----------|
| WO |  4x16 Vis 4x16 | 152 |

CARTON 4/4 (LAME)

| Référence | Schéma | Quantité |
|-----------|--|----------|
| GO |  LAME | 10 |

Les pièces en aluminium sont les suivantes : AO, BO-1, BO-2, CO-1, CO-2, DO-1, DO-2 DO-3, DO-4, FO, GO, IO, KO, LO et LO1.

La visserie, ainsi que les autres pièces sont soit en Inox, en acier galvanisé, en plastique ou en nylon. Pour plus de renseignements, référez-vous aux caractéristiques techniques du produit et consultez notre page FAQ sur le site www.pergola-ombrea.com ou rapprochez-vous de votre revendeur.

6. MATÉRIEL (NON FOURNI) NÉCESSAIRE POUR LE MONTAGE



Lunettes et gants de protection



2 escabeaux



Perforateur + foret béton 12mm



Perceuse visseuse

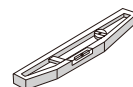

Niveau à bulle



Cutter



Casque de sécurité

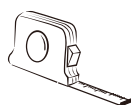

Mètre ruban



Colle

7. CONTACT

Soucieux de nous améliorer, n'hésitez pas à nous faire part de vos remarques et suggestions à l'adresse suivante : contact@pergola-ombrea.com

Nous serions ravis de recevoir les belles photos de votre installation.

L'équipe Ombrea vous remercie pour votre achat et vous souhaite des jours heureux sous votre pergola!

8. PLAN DE MONTAGE (dimensions en mm)

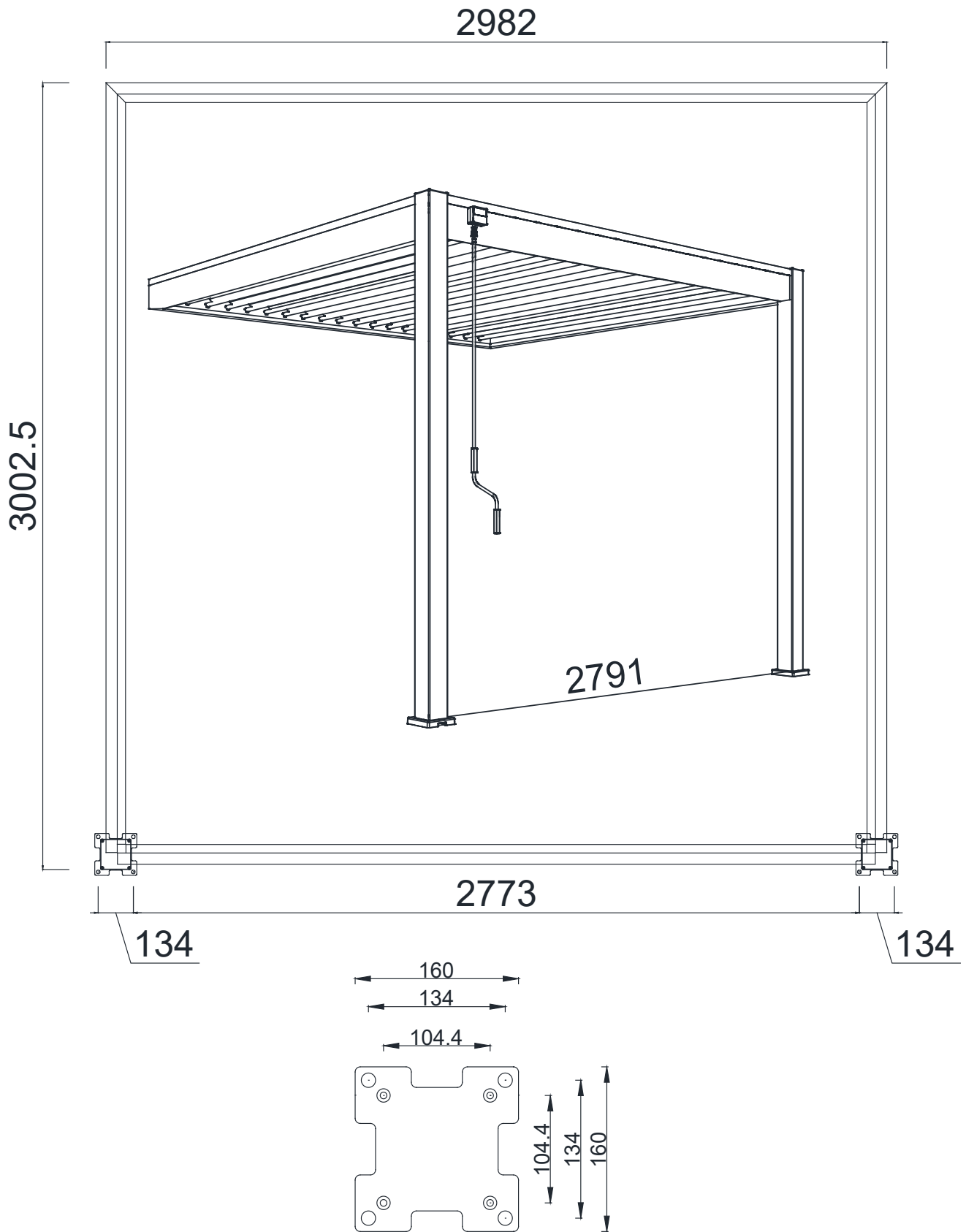

9. ÉTAPES DE MONTAGE

Afin d'éviter tout endommagement de votre pergola durant le processus de montage, nous vous recommandons de les assembler sur une table, sur des tréteaux ou d'aménager une surface plate et propre.

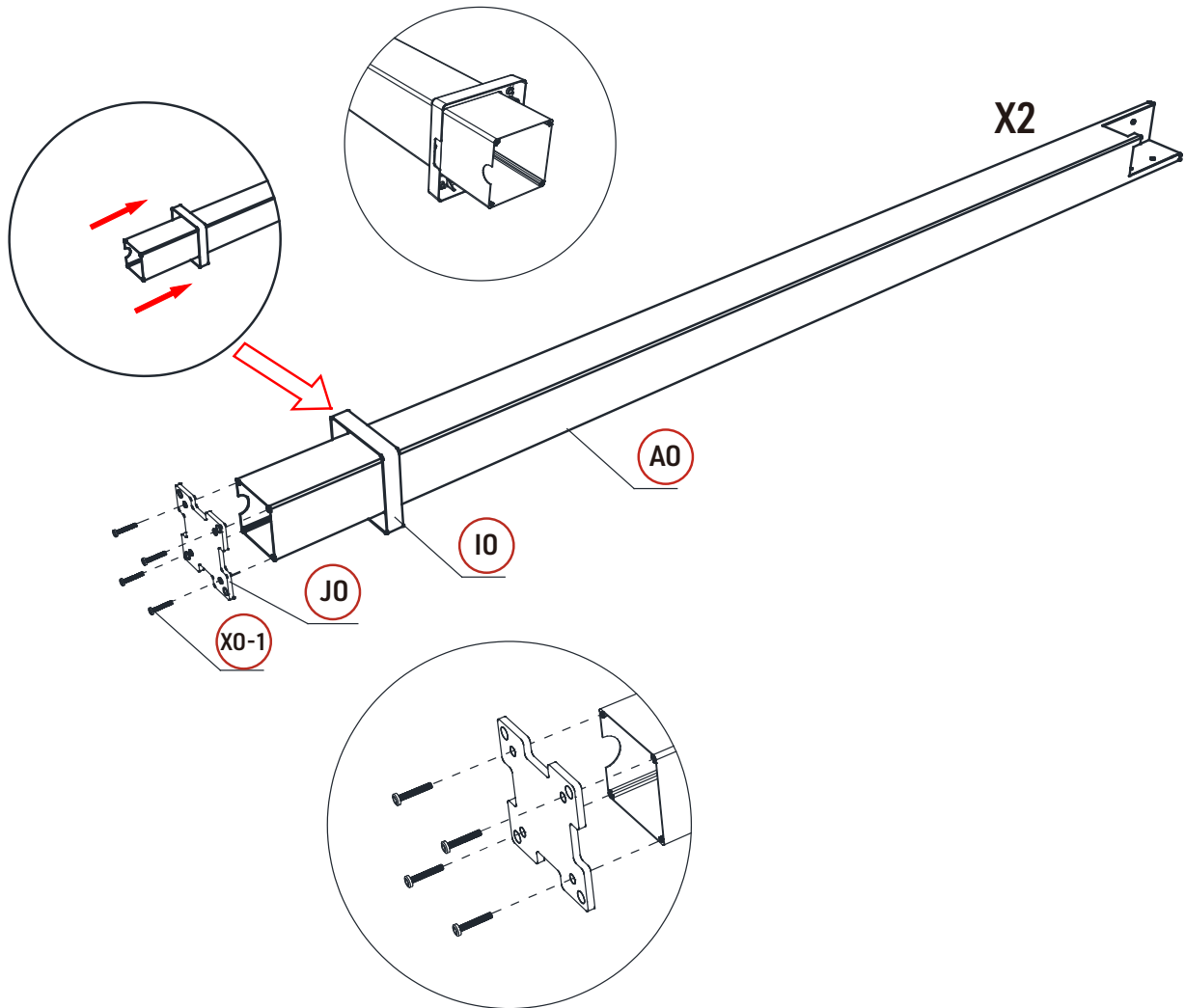

Glisser les caches **IO** sur les poteaux **AO**, en positionnant l'ouverture dans le même sens que l'ouverture située sur le poteau en forme de demi-lune.

Puis, fixer la platine **JO** avec les vis **XO-1** à l'aide d'une visseuse. Commencer par serrer légèrement, puis complètement une fois que toutes les vis sont positionnées.

Séparer les extensions **DO-1**, **DO-2**, **DO-3** et **DO-4** des poutres **BO-1**, **BO-2**, **CO-1** et **CO-2**. Garder les pièces retirées pour plus tard.

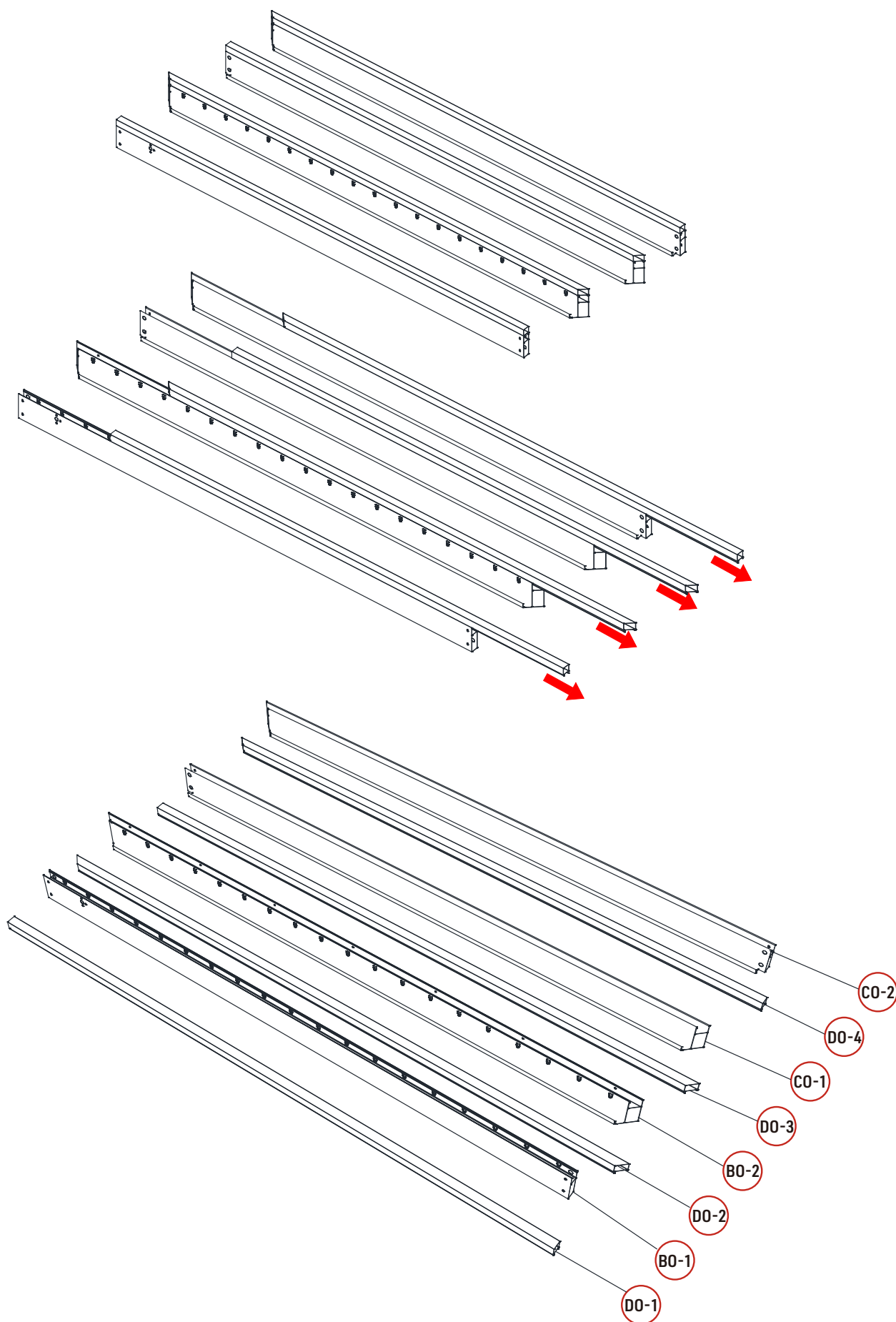

Insérer les angles **LO-2** dans la poutre murale **BO-2**, puis visser comme indiqué sur le schéma avec les vis auto-perforantes **XO-2**, à l'aide d'une visseuse et de l'embout **ZO-7**.

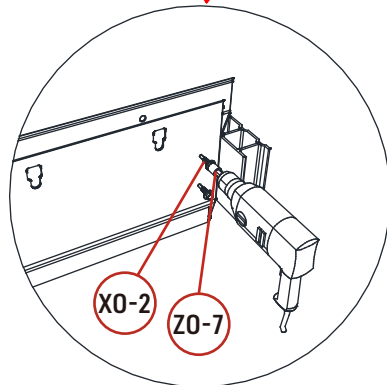
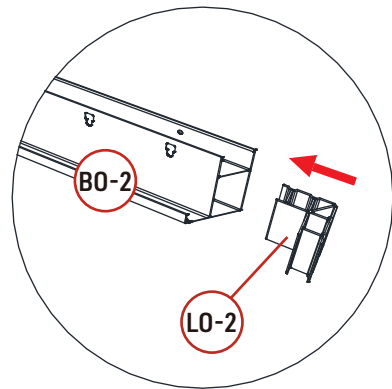
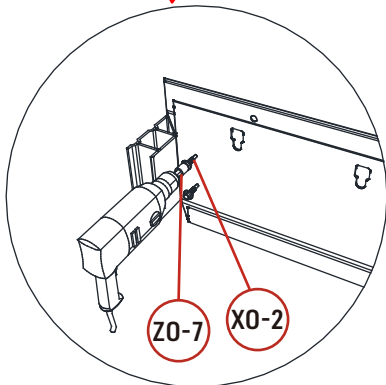
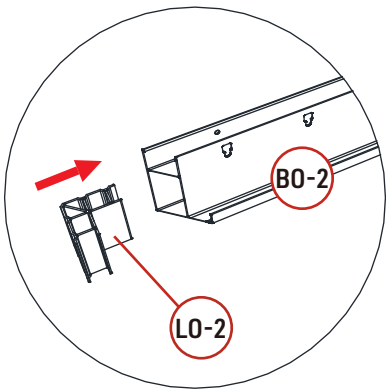

Sur un mur plat, positionner la poutre murale **BO-2** sur la façade à 237 cm de hauteur.

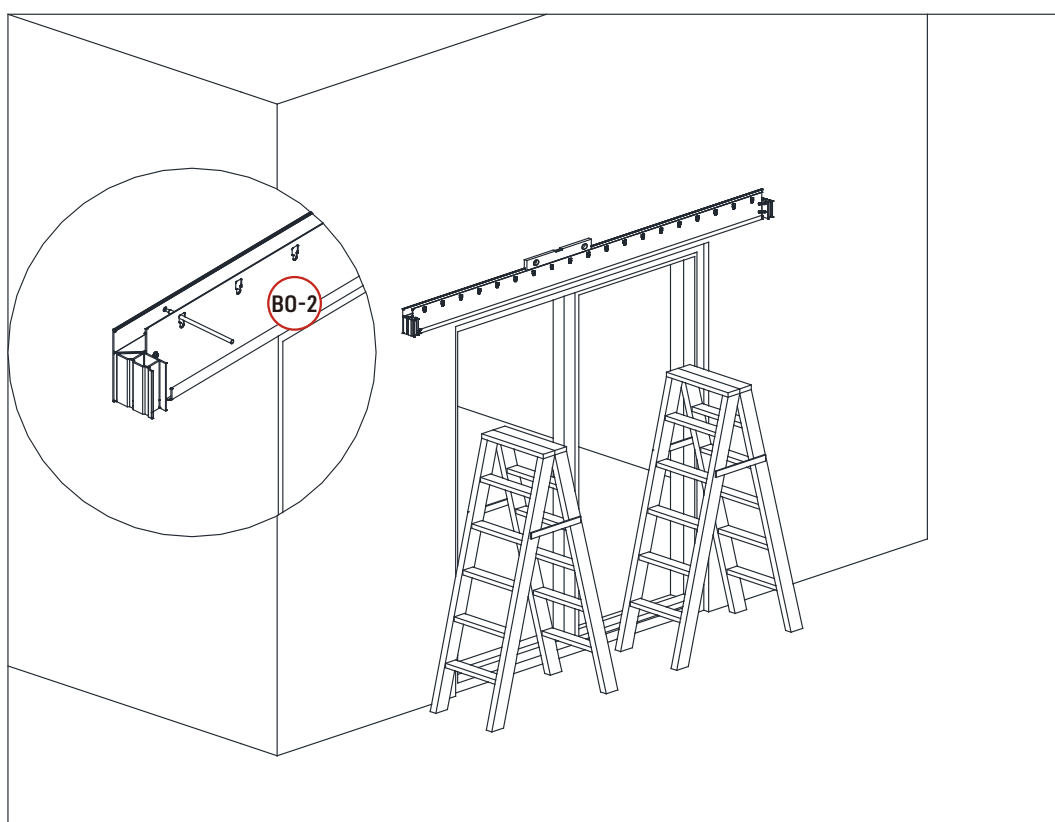

À l'aide de 2/3 personnes, en utilisant un niveau à bulle s'assurer que la poutre murale **BO-2** soit bien droite et avec un crayon marquer les trous de perçage, avant de retirer la poutre.

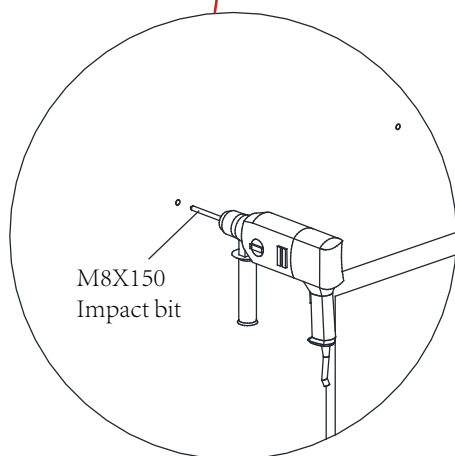
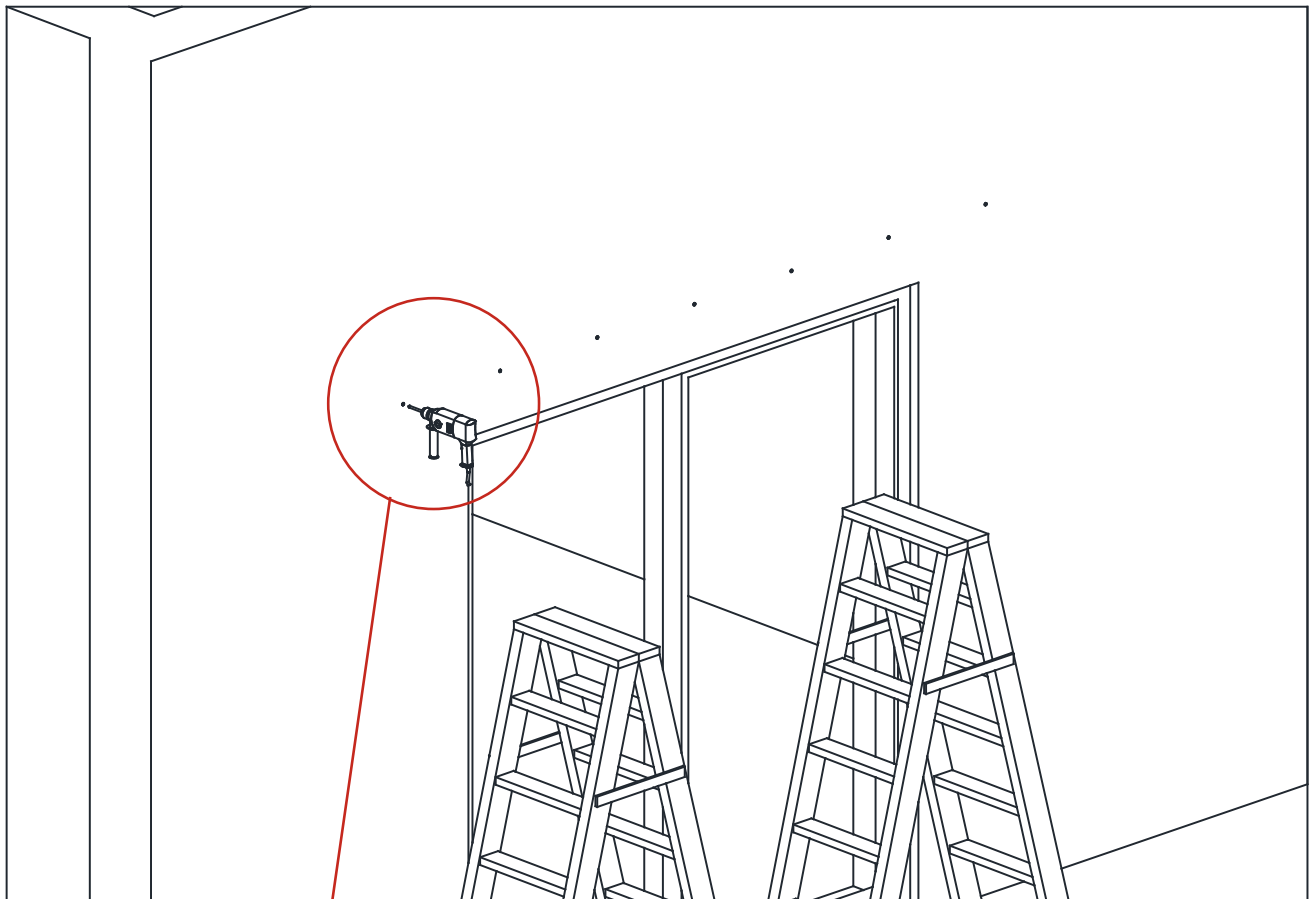

Percer les trous marqués au mur, à l'aide d'un perforateur et d'un foret M8x150.

Petit conseil : pour une étanchéité maximale, il est recommandé d'appliquer une colle entre le mur et la poutre murale.

Repositionner la poutre murale **BO-2** et la maintenir à niveau pour qu'elle soit bien droite. Puis, insérer les chevilles **TO-1** comme indiqué sur le schéma.

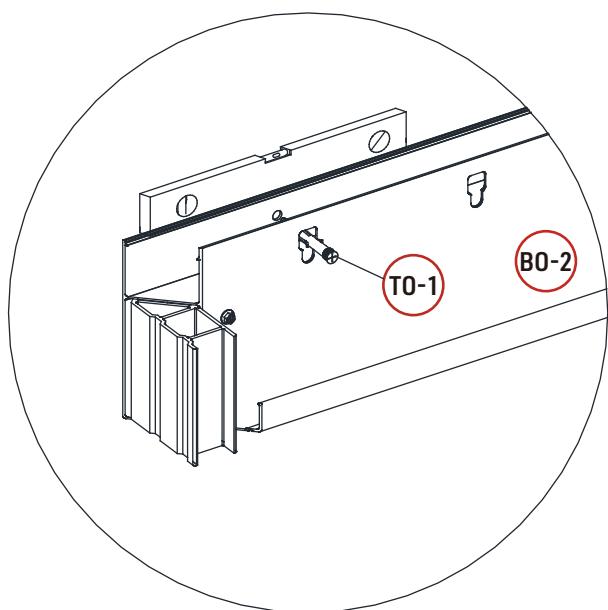
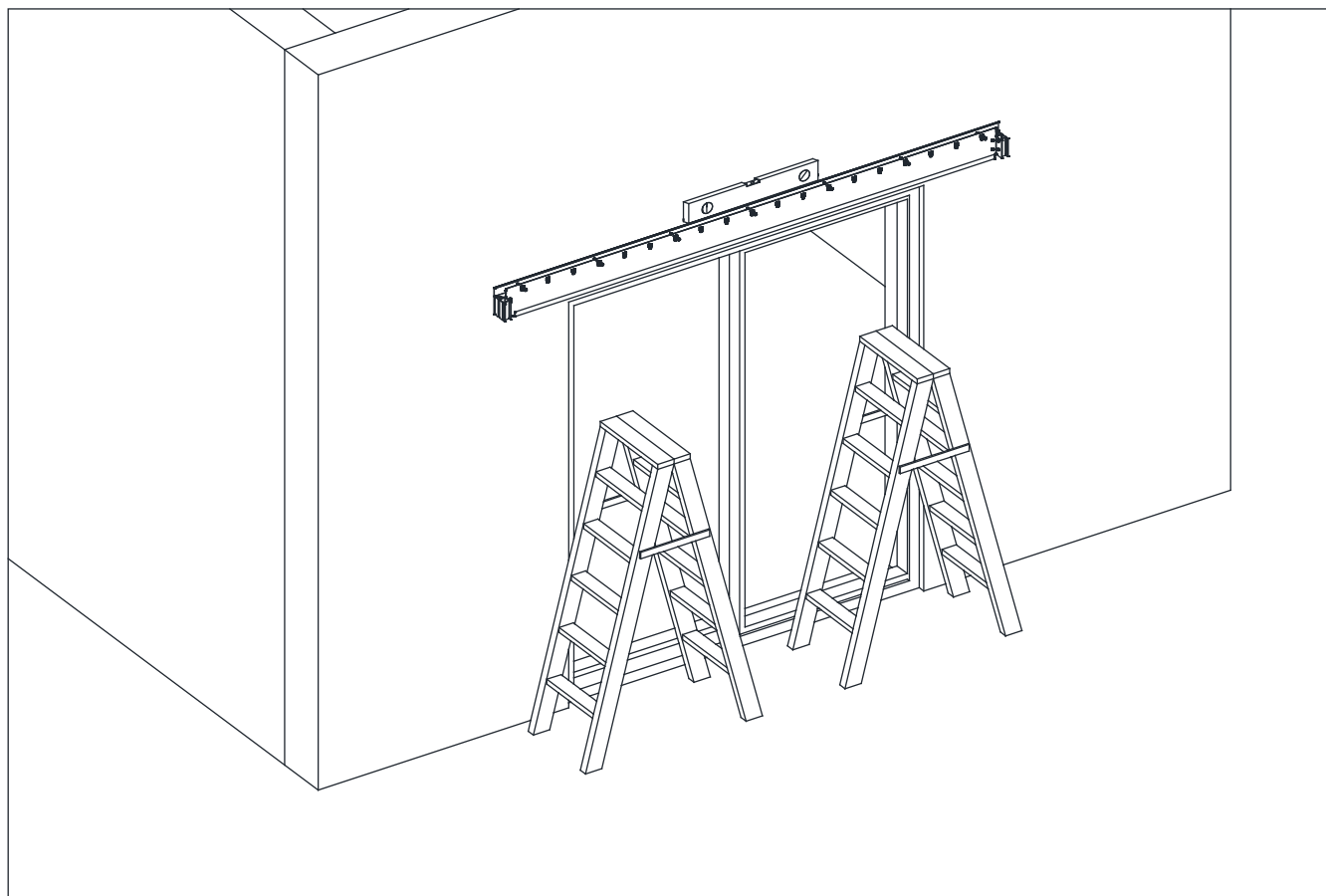

Emboîter l'extension de poutre **DO-2** sur la poutre murale **BO-2**.

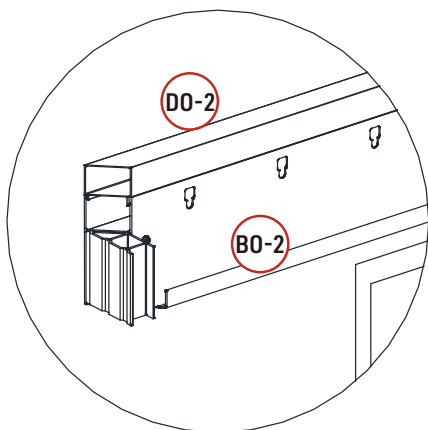
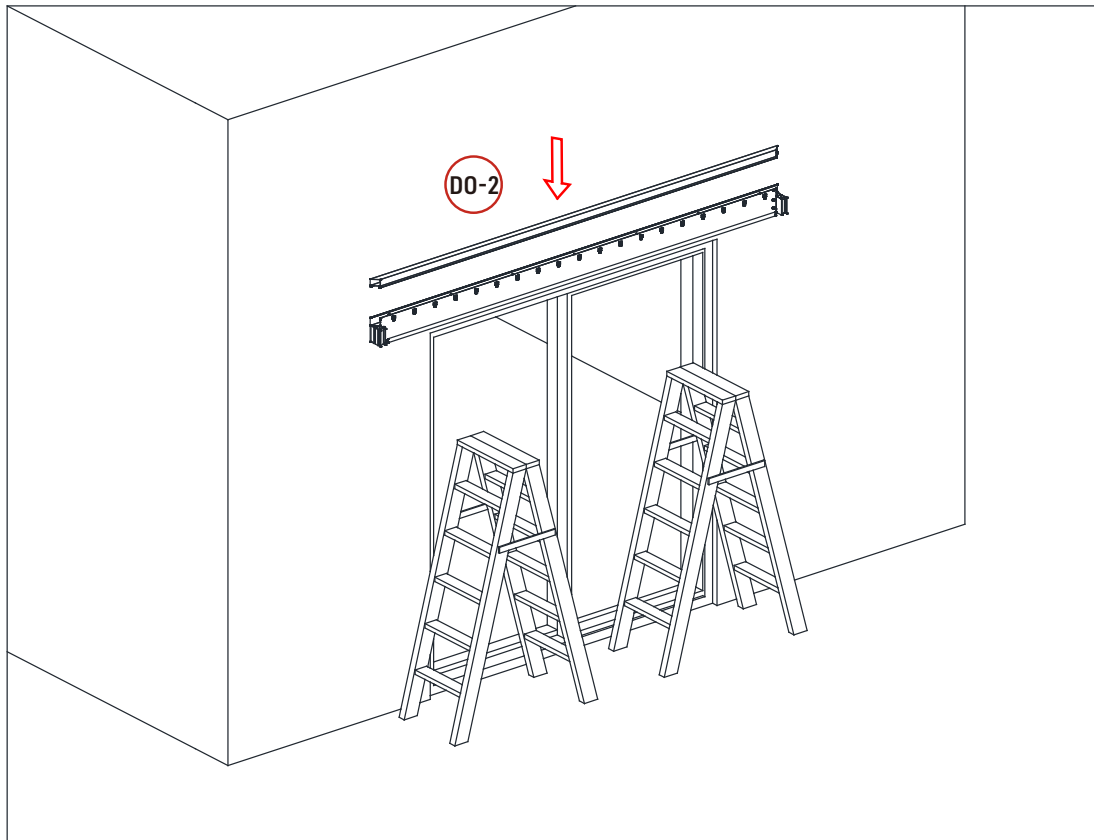

Fixer comme indiqué sur le schéma, les poutres **CO-1** et **CO-2** sur les poteaux **AO** avec les vis **QO**, à l'aide d'une visseuse et de l'embout **ZO-4** ou de la clé Allen **ZO-3**.
Puis, raccorder l'ensemble à la poutre murale **BO-2** en emboîtant à la pièce **LO-2**.

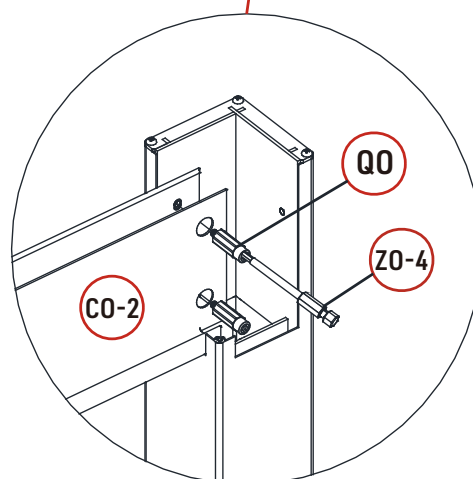
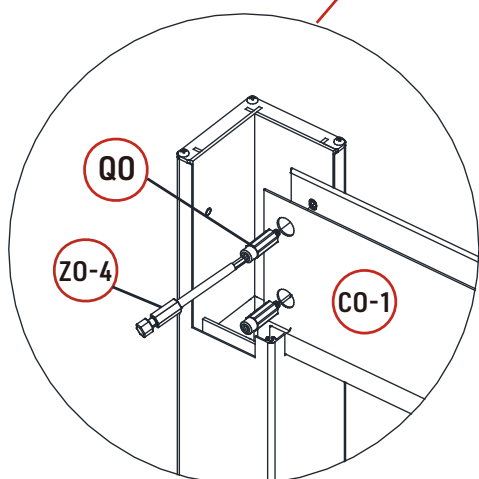
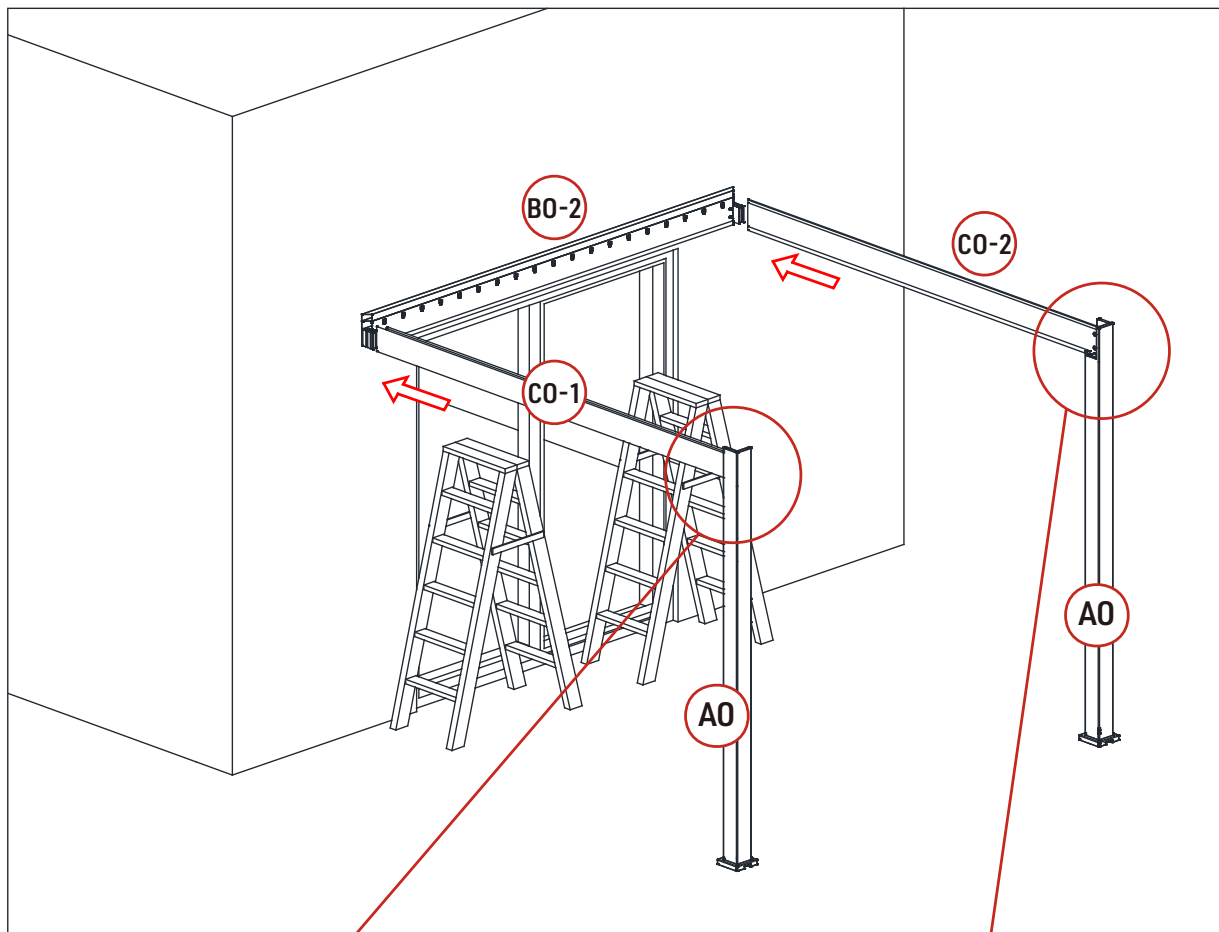

Fixer de chaque côté les poutres latérales **CO-1** et **CO-2** à la pièce **LO-2** avec les vis auto-perforantes **XO-2** comme indiqué sur le schéma, à l'aide d'une visseuse et de l'embout **ZO-7**.

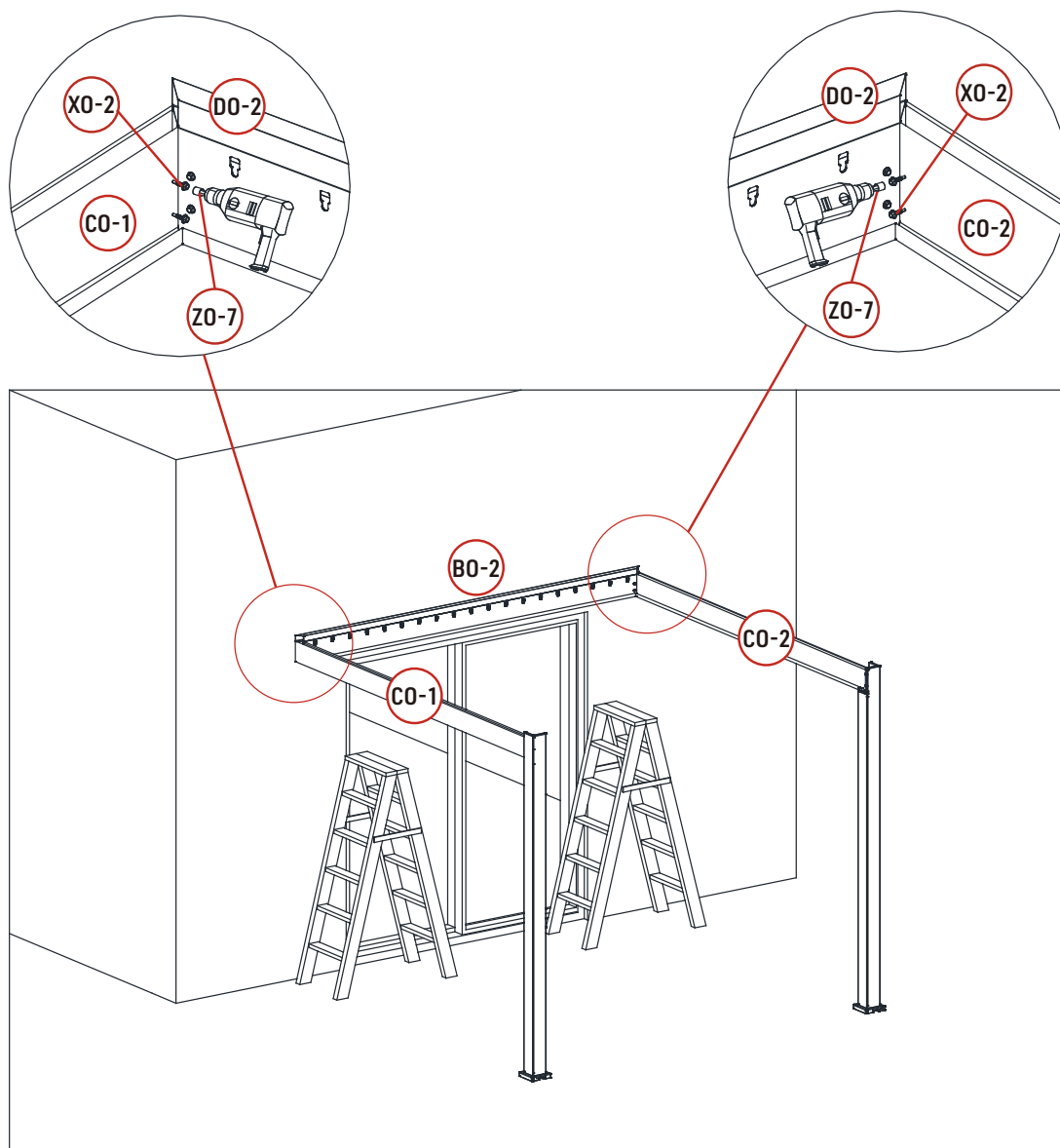

Appliquer la colle **ZO-8** dans les angles des deux côtés de la structure pour une étanchéité maximale, comme indiqué sur le schéma.

Puis, pour refermer le cadre, fixer la poutre avant **BO-1** sur les poteaux **AO** avec les vis **QO**, à l'aide d'une visseuse et de l'embout **ZO-4** ou de la clé allen **ZO-3**.

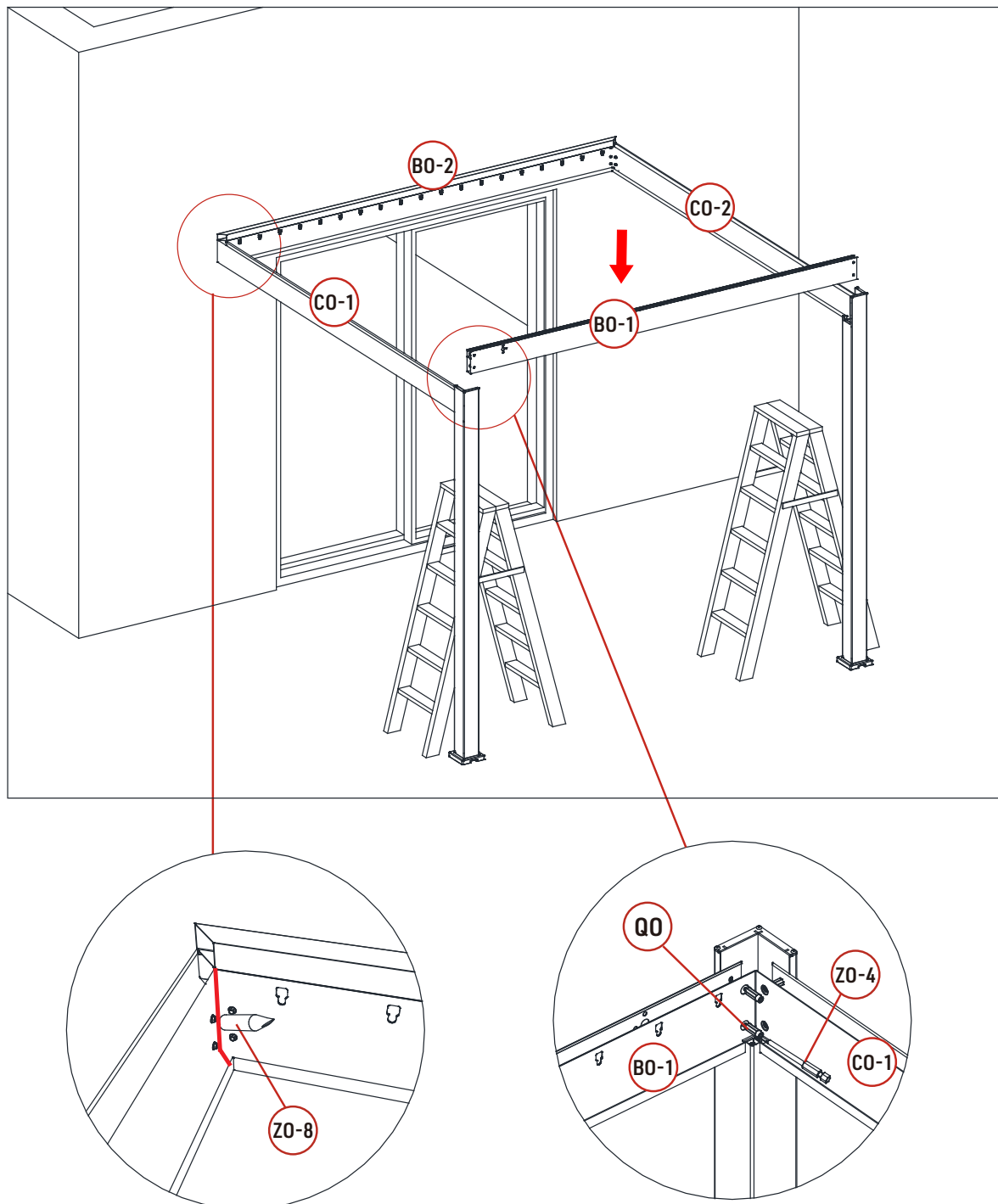

Associer et visser la première partie du boîtier **00** avec la gearbox **NO** sur la poutre principale **BO-1**, avec les 3 boulons **YO**, à l'aide de la clé Allen **ZO-3** ou d'une visseuse et de l'embout **ZO-4**.

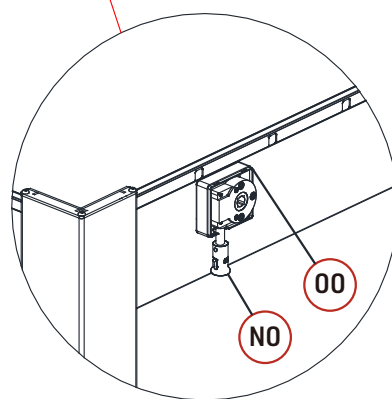
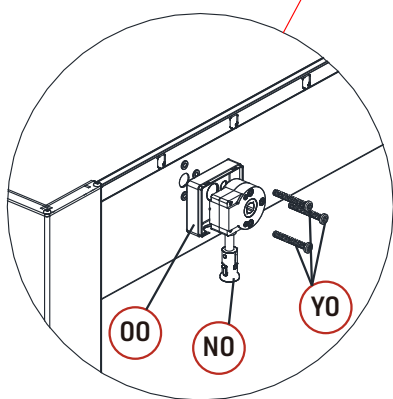
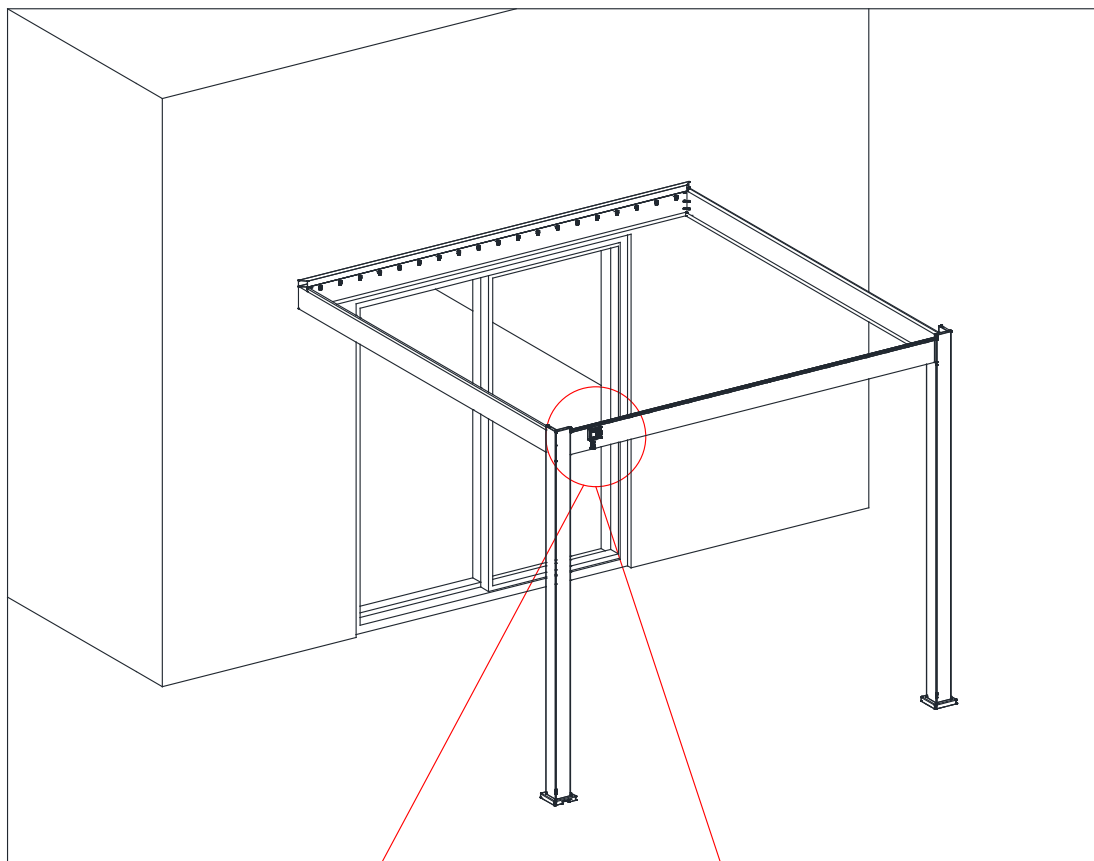

Fixer la pergola sur un sol dur et plat en béton, avec les chevilles à expansion **TO** à l'aide d'un perforateur et d'un foret 12mm (non fourni).

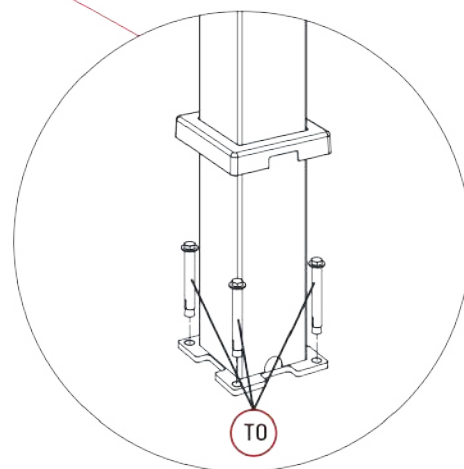
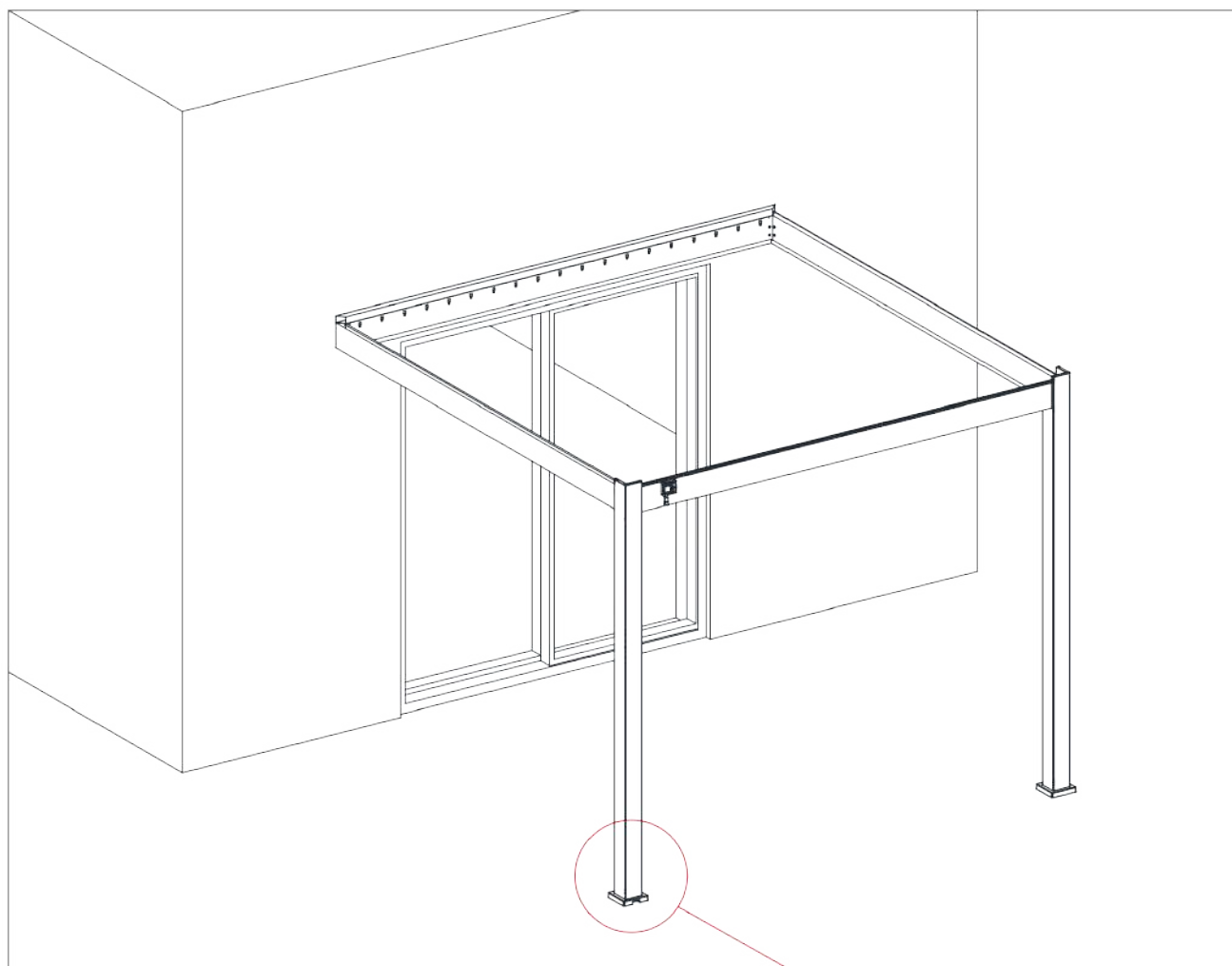

Constituer et fixer l'ergot correspondant à l'ensemble des pièces **XO**, **MO** et **UO** dans les caches lames **LO** et **LO-1**. S'assurer que l'ergot est bien installé dans le bon sens pour la pièce **LO** et pour la pièce **LO-1**, comme indiqué sur le schéma.

Utiliser une visseuse et l'embout **ZO-2** pour faciliter l'insertion du boulon **XO** dans l'écrou **UO**. Pour ne pas être blessé et pour que l'opération ne soit pas trop difficile, nous recommandons de maintenir l'écrou avec la clé **ZO-5** durant cette manipulation.

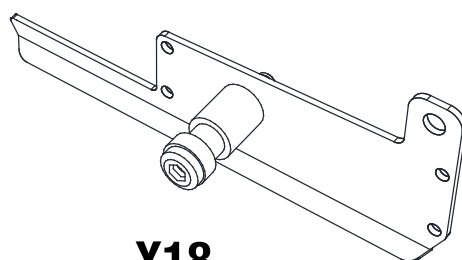
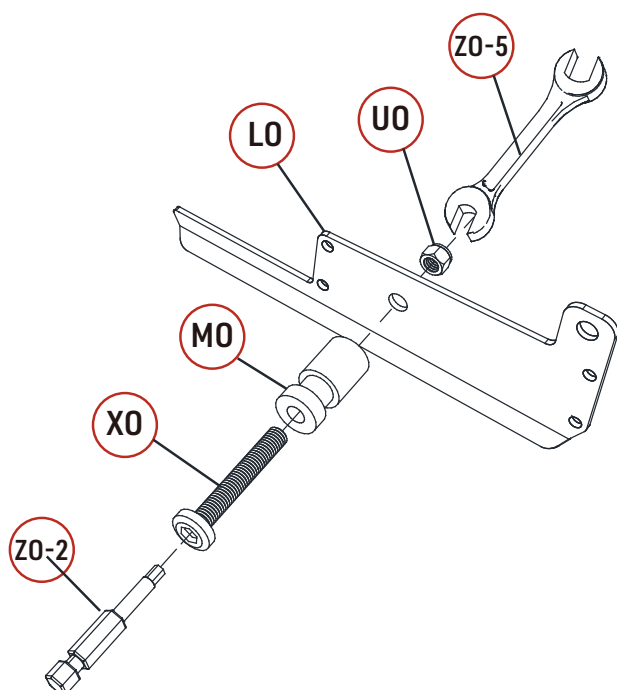
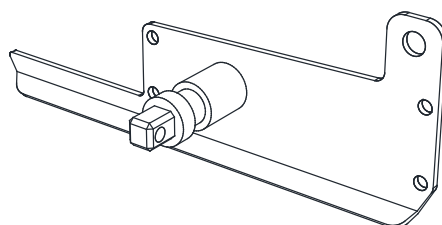

X18

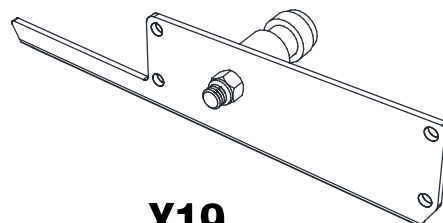
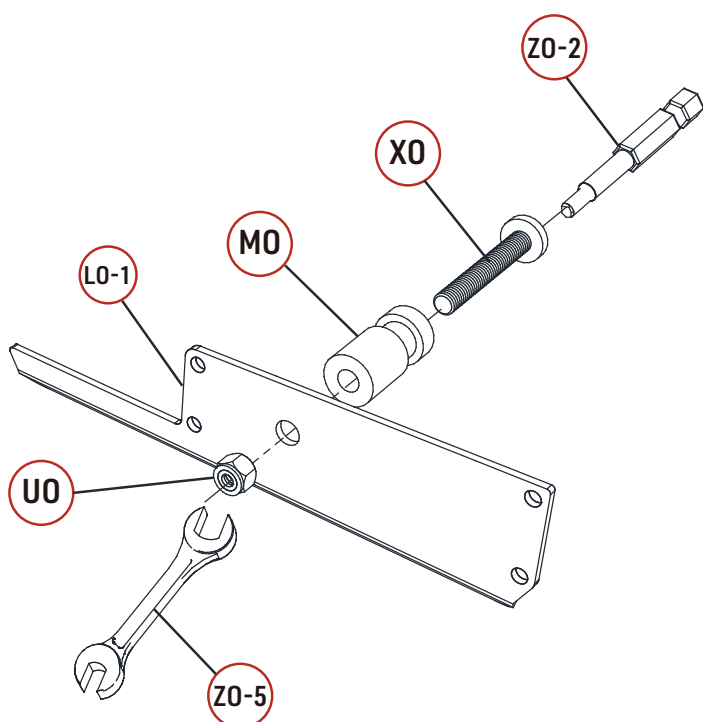

X19

Positionner la lame principale **GO** dans le bon sens comme indiqué sur le schéma, puis fixer le cache lame principal **KO** à droite de la lame et **LO-1** à gauche, avec les vis **WO** à l'aide d'une visseuse et de l'embout T20 **ZO-6**.

X1

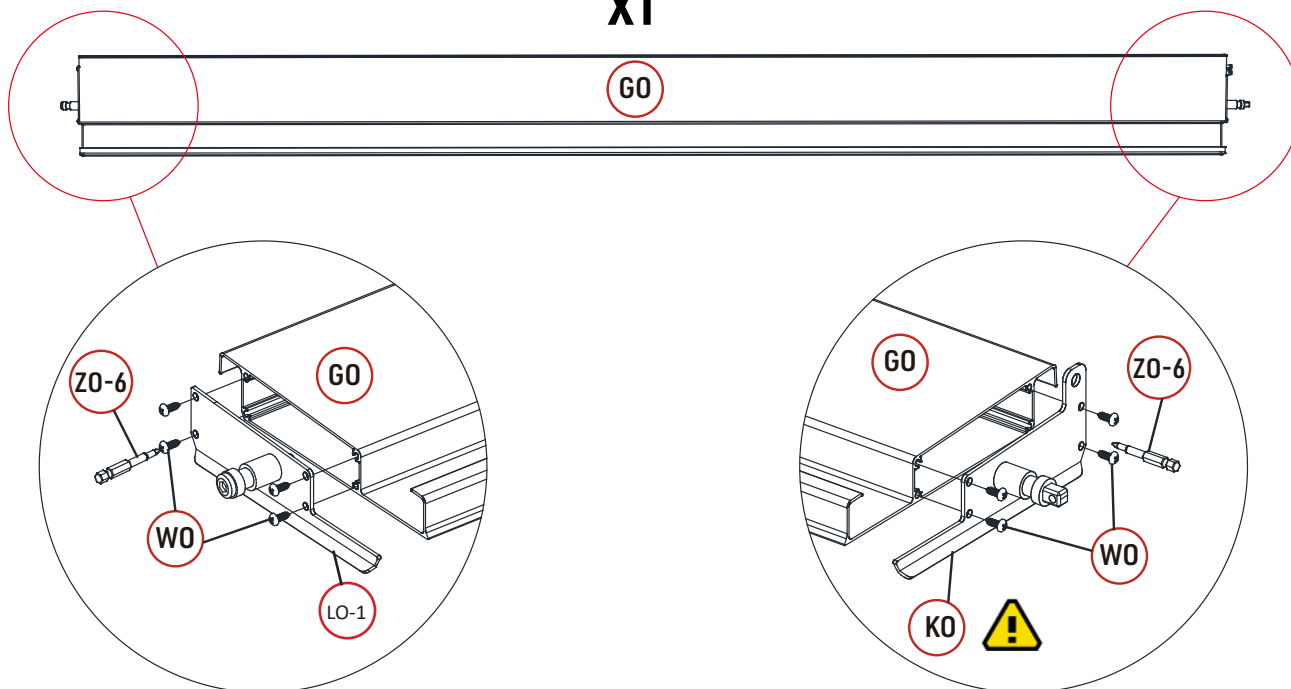

Répéter la même opération avec les autres lames **GO**, en fixant les caches-lame **LO-1** à gauche et **LO** à droite.

X18

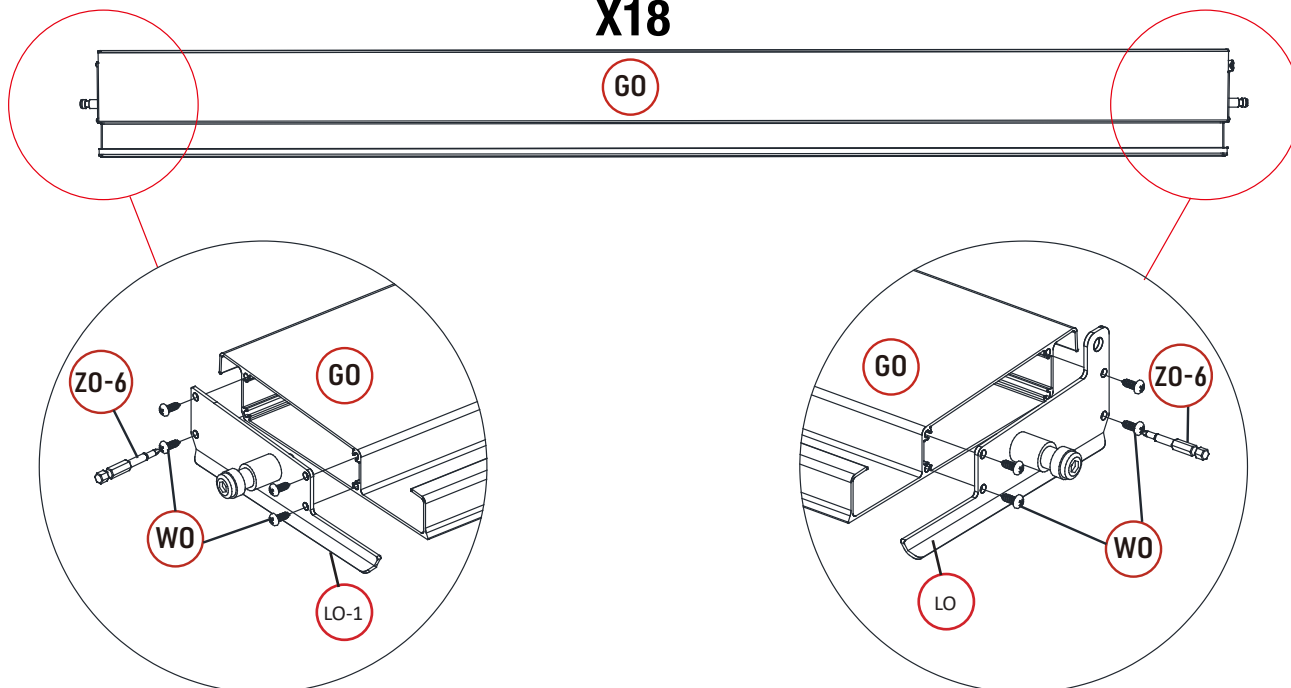

Installer la lame principale en seconde position de l'endroit prévu cet effet sur la pergola, en commençant du côté de la manivelle pour former le toit.

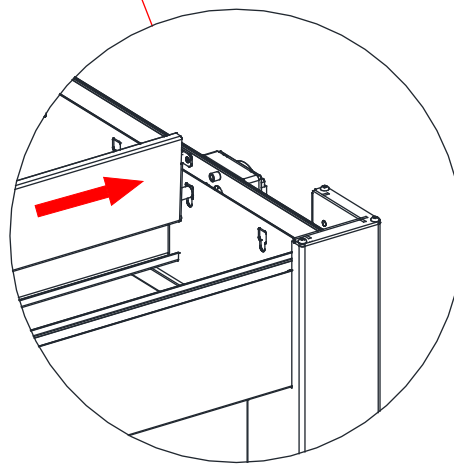
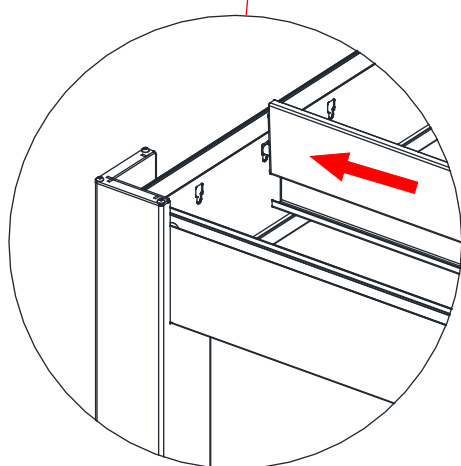
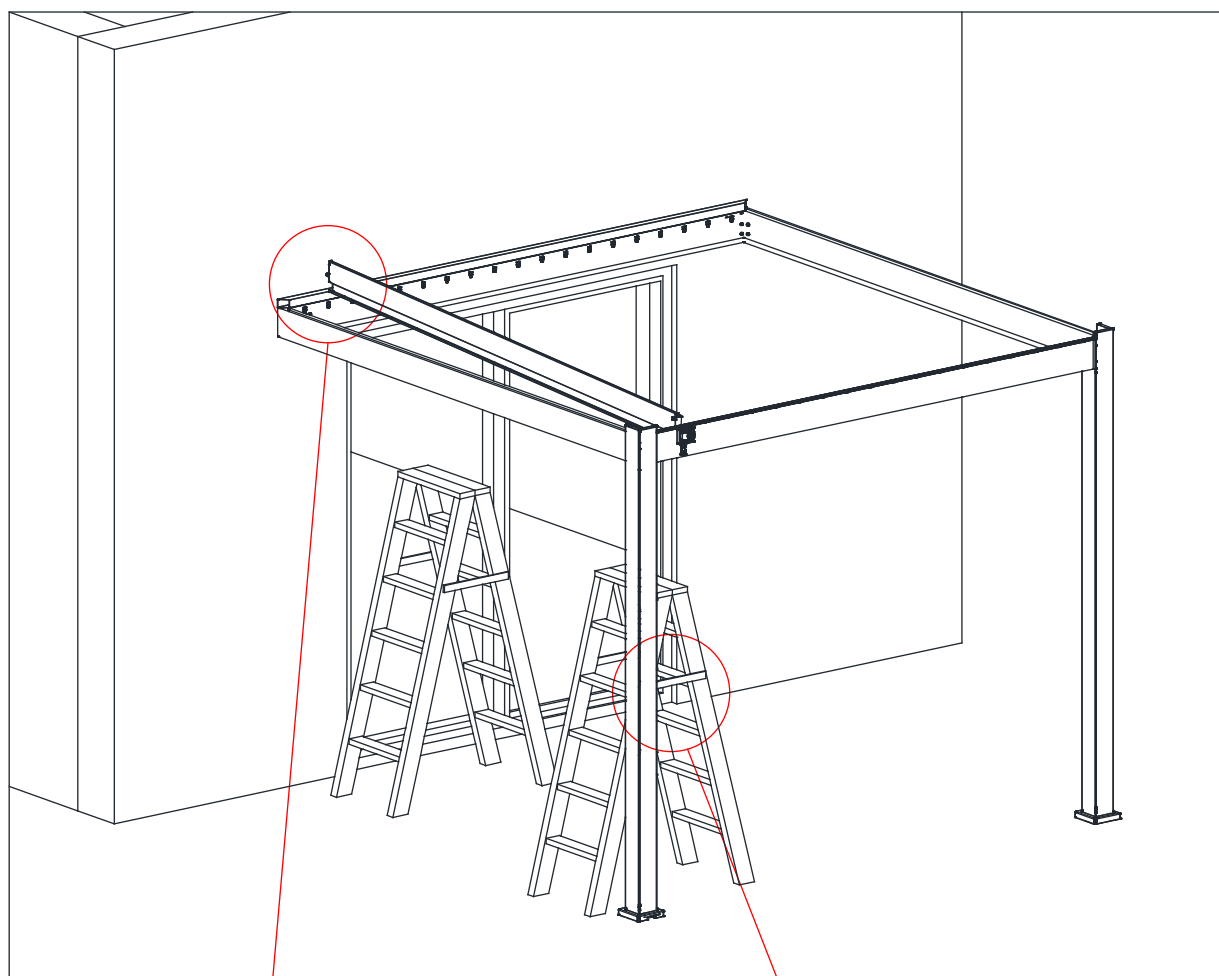

Insérer le cylindre **PO** dans la gearbox et au travers de la poutre, puis pousser jusqu'à emboîtement avec l'ergot de la lame principale.

S'assurer du bon fonctionnement du mécanisme manuel, en faisant une rotation de la lame vers la droite, puis vers la gauche à l'aide de la manivelle **HO**.

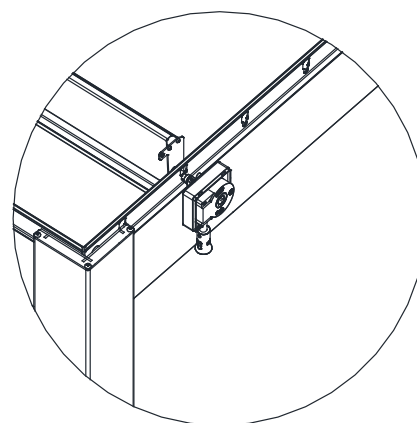
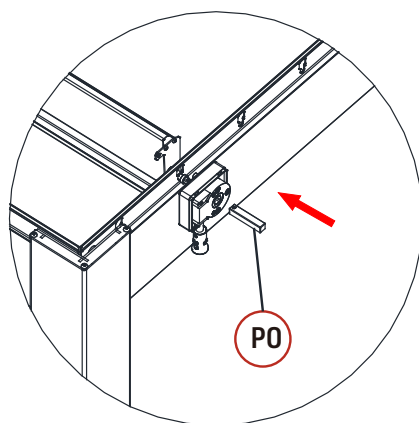
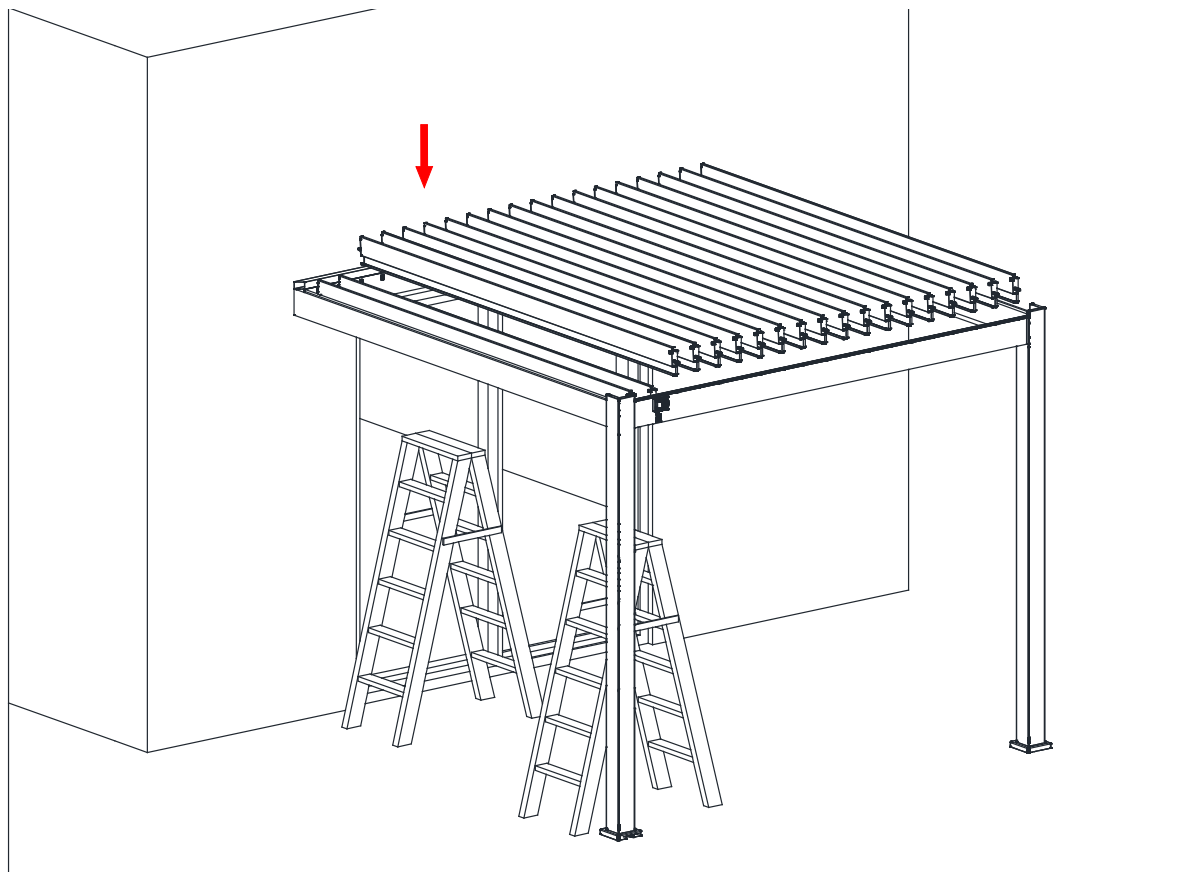

Mettre la lame en position verticale, afin d'installer les autres lames les unes après les autres.

Fixer la barre de connexion **FO** sur toutes les lames avec les rondelles **VO** et les écrous **UO**, à l'aide d'une visseuse et de l'embout T20 **ZO-6** et de la clé **ZO-5** pour maintenir l'écrou.

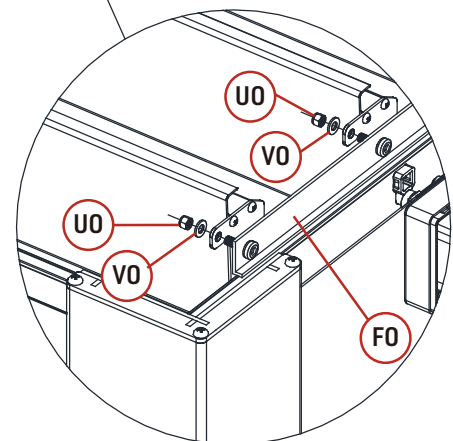
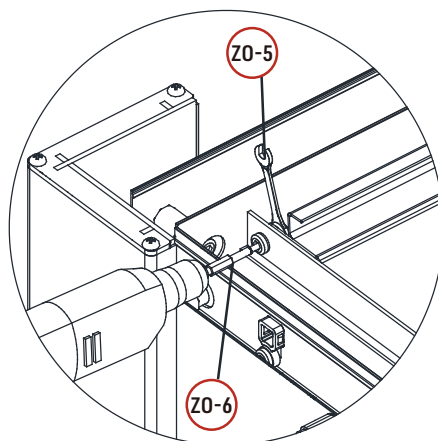
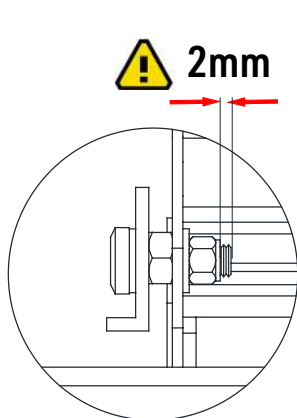
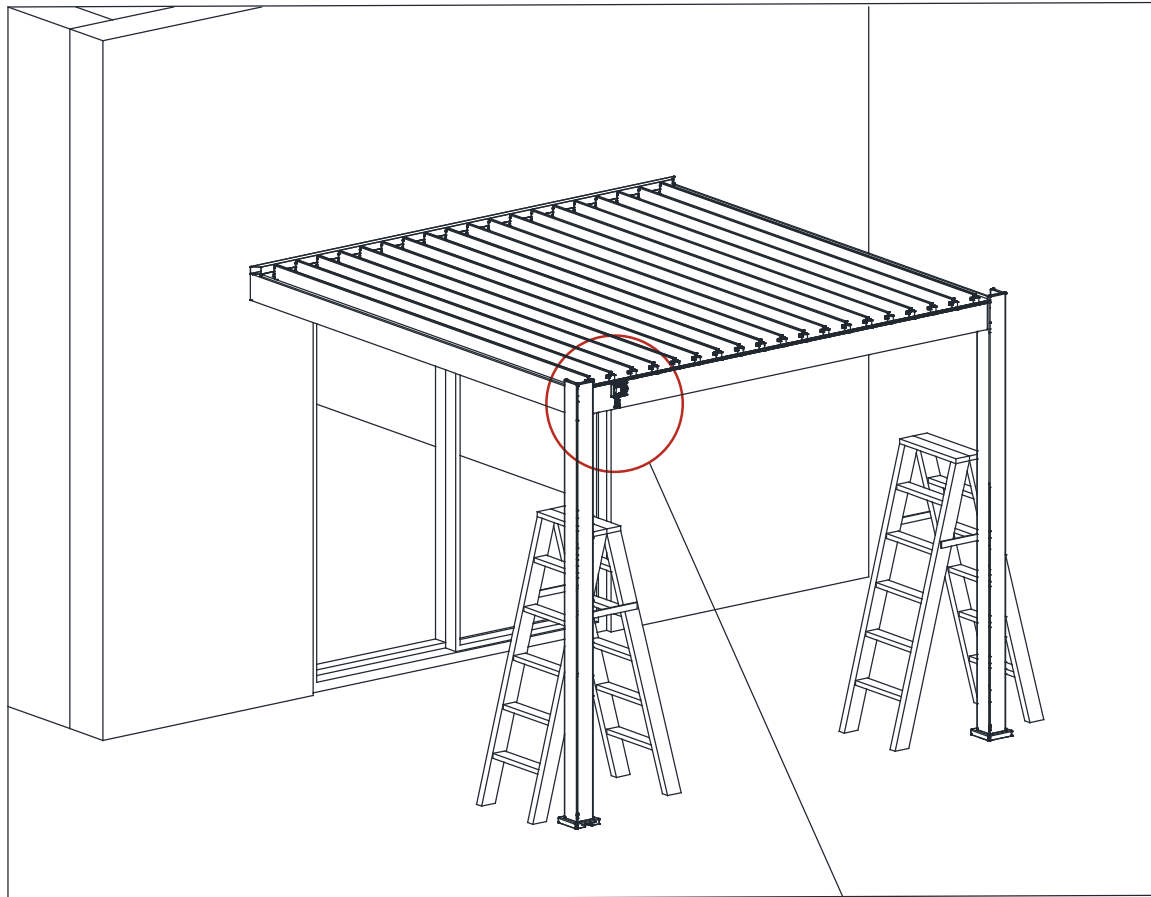

Installer et emboîter les extensions **DO-1**, **DO-3** et **DO-4** sur les poutres comme indiquées sur le schéma.
Puis, insérer les cales demi-lune **SO**. L'ouverture en demi-lune doit se situer sur la partie inférieure de la cale.

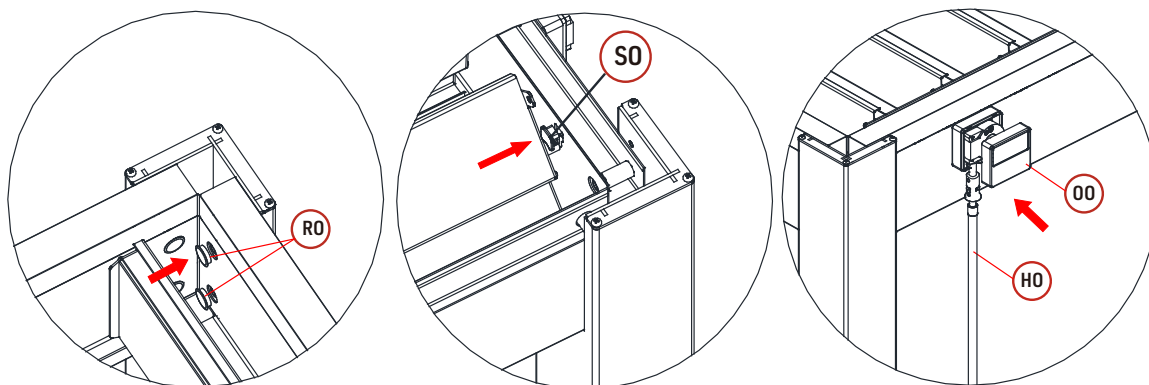
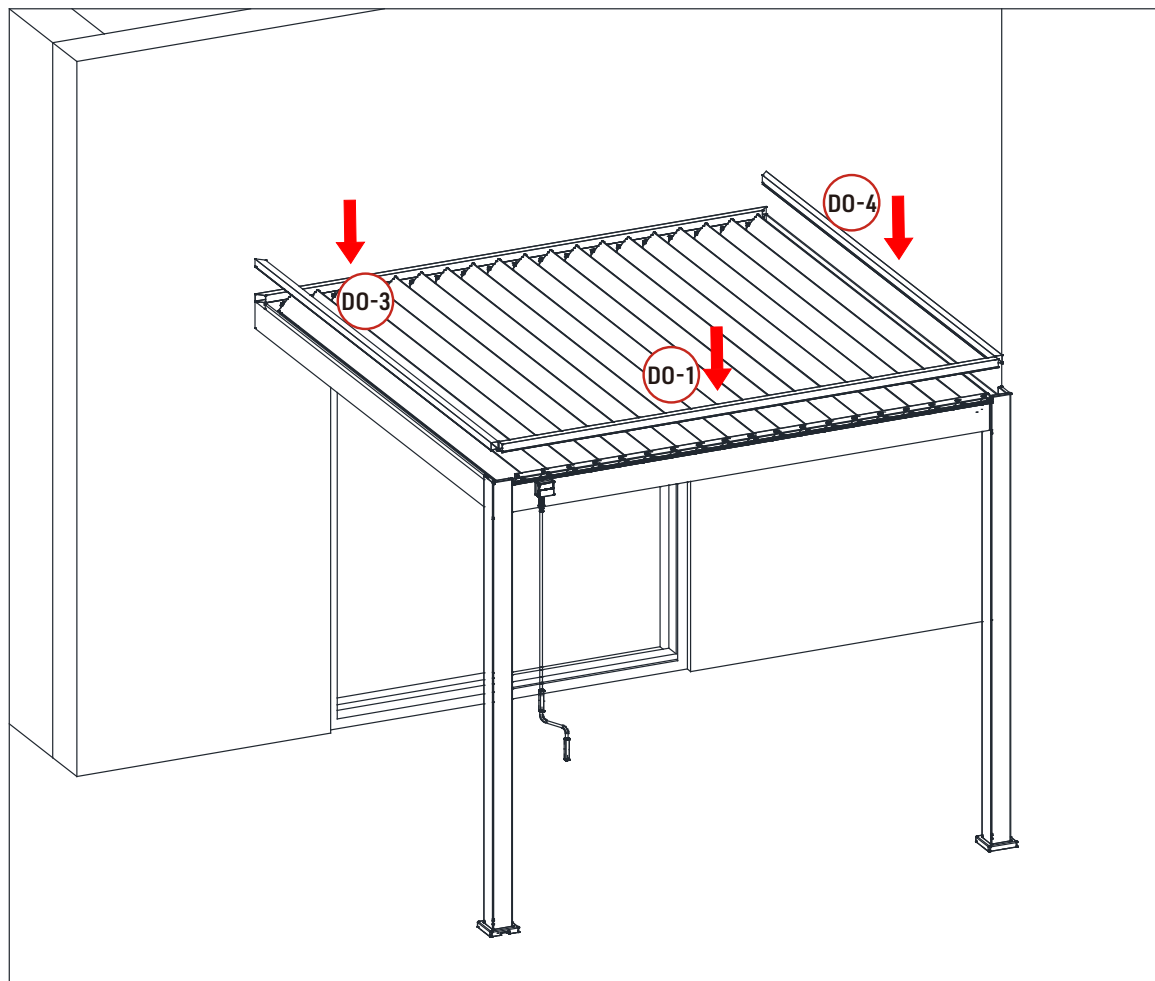

Insérer les boutons de finition **RO** pour masquer les trous situés dans les coins du cadre.
Puis, emboîter la seconde partie du boîtier **OO** pour le refermer et terminer l'installation.

3x3M Wall-mounted louvered pergola

Dark Grey : 15-728981 / **White** : 15-729087

These instructions have to be saved during the whole product life cycle.

We advise you to read these very carefully before proceeding to the assembly.

The user will be reliable for any damages or injuries caused due to incorrect or improper installation.

1. PRECAUTION OF USE

This product should not be used in extreme weather: storms, violent winds, hail, and snow. We guarantee the resistance of the pergola for winds up to 100 km/h and a maximum snow weight of 50kg/m².

As in the case of strong winds or snow, we highly recommend leaving the louvers open. In the case of omission or neglect the pergola will have to be cleared of any snow to avoid any overload on the louvers.

Our pergola can withstand heavy rain, but we cannot guarantee it will be 100% waterproof.

Exceptional climatic events may compromise the perfect sealing of the product. We advise you not to leave products that are sensitive to humidity under the pergola. We do not recommend climbing on the roof or the structure of the pergola, risking damage and may cause injuries.

2. TIPS AND SAFETY INSTRUCTIONS

Depending on the location and surface area, construction may be subject to building permits. Make sure you have checked with your local authorities to obtain the needed information before the assembly.

Product assembly :

- At least 2/3 people required
- Remove protective film (around 1 hour needed)
- Do not keep children near the assembly area
- Beware of the risk of pinching
- Do not tighten the screws before assembling the whole product
- All assembly steps must be carefully followed.
- Check the level of the structure on all sides
- Do not anchor the pergola before assembling the whole product

No changes can be made to the product. Products tampered with by the user are not covered by the warranty, thus being declared as void.

The location should be chosen carefully. It is recommended to avoid mounting your pergola on a rainy day, facing the prevailing winds, and under an overhanging tree.

The pergola must be mounted on a flat-level foundation. It is recommended to install it on a concrete slab or 25x25 cm concrete pads at each post. Please, anchor the pergola properly to the ground using TO parts.

If you would like to mount your pergola near your house or a building, please check the presence of gutters for water drainage.

We cannot guarantee that Ombréa® pergola can ensure perfect sealing if rainwater from your gutter lines spills on it.

Should these instructions not be followed or only partially, the warranty will be voided by the seller.

3. MAINTENANCE

Regular maintenance is necessary to ensure its longevity and aesthetic appearance. We recommend to :

- Clean your pergola once or twice a year with fresh water using a sponge or cloth.
- Do not use detergent or an abrasive material.
- Check the tightness of the screws regularly (at least once a year).
- Oil fastening regularly (at least once a year).
- Make sure that nothing hinders the water flow in the gutters (leaves, branches...).
- Remove any water that might stagnate around the legs of the pergola (lift the posts skirts).

4. WARRANTY

Ombrea® guarantees the availability of the spare parts for 2 or 5 years (depending on the product). It only applies if the storage, assembly, use and maintenance instructions are respected.

This warranty does not cover :

- Normal wear and tear inherent from the products.
- Loss or breakage of any part during unpacking or installation.
- Lack of care, neglect, vandalism, impact with foreign body, force, contact with abrasives material, product aesthetics, disassembly, rebuilding or relocation.
- Force majeure: hail, high winds, storms, snow, floods, lightning etc...
- Product tampered with by the user.

The warranty only takes in account the replacement of spare parts or the provided product, no refund will be issued.

All warranty claims must be made at the sales outlet (store or website) where the product has been purchased.

5. PARTS LISTS (PER CARTON)



Before proceeding with the assembly of your louvered pergola, it is necessary to check that all parts listed are supplied and not damaged.

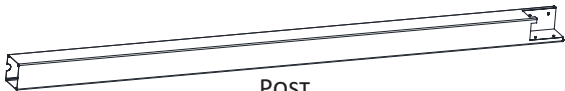

Any missing part must be reported within 10 days of delivery. You can either go through your local outlet store or make the request directly on our website sav.comintes.com.

Do not discard the packaging without ensuring that the product is functioning properly.

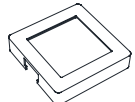

CARTON 1/4 (POSTS AND LOOSE PARTS)

| Reference | Parts | Quantity |
|-----------|--|----------|
| AO |  POST | 2 |



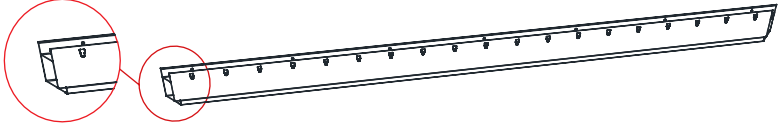
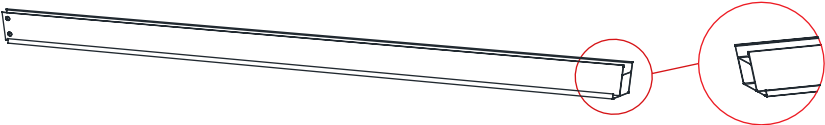

| Reference | Parts | Quantity |
|-----------|--|----------|
| IO |  POST SKIRT | 2 |
| JO |  POST BASE PLATE | 2 |







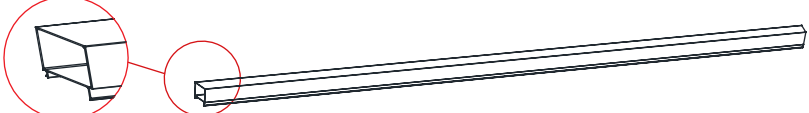



| Reference | Parts | Quantity |
|-----------|---|----------|
| TO |  M8x80 CONCRETE EXPANSION ANCHOR BOLT | 8 |
| XO-1 |  6x35 BOLT 6X35 | 8 |

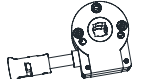

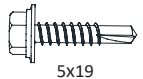
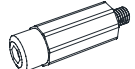

CARTON 2/4 (BEAMS AND LOOSE PARTS)



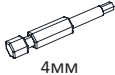

| Reference | Parts | Quantity |
|-----------|---|----------|
| BO-1 |  MAIN BEAM | 1 |
| BO-2 |  BACK BEAM | 1 |
| CO-1 |  SIDE BEAM (LEFT) | 1 |
| CO-2 |  SIDE BEAM (RIGHT) | 1 |

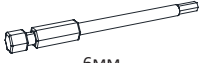
CARTON 2/4 (BEAMS AND LOOSE PARTS)

| Reference | Parts | Quantity |
|-----------|--|----------|
| DO-1 |  BEAM EXTENSION (FRONT) | 1 |
| DO-2 |  BEAM EXTENSION (BACK) | 1 |
| DO-3 |  BEAM EXTENSION (LEFT) | 1 |
| DO-4 |  BEAM EXTENSION (RIGHT) | 1 |
| FO |  CONNECTOR BAR | 1 |
| HO |  CRANK HANDLE | 1 |

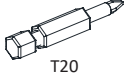
| Reference | Parts | Quantity | Reference | Parts | Quantity |
|-----------|--|----------|-----------|---|----------|
| LO-2 |  PLASTIC CORNER | 2 | UO |  NUT | 56 |
| NO |  GEARBOX | 1 | VO |  WASHER | 19 |
| OO |  BOX COVER | 1 | XO |  6x40 BOLT 6x40 | 37 |
| PO |  CYLINDER | 1 | XO-2 |  5x19 SELF-DRILLING SCREW 5X19 | 8 |
| QO |  BEAM FIXING SCREW | 8 | YO |  6x45 BOLT 6x45 | 3 |
| RO |  CIRCLE CAP | 8 | ZO-1 |  4MM 4MM ALLEN KEY | 1 |
| SO |  HALF MOON PLASTIC CAP | 38 | | | |



| Reference | Parts | Quantity |
|-----------|---|----------|
| ZO-2 |  4MM 4MM HEX BIT | 1 |
| ZO-3 |  6MM 6MM ALLEN KEY | 1 |
| ZO-4 |  6MM 6MM HEX BIT | 1 |
| ZO-5 |  10MM 10MM FLAT WRENCH | 1 |

| Reference | Parts | Quantity |
|-----------|--|----------|
| ZO-6 |  T20 T20 TORX BIT | 1 |
| ZO-7 |  DRIVER BIT | 1 |
| ZO-8 |  GLUE | 1 |
| TO-1 |  ANCHOR 8X100 | 1 |

CARTON 3/4 (LOUVERS AND LOOSE PARTS)

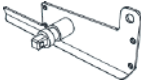
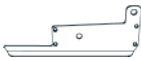
| Reference | Parts | Quantity |
|-----------|---|----------|
| GO |  LOUVER | 9 |

| Reference | Parts | Quantity |
|-----------|--|----------|
| KO |  MAIN LOUVER END CAP | 1 |
| LO |  A LOUVER END CAP | 18 |

| Reference | Parts | Quantity |
|-----------|---|----------|
| LO-1 |  B LOUVER END CAP | 19 |
| MO |  SPRING PIN | 37 |

| Reference | Parts | Quantity |
|-----------|---|----------|
| WO |  4x16 SCREW 4X16 | 152 |

CARTON 4/4 (LOUVERS)

| Reference | Parts | Quantity |
|-----------|--|----------|
| GO |  LOUVER | 10 |

The parts from aluminium are AO, BO-1, BO-2, CO-1, CO-2, DO-1, DO-2 DO-3, DO-4, FO, GO, IO, KO, LO et LO1.

Screws, bolts, and other loose parts are either from stainless steel, galvanized steel, nylon, or plastic.

For any further information, make sure to refer to the technical specifications of the product and consult our FAQ page on the website www.pergola-ombrea.com or contact your outlet store.

6. NECESSARY TOOLS AND SAFETY GEAR (NOT SUPPLIED)



Safety glasses and
Work gloves



2 Ladders



Electric drill + 12mm
concrete drill bit



Electric screwdriver

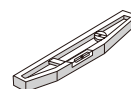

Spirit level



Cutter



Safety Helmet

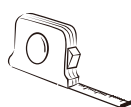

Tape measure



Glue

7. CONTACT

We gladly welcome feedback and suggestions from our clients in order to help us improve our services by email: contact@pergola-ombrea.com

We would be grateful to receive pictures of your installation.

We would like to thank you for your purchase and wish you happy days under your new brand Ombrea pergola !

8. FOOTING MEASUREMENT (dimensions in mm)

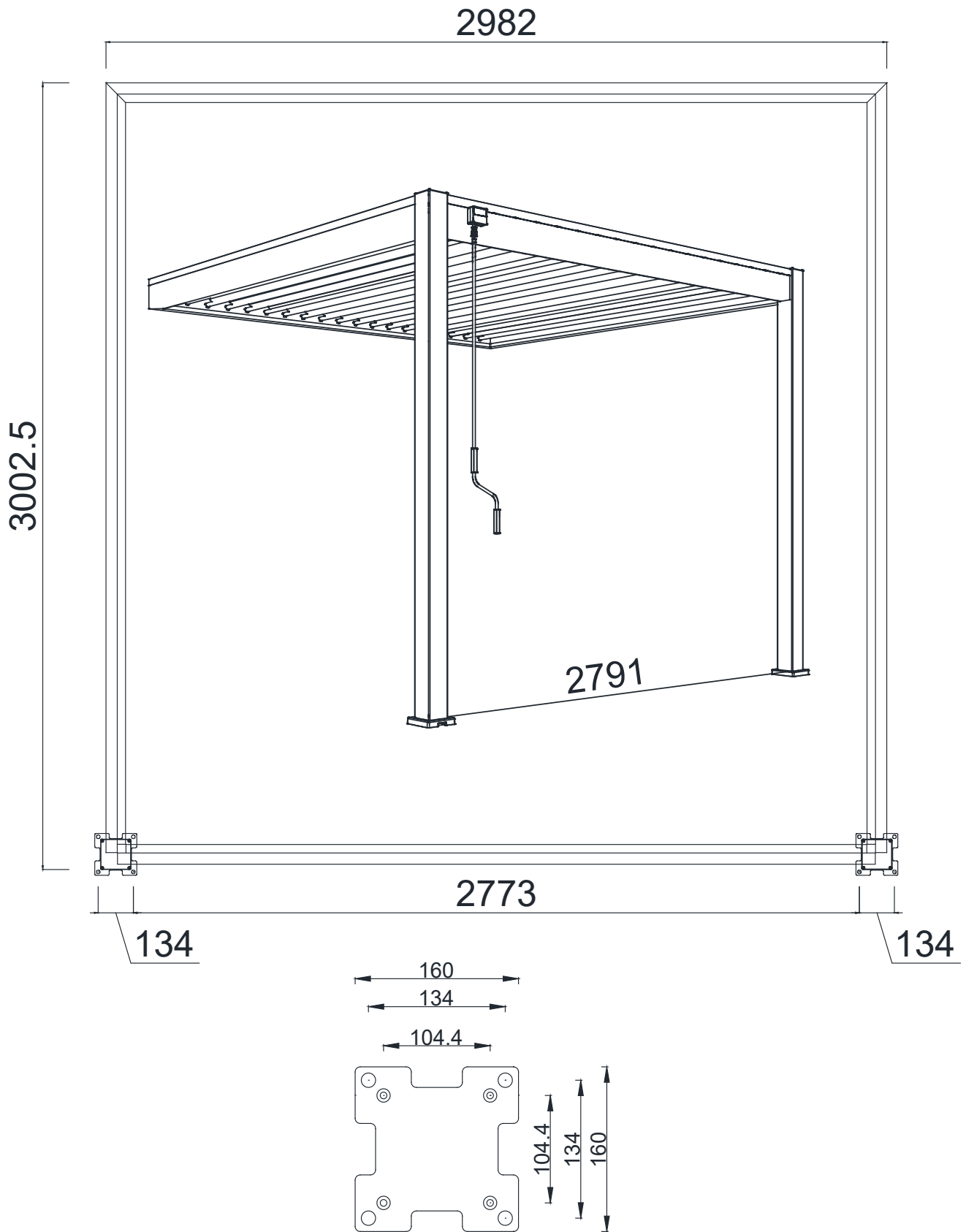

9. ASSEMBLY GUIDELINES

To prevent any damage to your pergola, we recommend to place the parts either on a table, trestles or a smooth and clean surface.

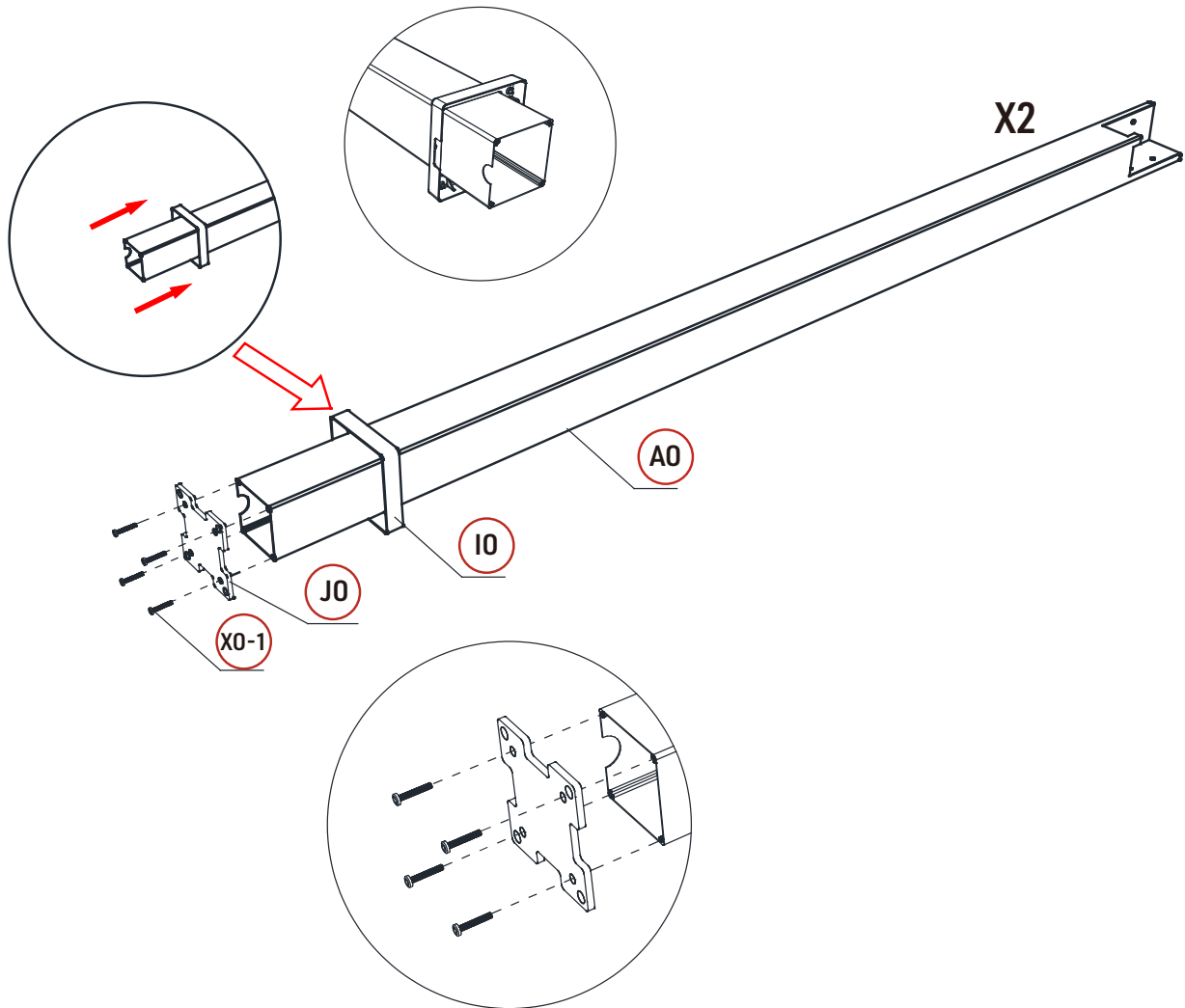

Insert and slide the post skirts **IO** onto the posts **AO**. The opening of this part should stay on the same side as the crescent opening located on the bottom of the post.

Fasten the post base plate **JO** with the bolt **XO-1** by using an electric screwdriver.

Remove **DO-1**, **DO-2**, **DO-3** and **DO-4** beam extension from the beams **BO-1**, **BO-2**, **CO-1** and **CO-2**.
Keep for later.

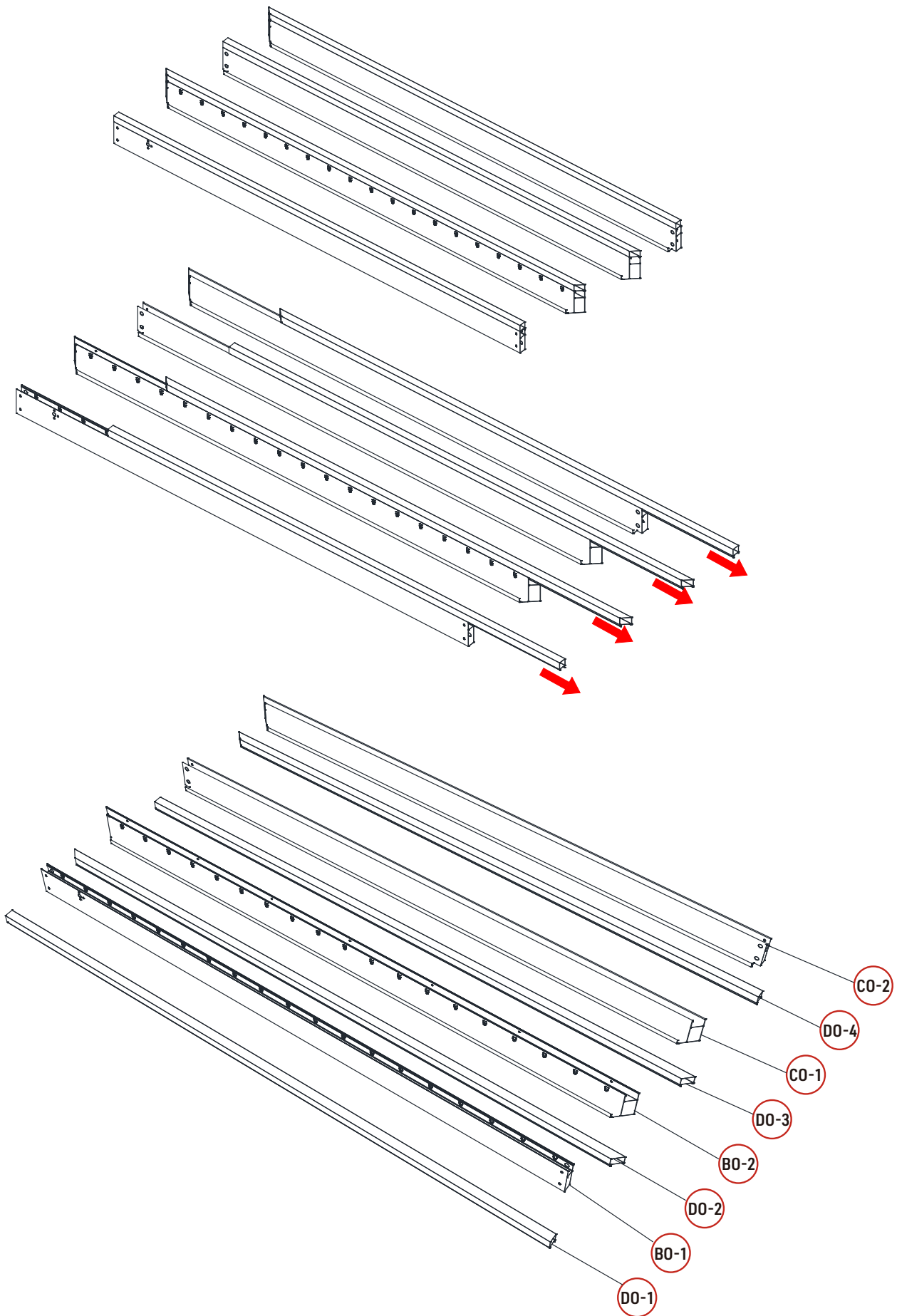

Insert the plastic corner **LO-2** into the wall beam **BO-2**, then fasten as shown in the drawing with the self-drilling screws **XO-2**, using an electric screwdriver with the drill bit **ZO-7**.

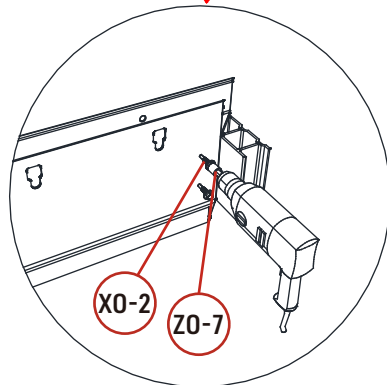
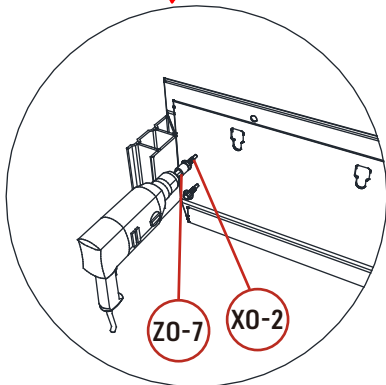
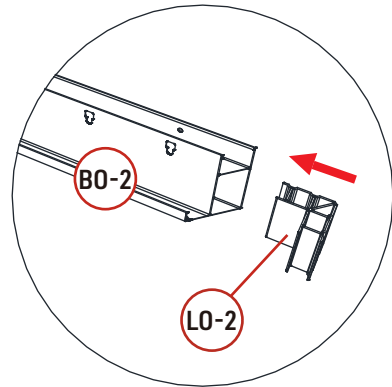
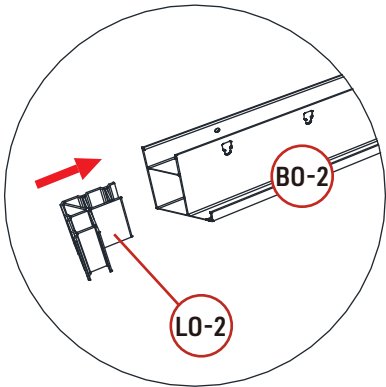

On a flat wall, place the wall beam **BO-2** at a height of 237 cm.

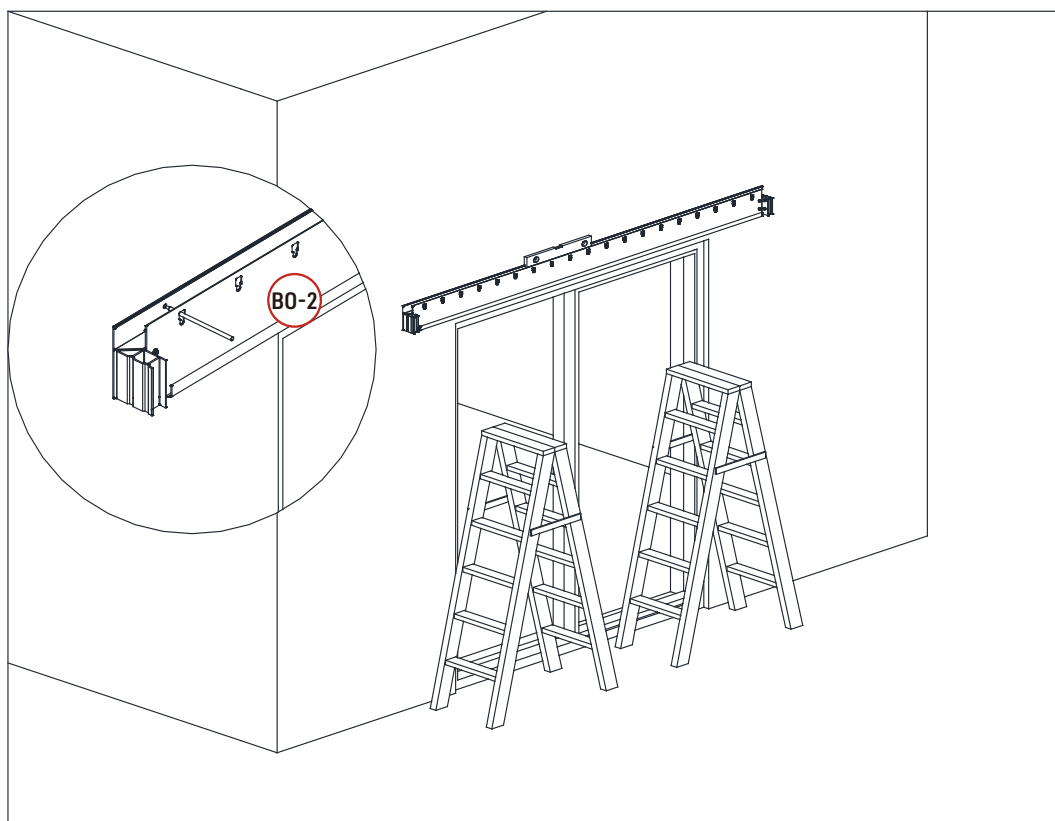
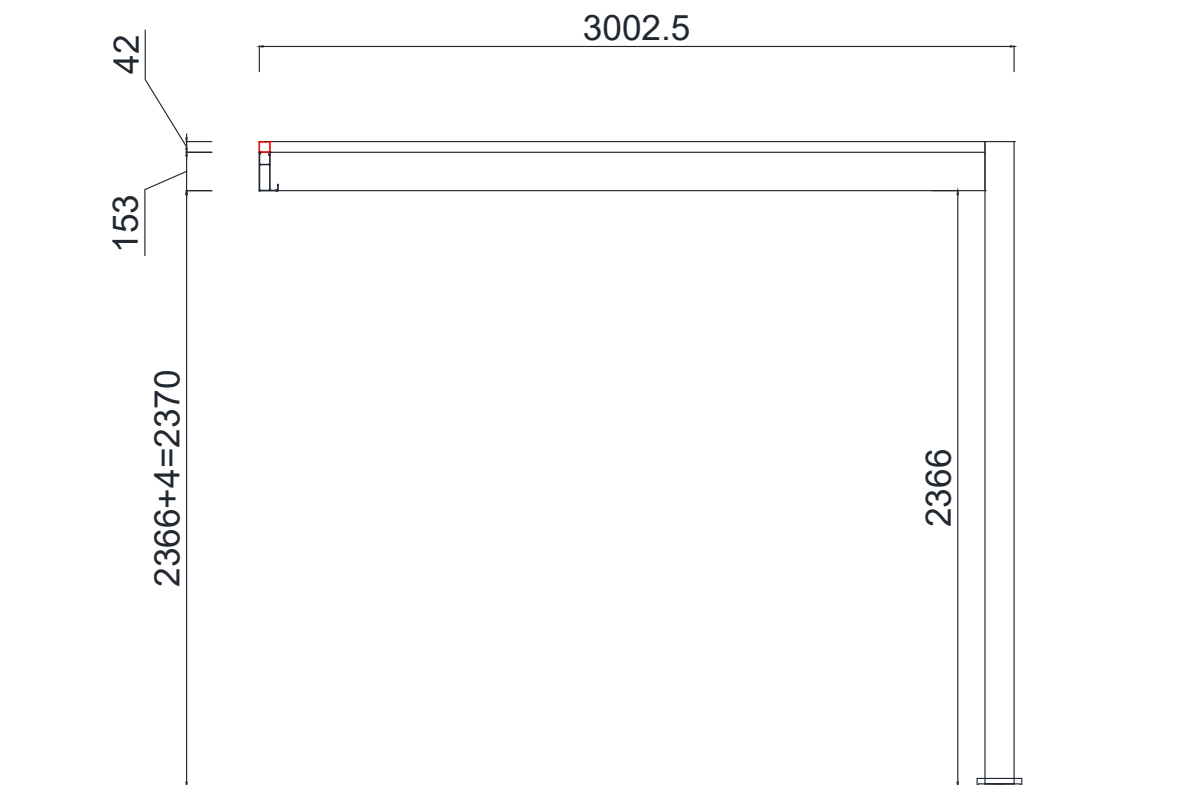

Together with at least 2/3 people, using a spirit level make sure the wall beam **BO-2** is parallel to the ground and mark the mounting hole with a pen before removing it.

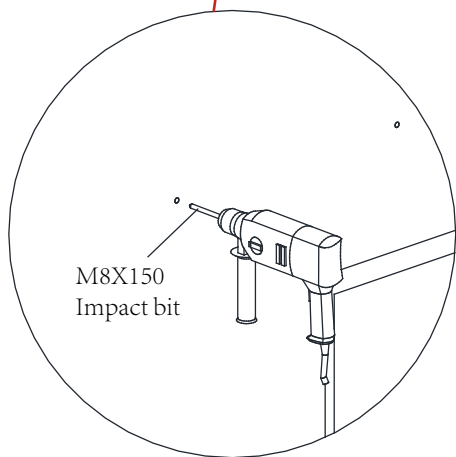
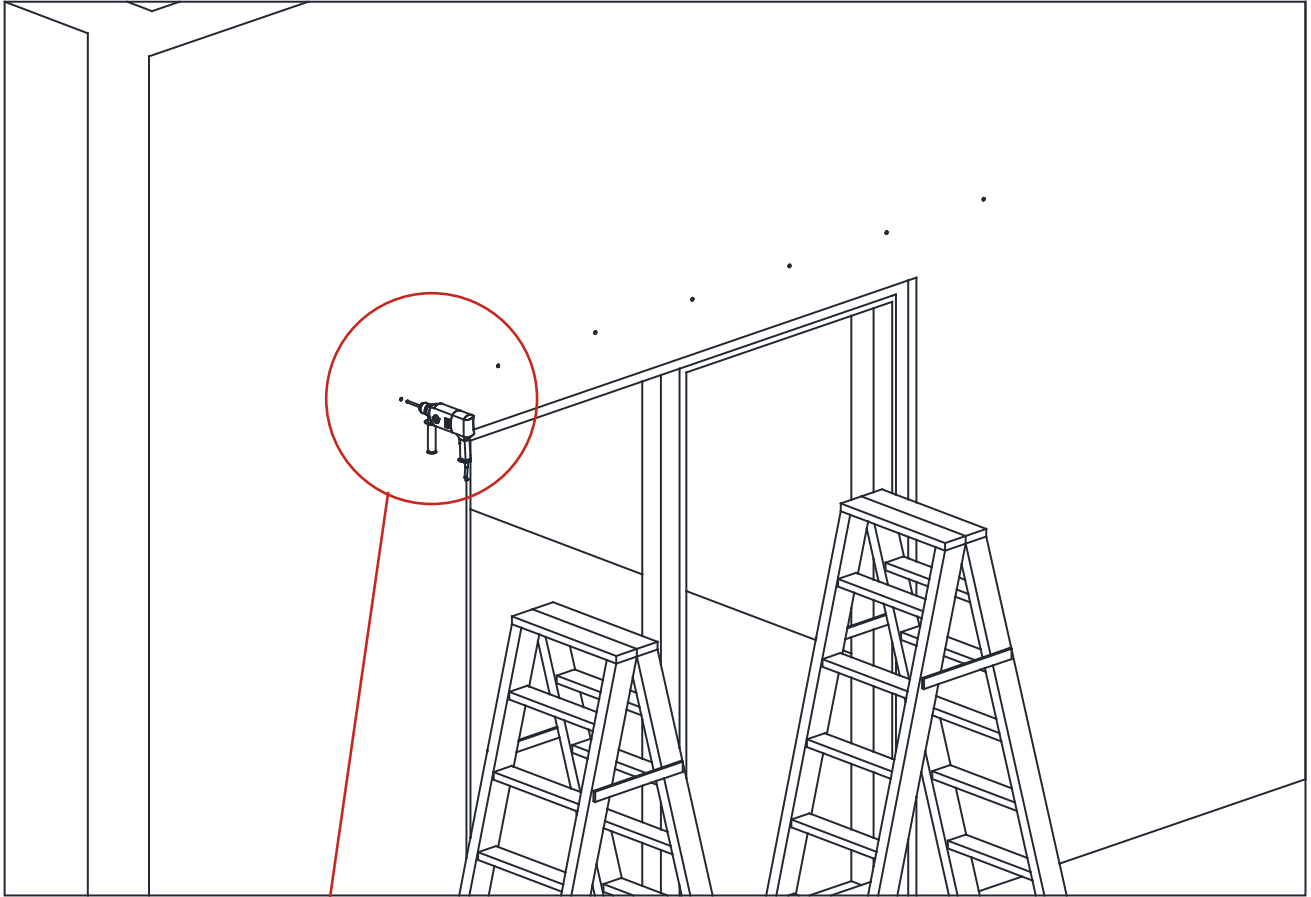

Using an electric drill with a M8x150 drill bit, make holes in the marked area.

Tips: for maximum watertightness, prepare a glue gun (not supplied) and apply the glue between the wall and the wall beam.

Replace the wall beam **BO-2** and keep it level parallel to the ground. Then, drive the anchors **TO-1** as shown in the drawing.

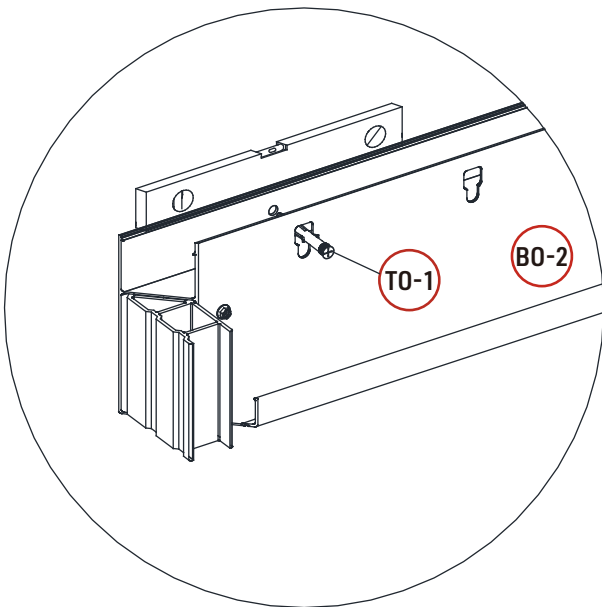
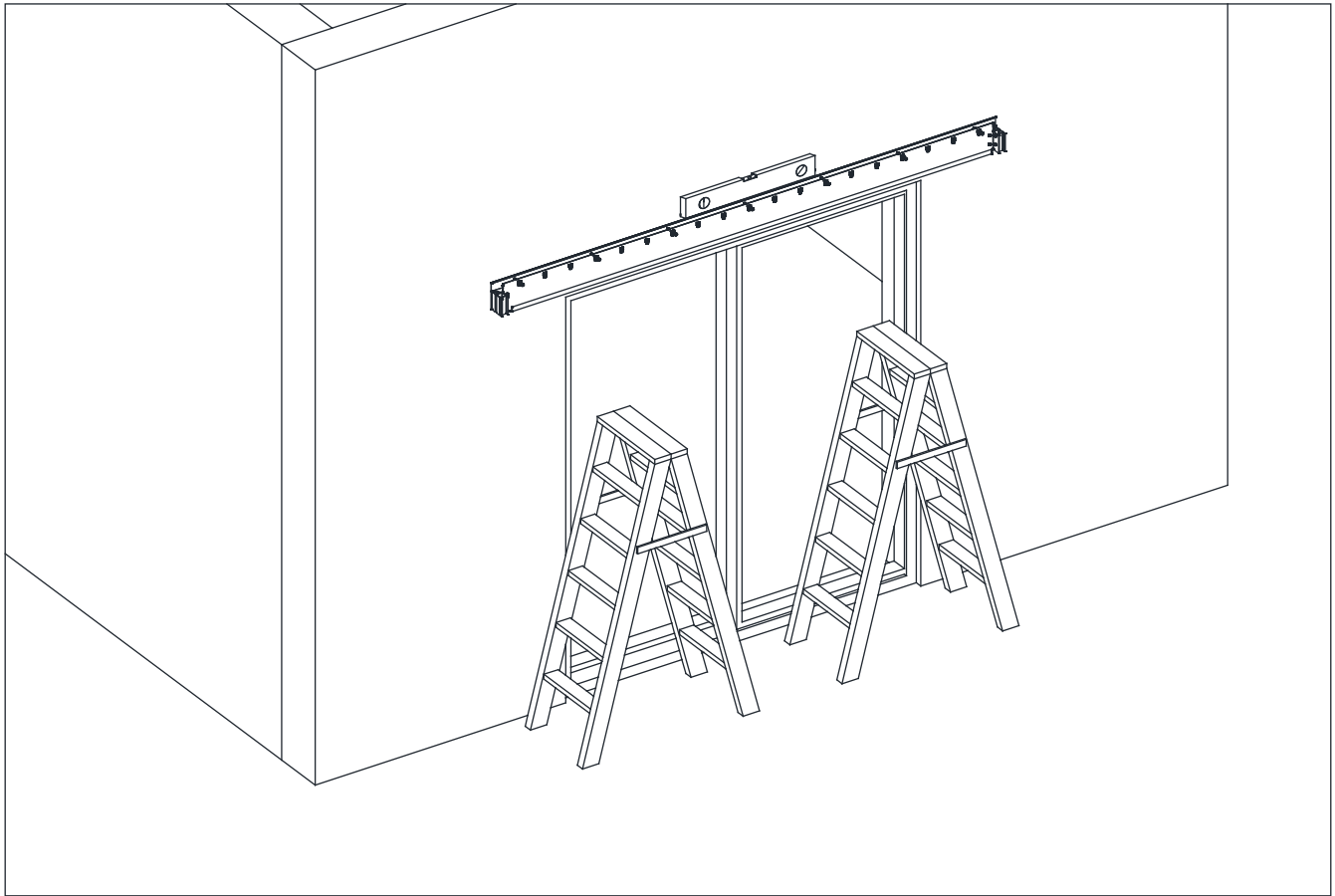

Clip on the beam extension **DO-2** onto the wall beam **BO-2**.

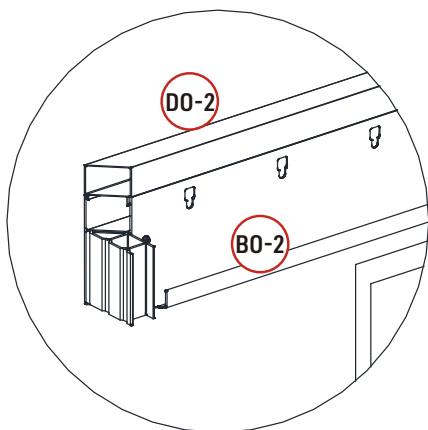
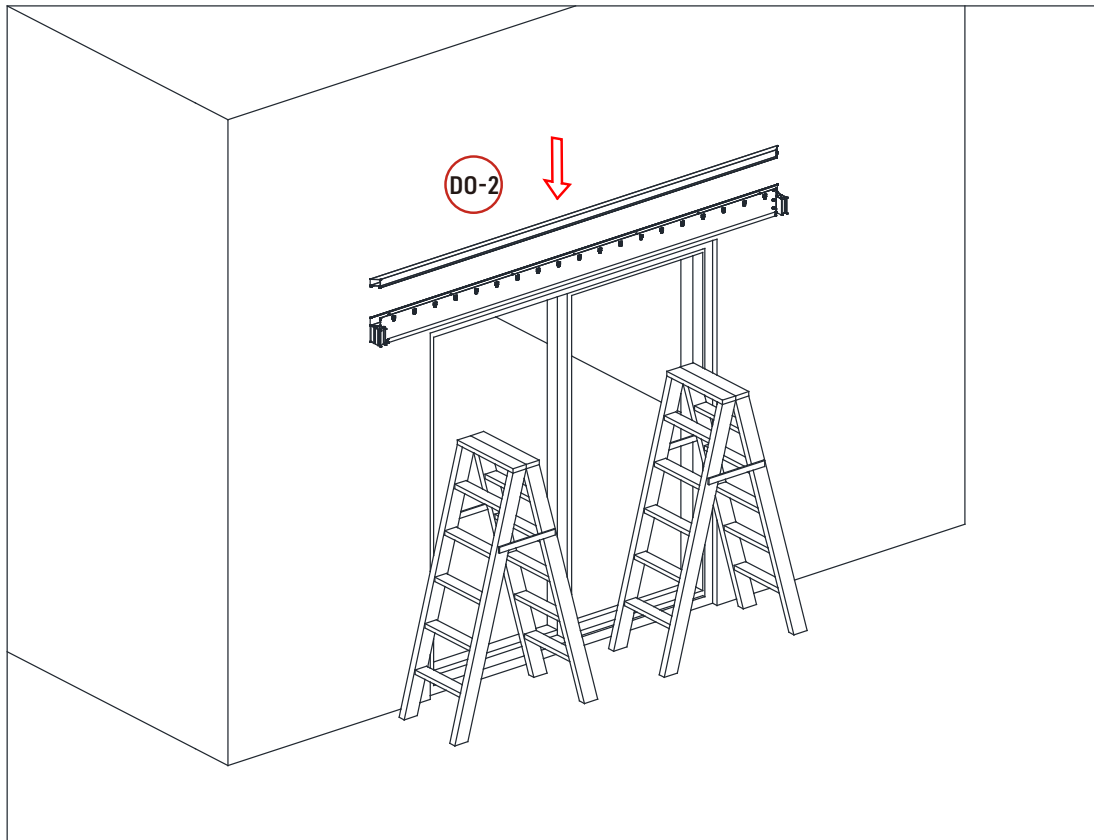

Fasten the beams **CO-1** and **CO-2** onto the posts **AO** with the screws **QO** using an electric screwdriver and the hex bit **ZO-4** or the Allen Key **ZO-3** as shown in the drawing.
Then, connect the set onto the wall beam **BO-2** by the parts **LO-2**.

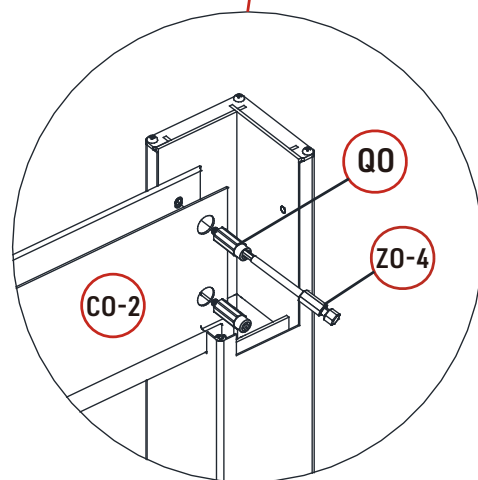
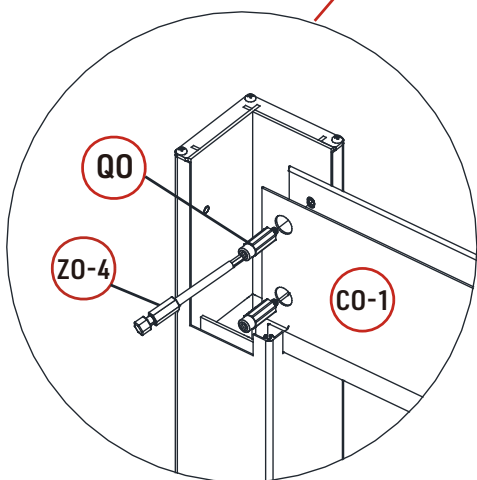
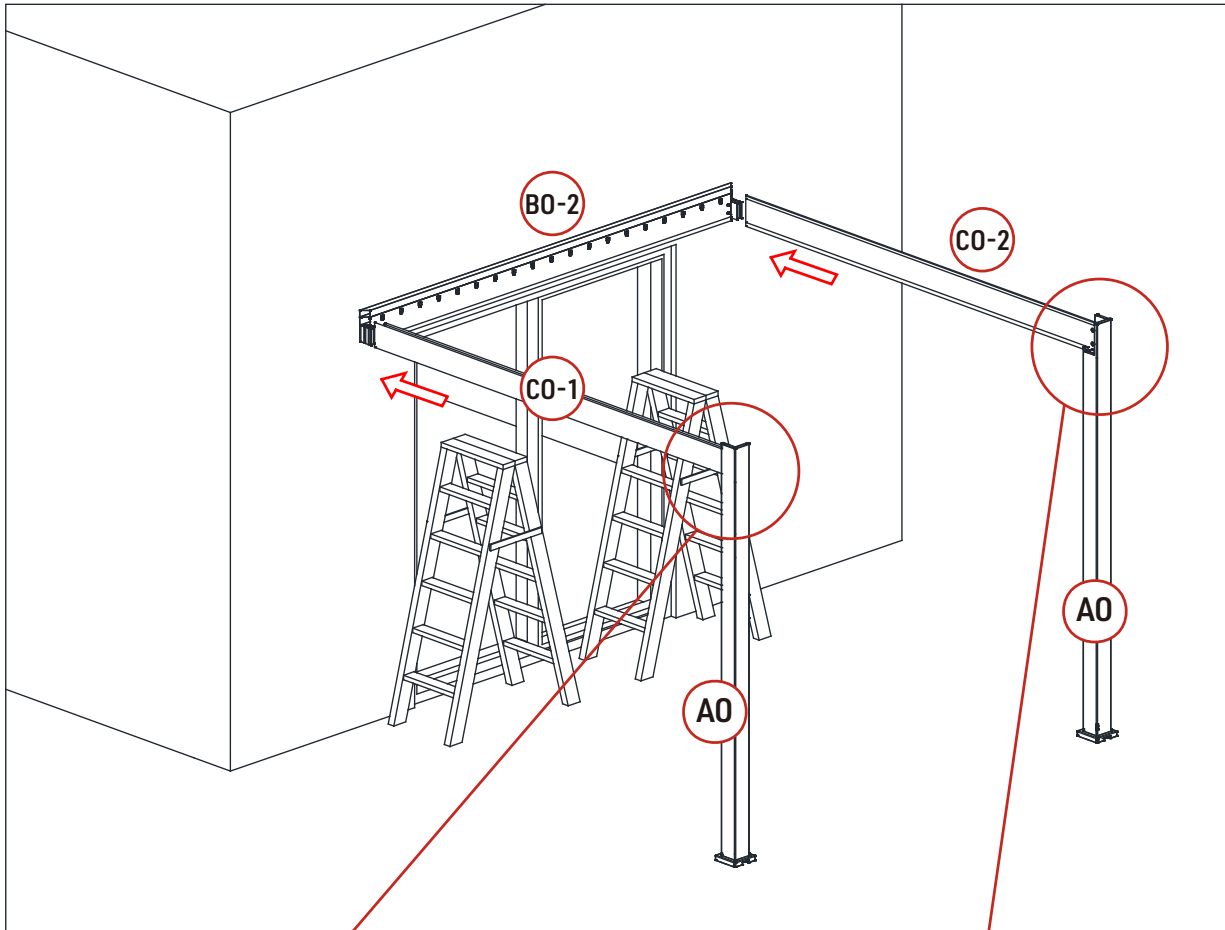

Fasten the side beams **CO-1** and **CO-2** to the part **LO-2** with the self-drilling screws **XO-2**, as shown in the drawing using an electric screwdriver and the drill bit **ZO-7**.

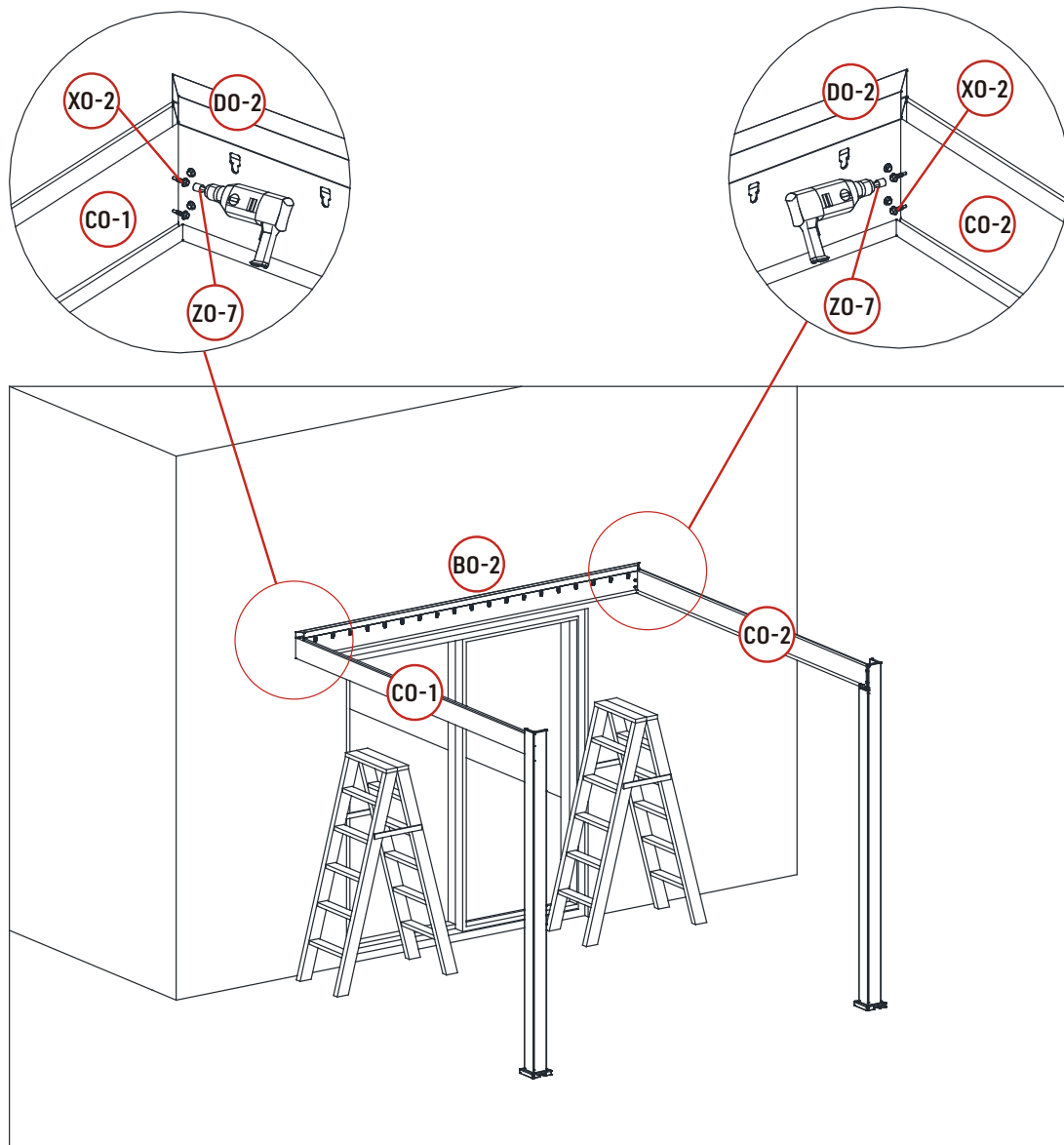

Apply some glue **ZO-8** by both corners for maximum watertightness as shown in the drawing.

Then, to close the frame, fasten the front beam **BO-1** onto the post **AO** with the screws **QO**, using an electric screwdriver with the hex bit **ZO-4** or the Allen key **ZO-3**.

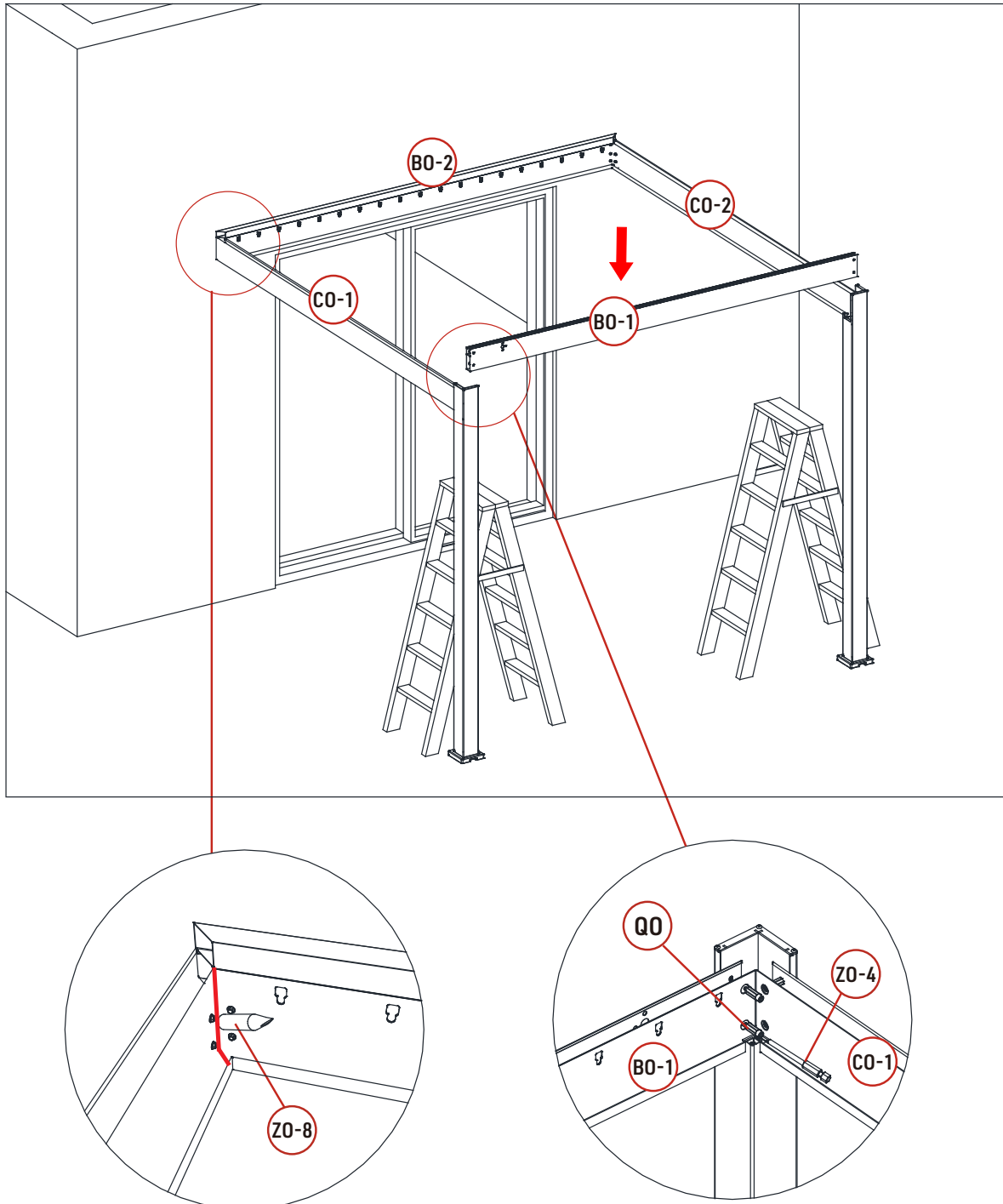

Combine and fasten the first part of the box **OO** with the Gearbox **NO** onto the beam **BO-1** with the bolts **YO**, using the Allen key **ZO-3** or a screwdriver and the hex bit **ZO-4**.

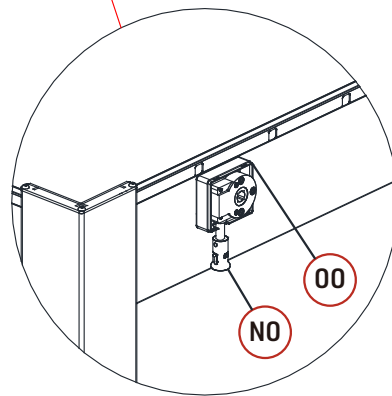
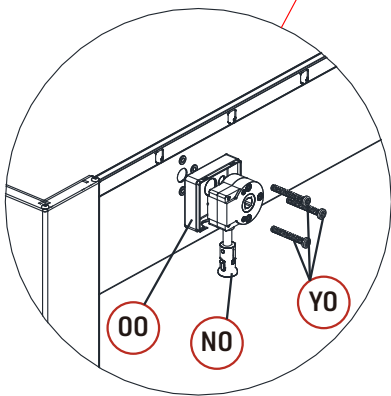
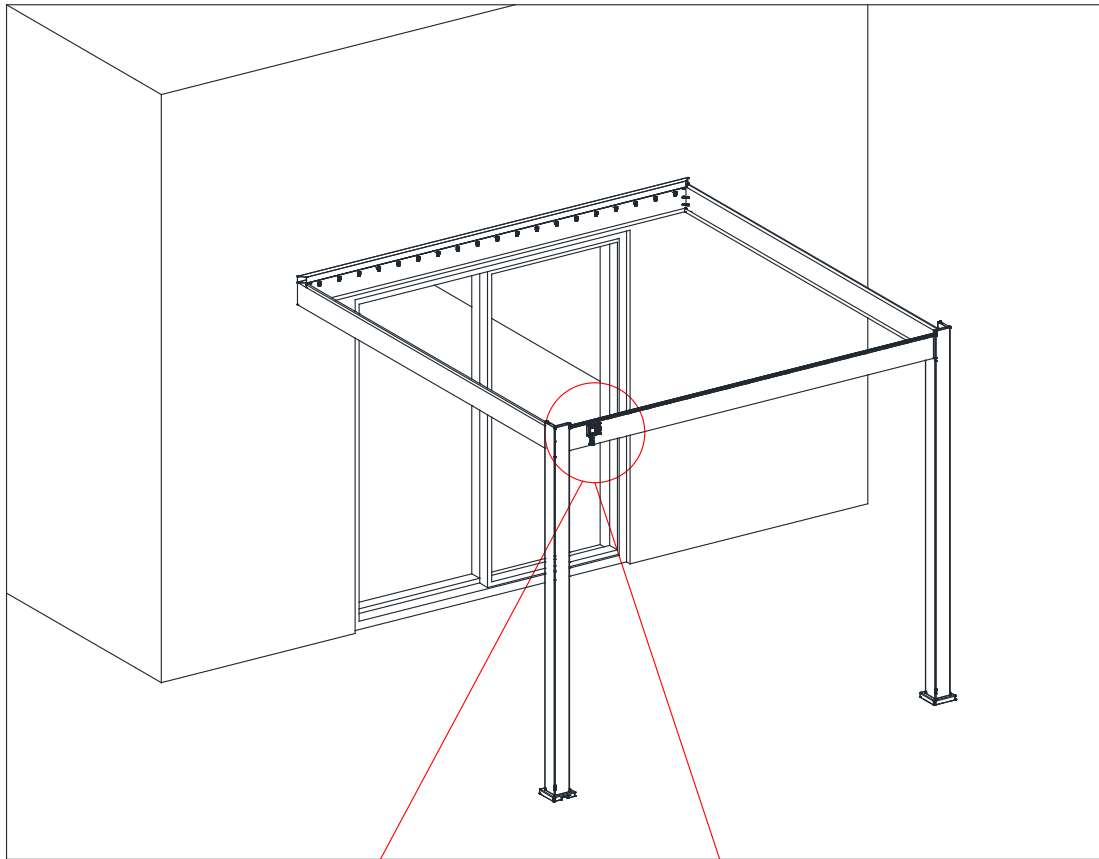

Anchor the pergola on a hard and flat concrete floor with the concrete expansion anchor bolts **TO**, using an electric drill and the 12mm Drill bit (not supplied).

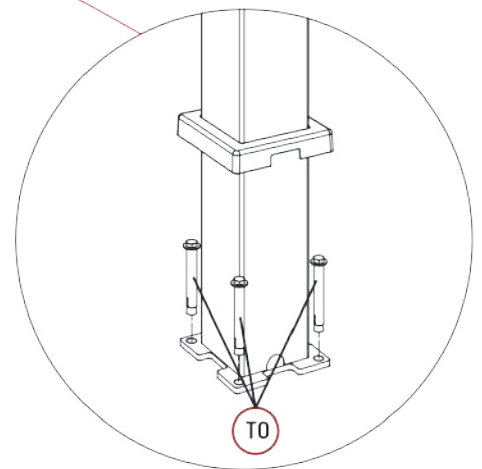
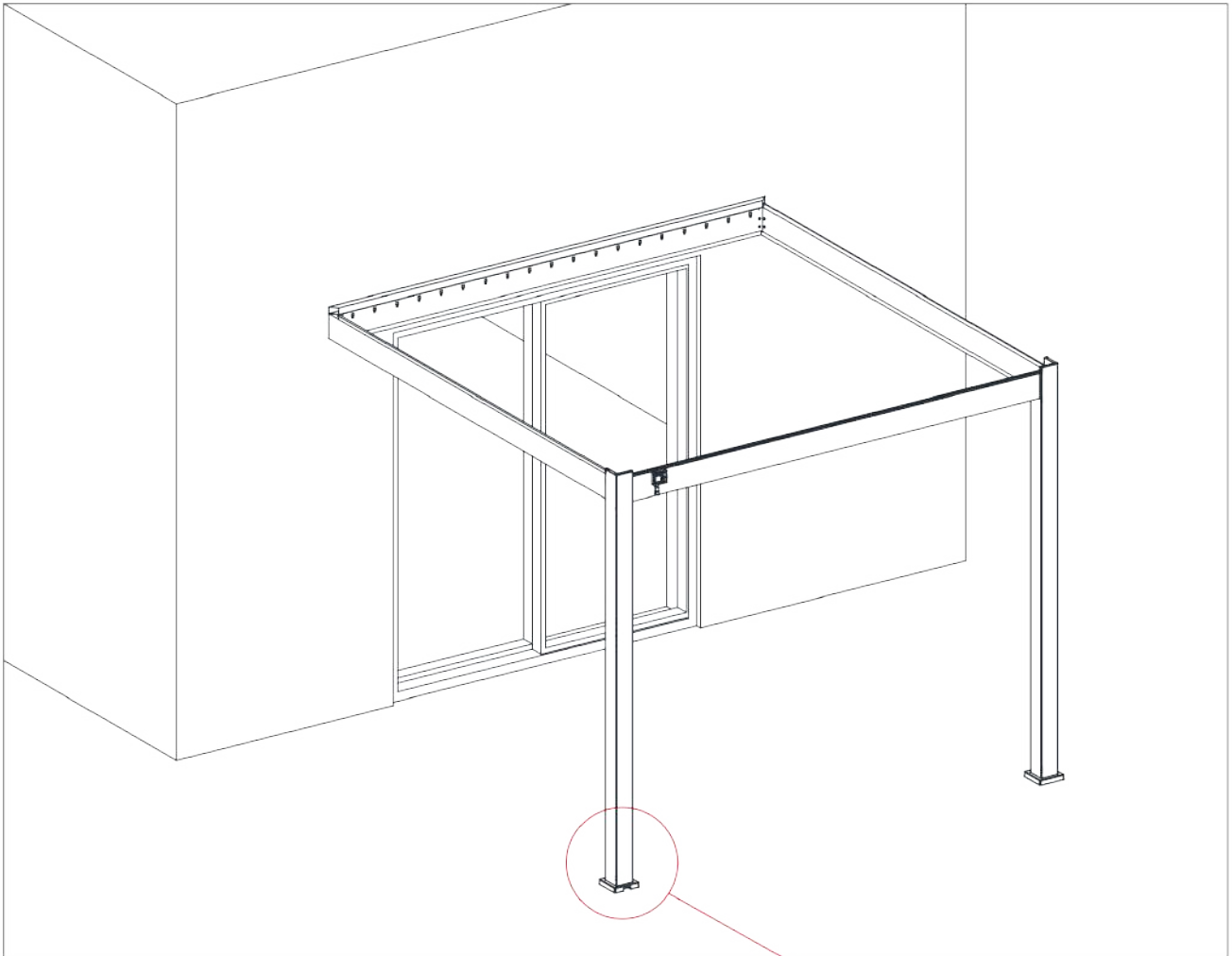

Build the pin composed of the parts **XO**, **MO** and **UO** onto the end caps **LO** and **LO-1**. Make sure the pins are installed in the right direction as shown. Please, note that the direction is different for the parts **LO** and **LO-1**.

Use an electric screwdriver with the hex bit **ZO-2** to insert the bolt **XO** onto the nut **UO** for more convenience. To avoid any injury and to make it easier, we recommend you to secure the nut with the wrench **ZO-5** during this operation.

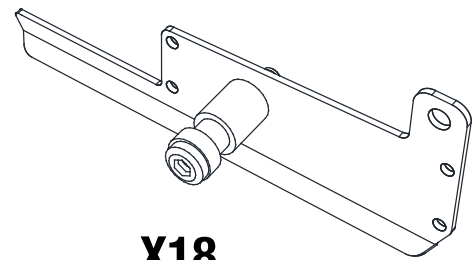
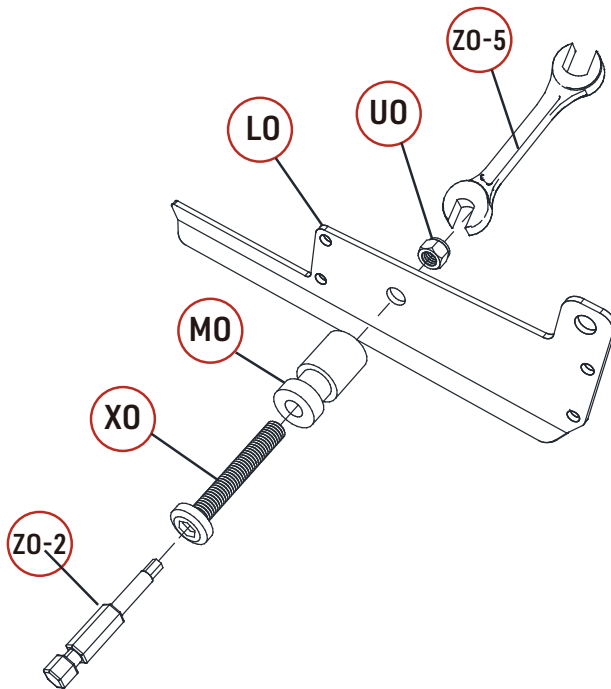
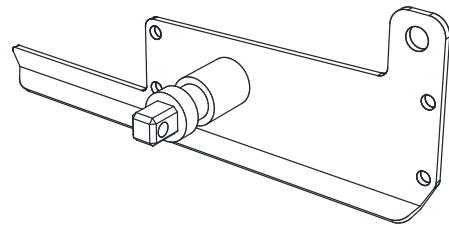

X18

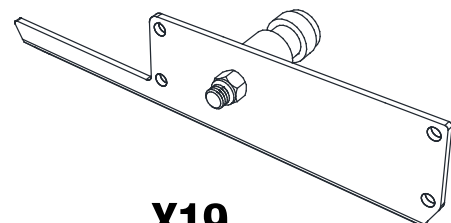
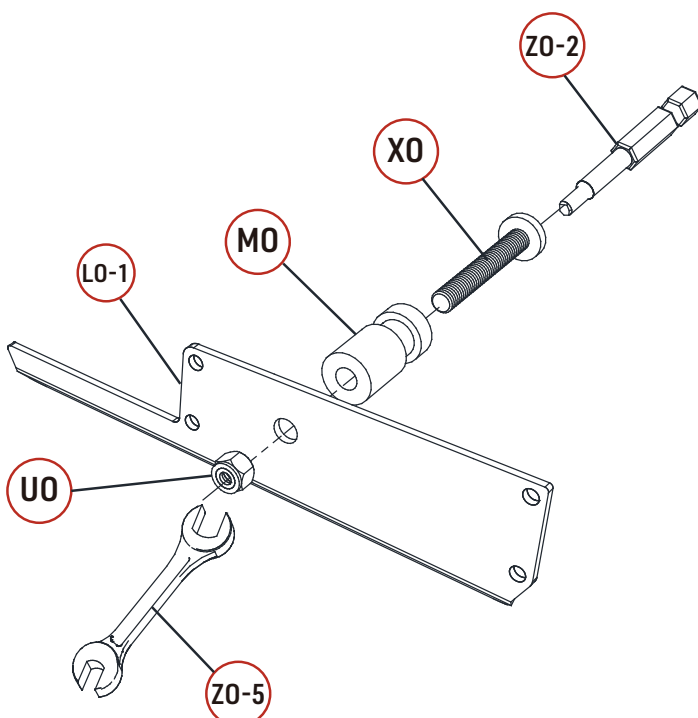

X19

Place the main louver **GO** into the right direction as shown, then fasten the main end cap **KO** onto the right side of the louver and **LO-1** onto the left side, with the screws **WO** using a screwdriver and the T20 **ZO-6**.

X1

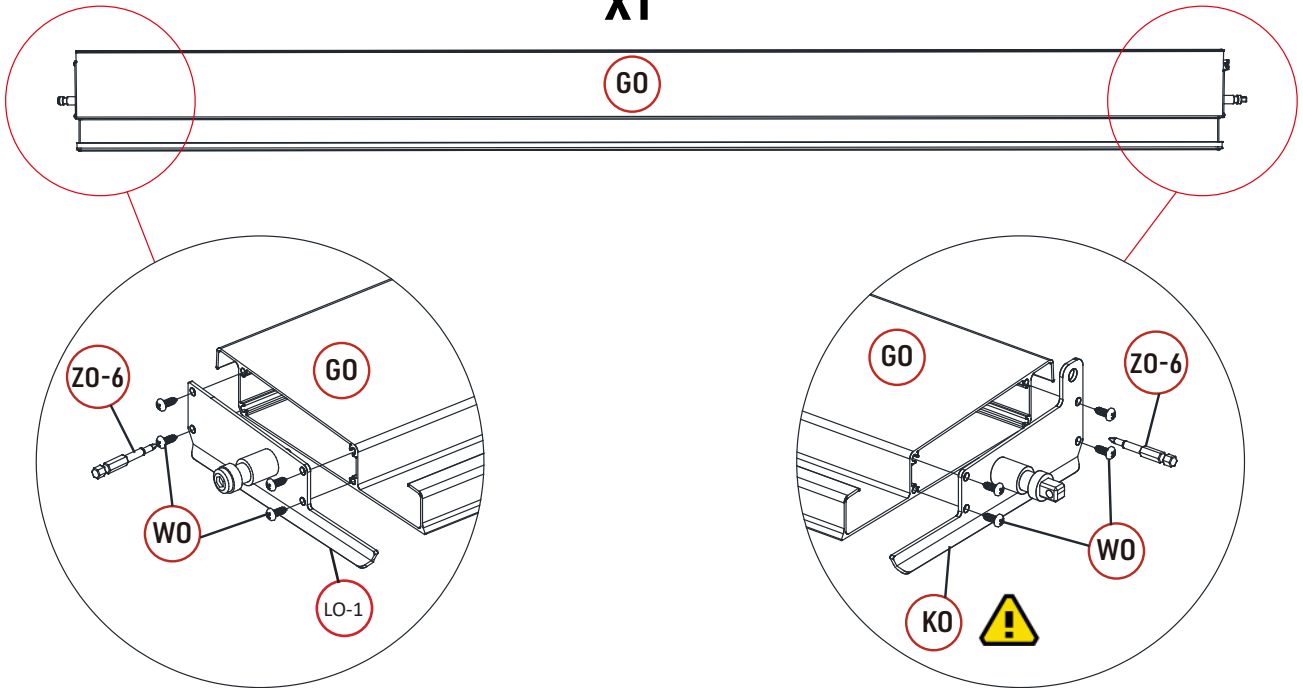

Repeat the same process with all louvers **GO** by fastening the end-caps **LO-1** on the left and the **LO** on the right.

X18

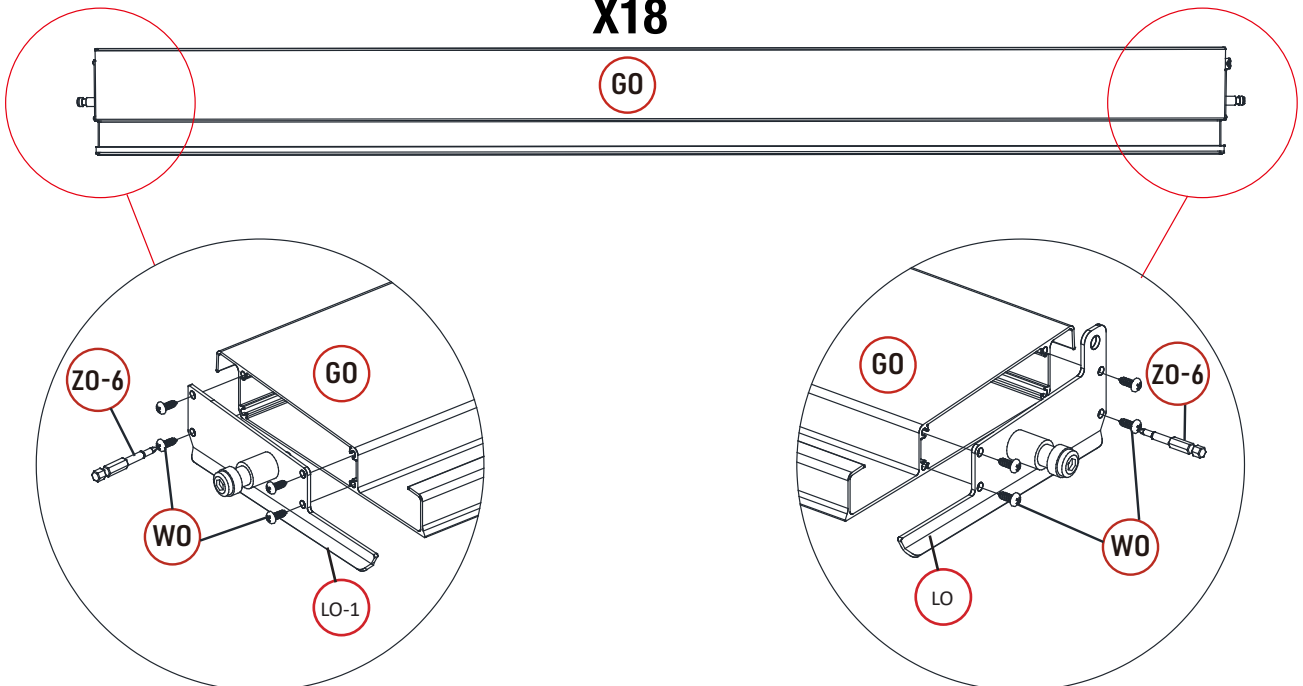

Place and insert the main louver at the 2nd position provided for this purpose, starting from the box side to build the roof.

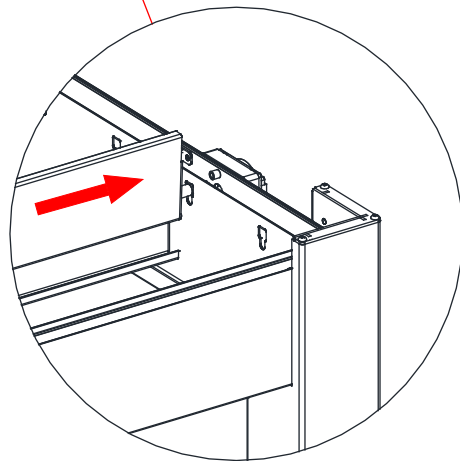
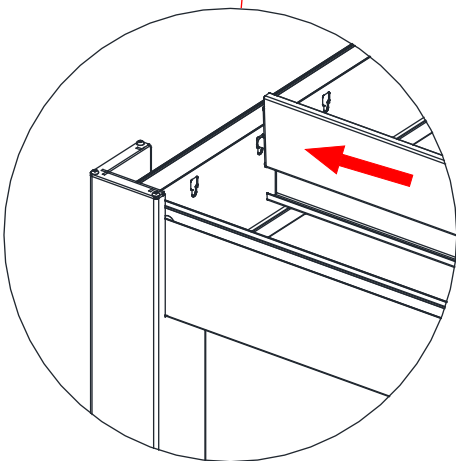
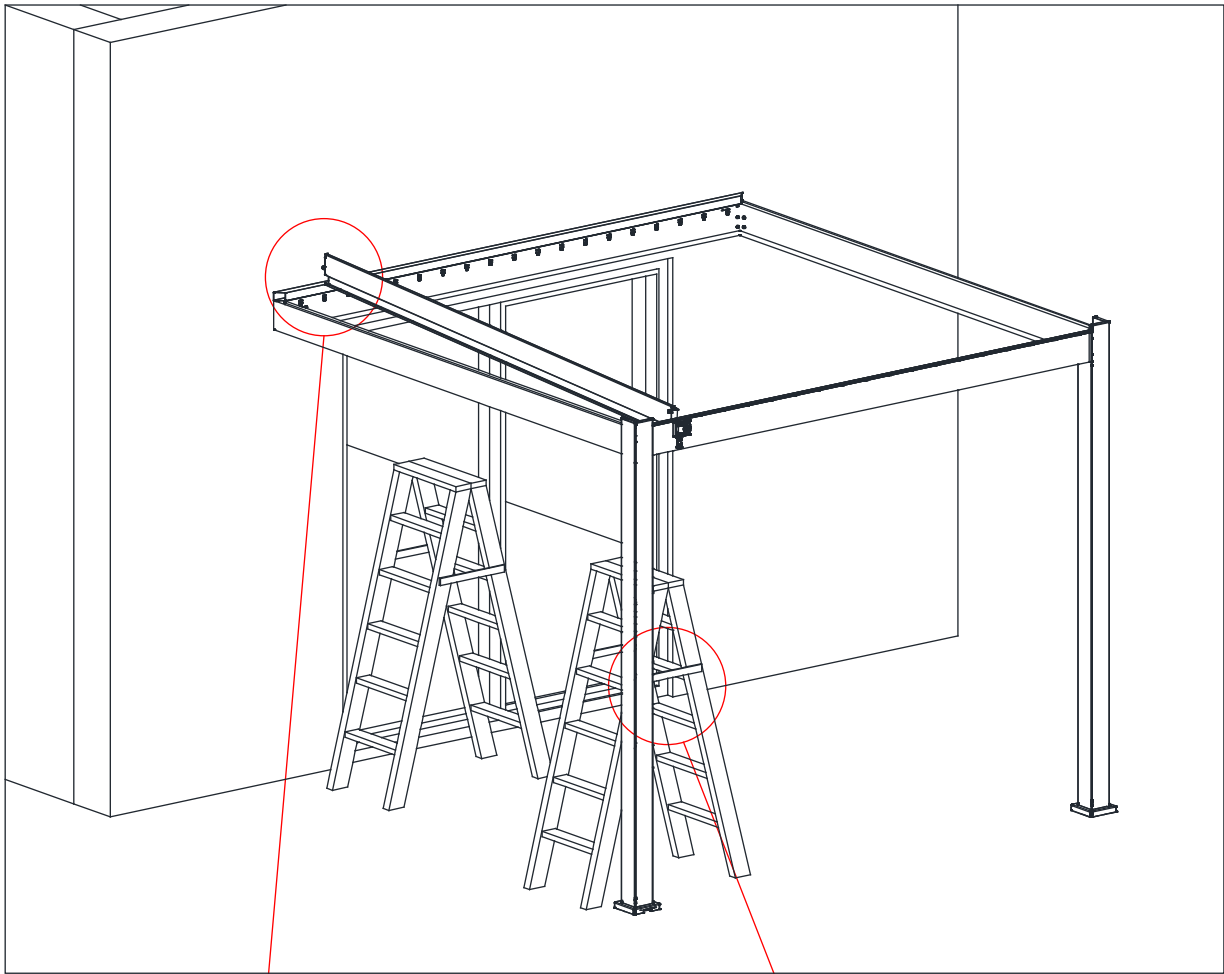

Insert the cylinder **PO** into the gearbox **NO** and through the beam, then push the part until the connection with the pin from the main louver.

Check if the louver rotates correctly from left to right and vice-versa using the hand crank **HO**.

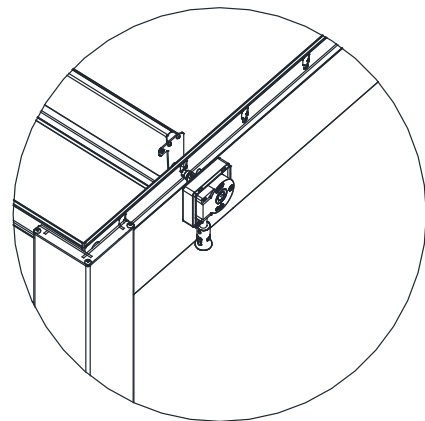
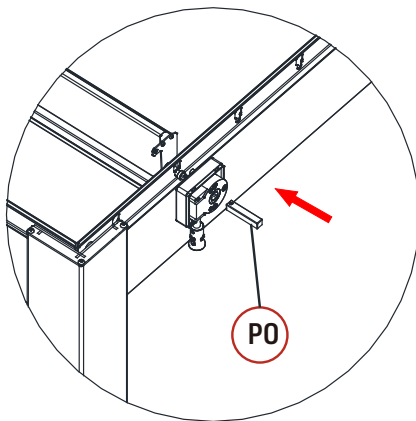
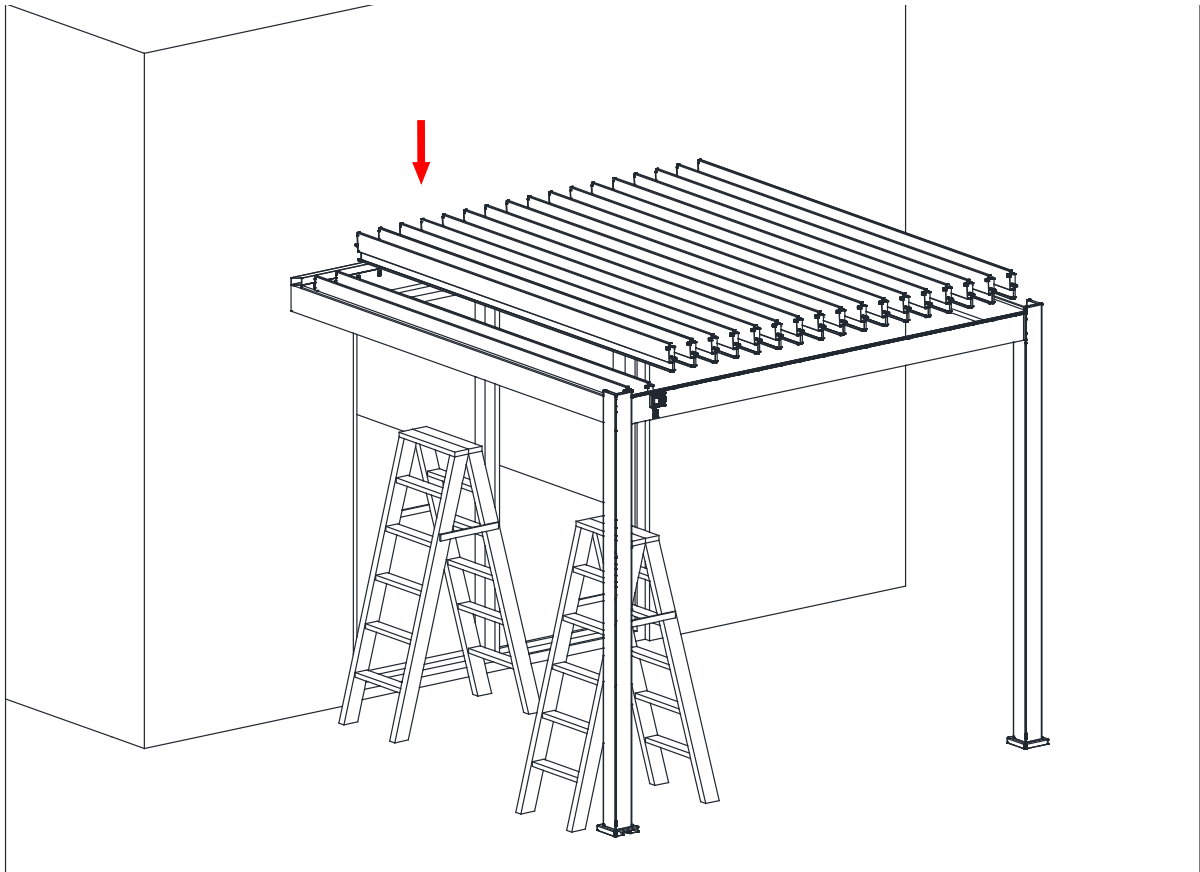

Place the louver in a vertical position, in the right direction as shown to place and insert the remaining louvers one after one.

Fasten the connector bar **FO** onto each louver with the washers **VO** and the nut **UO** as shown, using a screwdriver with the T20 **ZO-6** and the wrench **ZO-5** to secure the nut.

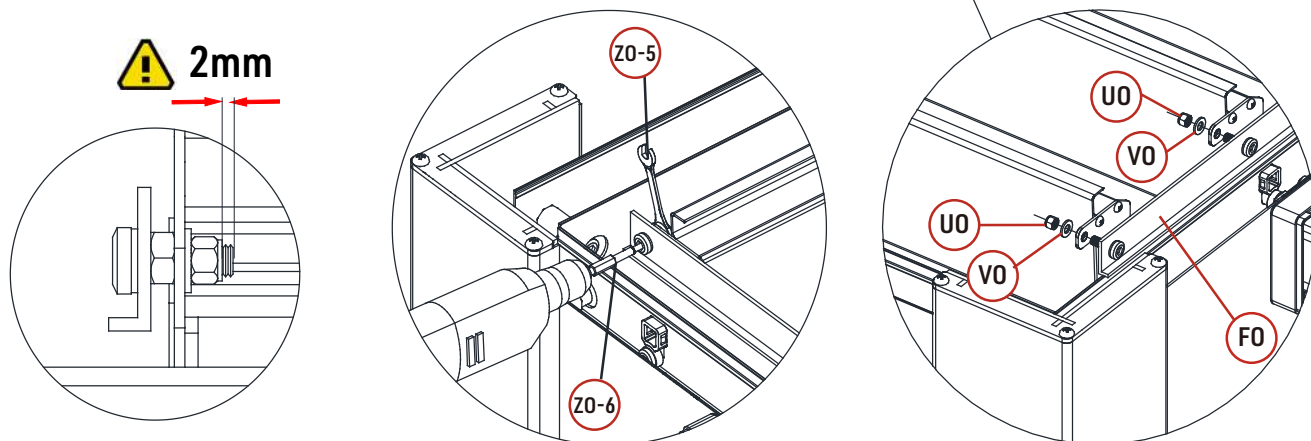
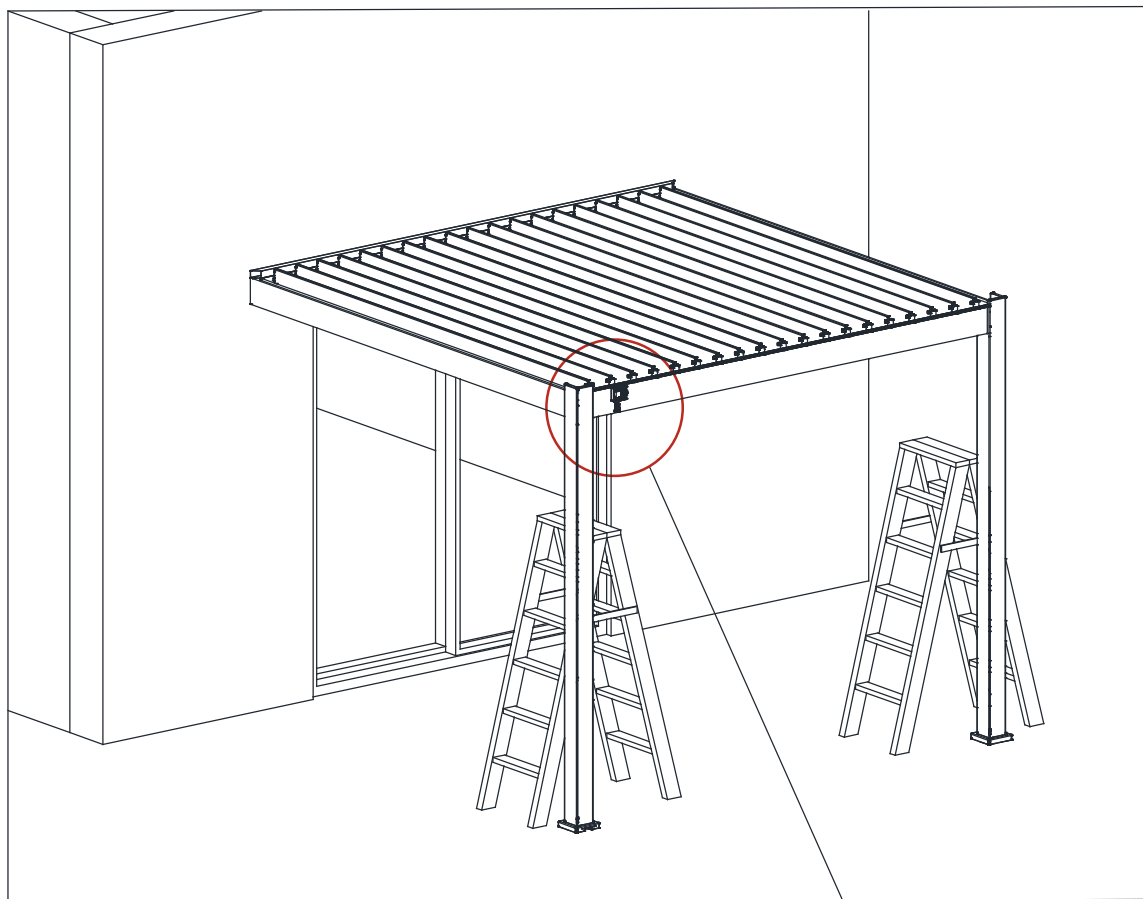

Install and clip on the extension **DO-1**, **DO-3** and **DO-4** onto beams as shown in the drawing. Then, insert the half-moon plastic cap **SO**. The half-moon opening should stay at the bottom of the cap.

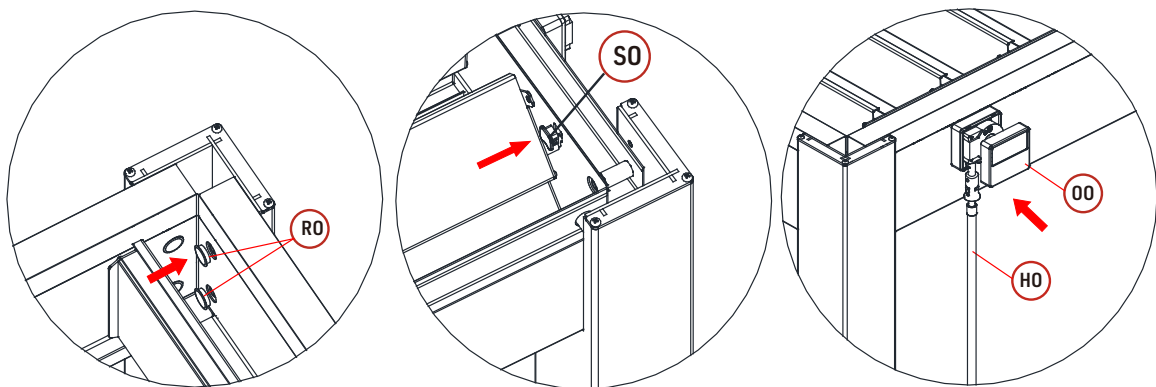
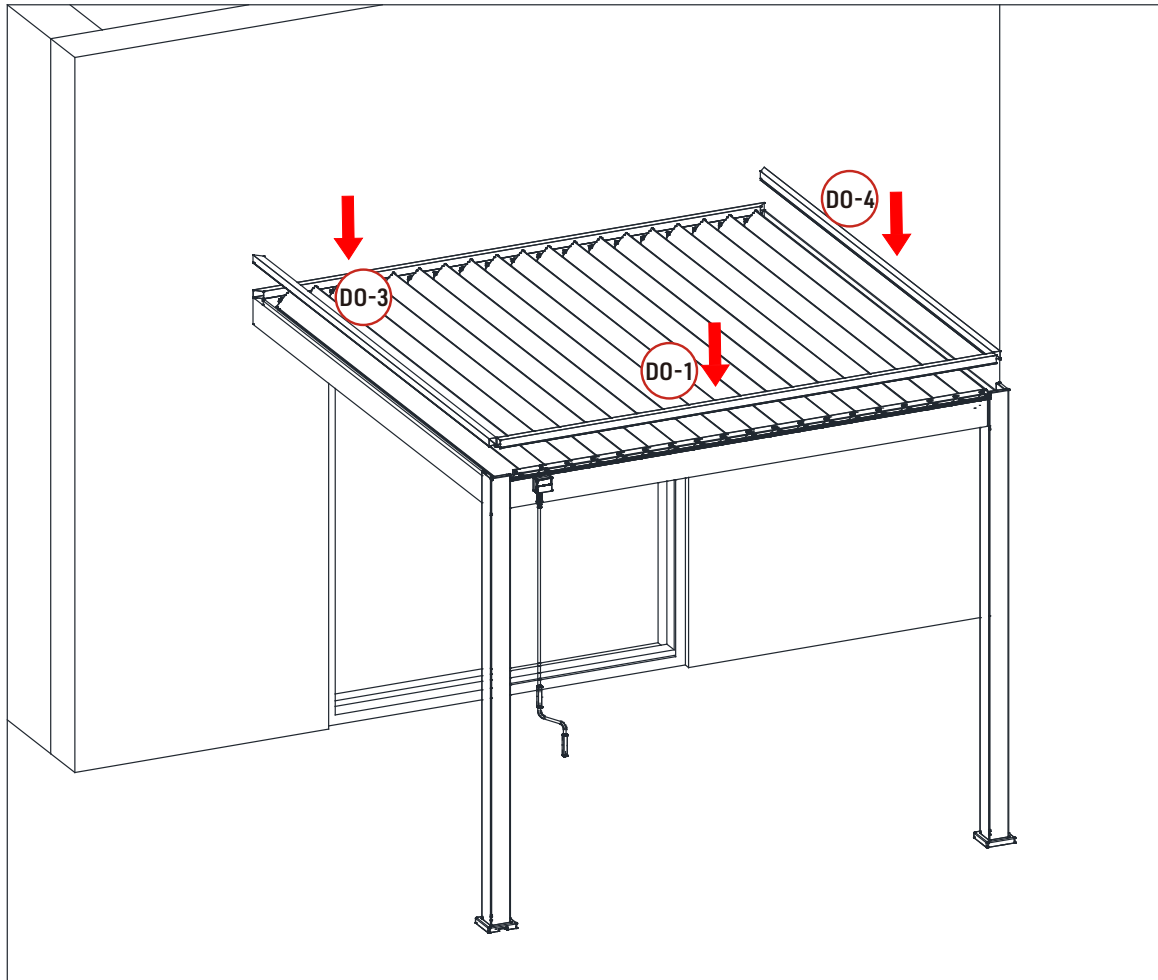

Insert the button cover **RO** on the corner of the frame. Then, clip on the second part of the box **OO** to close the part and finish the assembly.

Pérgola Bioclimática adosada 3x3M

Antracita : 15-728981 / **Blanco** : 15-729087

Le aconsejamos conservar estas instrucciones para consultas futuras.

Le rogamos leer atentamente estas instrucciones antes de empezar el montaje.

El cliente será responsable de cualquier daño o lesión ocasionada por un uso inadecuado del producto.

1. PRECAUCIONES DE SEGURIDAD

Este producto no debe usarse en condiciones climáticas severas: tormenta, viento fuerte, granizo, nieve. Garantizamos la resistencia de la pérgola para soportar vientos hasta 100 km/h y un peso máximo de nieve de 50 kg / m².

En caso de viento o nieve violento, se recomienda dejar las lamas en posición abierta. Si se olvida, habrá que quitar la nieve de la pérgola para evitar una sobrecarga significativa en las lamas.

Nuestra pérgola puede soportar lluvias fuertes, no obstante, no podemos asegurar una impermeabilidad al 100%.

En caso de fenómenos meteorológicos excepcionales, su estanqueidad puede verse comprometida. No guarde enseres que temen la humedad debajo de la pérgola. No se sube al tejado ni a la estructura de la pérgola.

2. MONTAJE

Dependiendo de la ubicación y la superficie, las construcciones pueden estar sujetas a una solicitud de permiso de obra. Ponerse en contacto con las autoridades locales para determinar si la instalación está autorizada.

Montaje del producto :

- Se necesitan de 2 a 3 personas
- Retire las láminas protectoras (tiempo estimado: 1 hora)
- Mantenga a los niños lejos de la zona de montaje.
- Tenga cuidado con el riesgo de pellizcos. Llevar siempre guantes de protección
- Nunca apriete completamente los tornillos antes de haber ensamblado la pieza en cuestión
- Es importante seguir estas instrucciones paso a paso.
- Compruebe los niveles, las diagonales y la plomada
- Fije la pérgola sólo después del montaje

No se pueden realizar modificaciones en el producto. Los productos modificados por el cliente no están cubiertos por la garantía del fabricante.

La ubicación debe elegirse de forma adecuada. Se recomienda evitar montar su pérgola de cara a los vientos dominantes y debajo de un árbol.

La pérgola debe montarse sobre una superficie estable y nivelada, se recomienda instalarla sobre una losa de hormigón 25x25 cm o soportes de hormigón al nivel de cada poste. Le pedimos que ancle correctamente la pérgola al suelo utilizando las piezas TO.

Si desea colocar su pérgola cerca de su casa o edificio, le pedimos que verifique la presencia de canales de desagüe.

La pérgola Ombréa® no podrá resistir y garantizar una estanqueidad perfecta si el agua de lluvia de su hogar fluye hacia ella.

En caso de incumplimiento de las recomendaciones de montaje, no se podrá aplicar la garantía.

3. MANTENIMIENTO

Es necesario un mantenimiento regular para asegurar la longevidad y conservar el aspecto estética inicial del producto. Recomendamos:

- Lave su pérgola una o dos veces al año con agua, una esponja o un trapo suave. No usar productos agresivos ni soportes abrasivos.
- Compruebe la presión de los tornillos con regularidad (al menos una vez al año).
- Engrase las piezas de tornillerías con regularidad (al menos una vez al año).
- Asegúrese de que nada interfiera con el flujo de agua en las canales de desagüe (hojas, ramas...).
- Elimine el agua que pueda estancarse alrededor de los pies de la pérgola (llevando la falda de poste).

4. GARANTÍA

Ombréa® garantiza la disponibilidad de las piezas de repuestos durante 2 ó 5 años (según el producto). La garantía solo se aplicará si el almacenamiento, montaje, uso de forma normal y mantenimiento regular se respetan.

Exclusión de la garantía :

- El desgaste normal inherente a los productos.
- Pérdida o rotura de cualquier pieza durante el desembalaje o la instalación.
- Falta de mantenimiento, negligencia, vandalismo, impactos con objetos extraños, uso de fuerza, contacto con abrasivos, estética, desmantelamiento, reconstrucción o reubicación.
- Fuerzas mayores: granizo, vientos fuertes, tormentas, nieve, inundaciones, rayos ...
- Producto modificado por el usuario.

La garantía se limita a la sustitución de piezas de repuestos o del producto suministrado, excluyendo todo gastos y compensaciones de cualquier tipo.

Todas las reclamaciones de garantía deben realizarse en el punto de venta (tienda o sitio web) donde se adquirió el producto.

5. LISTA DE PIEZAS (POR BULTOS)



Antes de proceder al montaje de su pérgola bioclimática, revise que todas las piezas están incluidas y no dañadas.

Cualquier pieza faltante debe informarse dentro de los 10 días posteriores a la compra. Puede reclamar a través de su distribuidor o enviar una solicitud directamente en nuestra página web sav.comintes.com.

No tire el embalaje sin asegurarse de que la pérgola está funcionando correctamente.

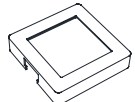

BULTO 1/4 (POSTES Y HERRAJES)

| Referencias | Diagrama | Cantidad |
|-------------|---|----------|
| AO |  POSTE | 2 |





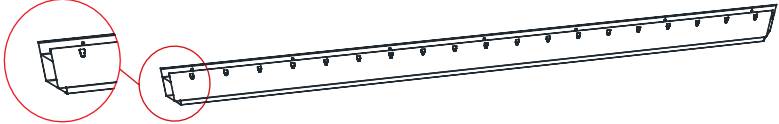
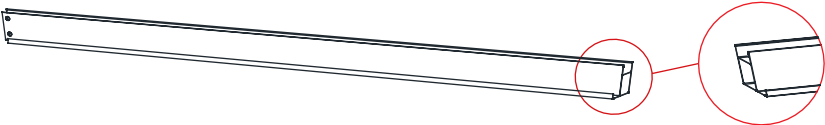

| Referencias | Diagrama | Cantidad |
|-------------|--|----------|
| IO |  FALDA DE POSTE | 2 |
| JO |  PLETINA DE SUJECIÓN | 2 |













| Referencias | Diagrama | Cantidad |
|-------------|--|----------|
| TO |  M8x80 TACO DE HORMIGÓN | 8 |
| XO-1 |  6x35 PERNO 6X35 | 8 |



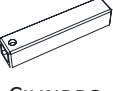

BULTO 2/4 (VIGAS Y HERRAJES)



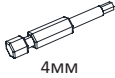

| Referencias | Diagrama | Cantidad |
|-------------|--|----------|
| BO-1 |  VIGA PRINCIPAL | 1 |
| BO-2 |  VIGA TRASERA | 1 |
| CO-1 |  VIGA LATERAL (IZQUIERDA) | 1 |
| CO-2 |  VIGA LATERAL (DERECHA) | 1 |

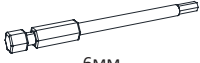
BULTO 2/4 (VIGAS Y HERRAJES)

| Referencias | Diagrama | Cantidad |
|-------------|---|----------|
| DO-1 |  PROLONGACIÓN VIGA (DELANTERA) | 1 |
| DO-2 |  PROLONGACIÓN VIGA (TRASERA) | 1 |
| DO-3 |  PROLONGACIÓN VIGA (IZQUIERDA) | 1 |
| DO-4 |  PROLONGACIÓN VIGA (DERECHA) | 1 |
| FO |  BARRA DE CONEXIÓN (TORNILLOS INCLUIDOS) | 1 |
| HO |  MANIVELA | 1 |

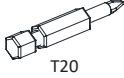
| Referencias | Diagrama | Cantidad | Referencias | Diagrama | Cantidad |
|-------------|--|----------|-------------|---|----------|
| LO-2 |  ESQUINA DE PLÁSTICO | 2 | UO |  TUERCA | 56 |
| NO |  CAJA DE ENGRANAJES | 1 | VO |  ARANDELA | 19 |
| OO |  CAJA | 1 | XO |  PERNO 6x40 | 37 |
| PO |  CILINDRO | 1 | XO-2 |  TORNILLO AUTOPERFORANTE 5x19 | 8 |
| QO |  TORNILLO DE FIJACIÓN DE LA VIGA | 8 | YO |  PERNO 6x45 | 3 |
| RO |  TAPA DE ACABAMIENTO | 8 | ZO-1 |  LLAVE ALLEN 4MM | 1 |
| SO |  CUÑA DE MEDIA LUNA | 38 | | | |



| Referencias | Diagrama | Cantidad |
|-------------|--|----------|
| ZO-2 |  4MM PUNTA DESTORNILLADOR 4MM | 1 |
| ZO-3 |  6MM LLAVE ALLEN 6MM | 1 |
| ZO-4 |  6MM PUNTA DESTORNILLADOR 6MM | 1 |
| ZO-5 |  10MM LLAVE PLANA 10MM | 1 |

| Referencias | Diagrama | Cantidad |
|-------------|--|----------|
| ZO-6 |  T20 PUNTA DESTORNILLADOR T20 | 1 |
| ZO-7 |  PUNTA | 1 |
| ZO-8 |  COLA | 1 |
| TO-1 |  TACO 8X100 | 1 |

BULTO 3/4 (LAMAS Y HERRAJES)

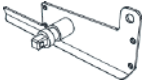
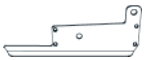
| Referencias | Diagrama | Cantidad |
|-------------|---|----------|
| GO |  LAMA | 9 |

| Referencias | Diagrama | Cantidad |
|-------------|--|----------|
| KO |  TAPA DE LA LAMA PRINCIPAL | 1 |
| LO |  TAPA DE LA LAMA A | 18 |

| Referencias | Diagrama | Cantidad |
|-------------|--|----------|
| LO-1 |  TAPA DE LA LAMA B | 19 |
| MO |  PASADOR | 37 |

| Referencias | Diagrama | Cantidad |
|-------------|---|----------|
| WO |  4X16 TORNILLOS 4X16 | 152 |

BULTO 4/4 (LAMAS)

| Referencias | Diagrama | Cantidad |
|-------------|--|----------|
| GO |  LAMA | 10 |

Las piezas de aluminio son las siguientes: AO, BO-1, BO-2, CO-1, CO-2, DO-1, DO-2 DO-3, DO-4, FO, GO, IO, KO, LO et LO1.

Los tornillos y demás piezas son de acero inoxidable, acero galvanizado, plástico o nailon.

Para más información, consulte las especificaciones técnicas del producto y nuestra página de preguntas frecuentes en www.pergola-ombrea.es o póngase en contacto con su distribuidor.

6. EQUIPO (NO SUMINISTRADO) NECESARIO PARA EL MONTAJE



Gafas y guantes de protección



2 escaleras de tijera



Taladro + broca para hormigón de 12 mm



Destornillador eléctrico

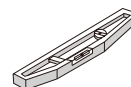

Nivel de burbuja



Cúter



Casco de seguridad

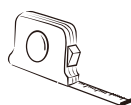

Cinta métrica

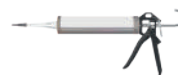

Colla

7. CONTACTO

Siempre estamos buscando formas de mejorar, así que no dudes en enviarnos tus comentarios y sugerencias a la siguiente dirección: info@pergola-ombrea.es

Estaremos encantados de recibir las bonitas fotos de tu instalación.

El equipo de Ombréa te agradece tu compra y te desea días de felicidad aprovechándote tu pérgola !

8. PLAN DEL MONTAJE (dimensiones en mm)

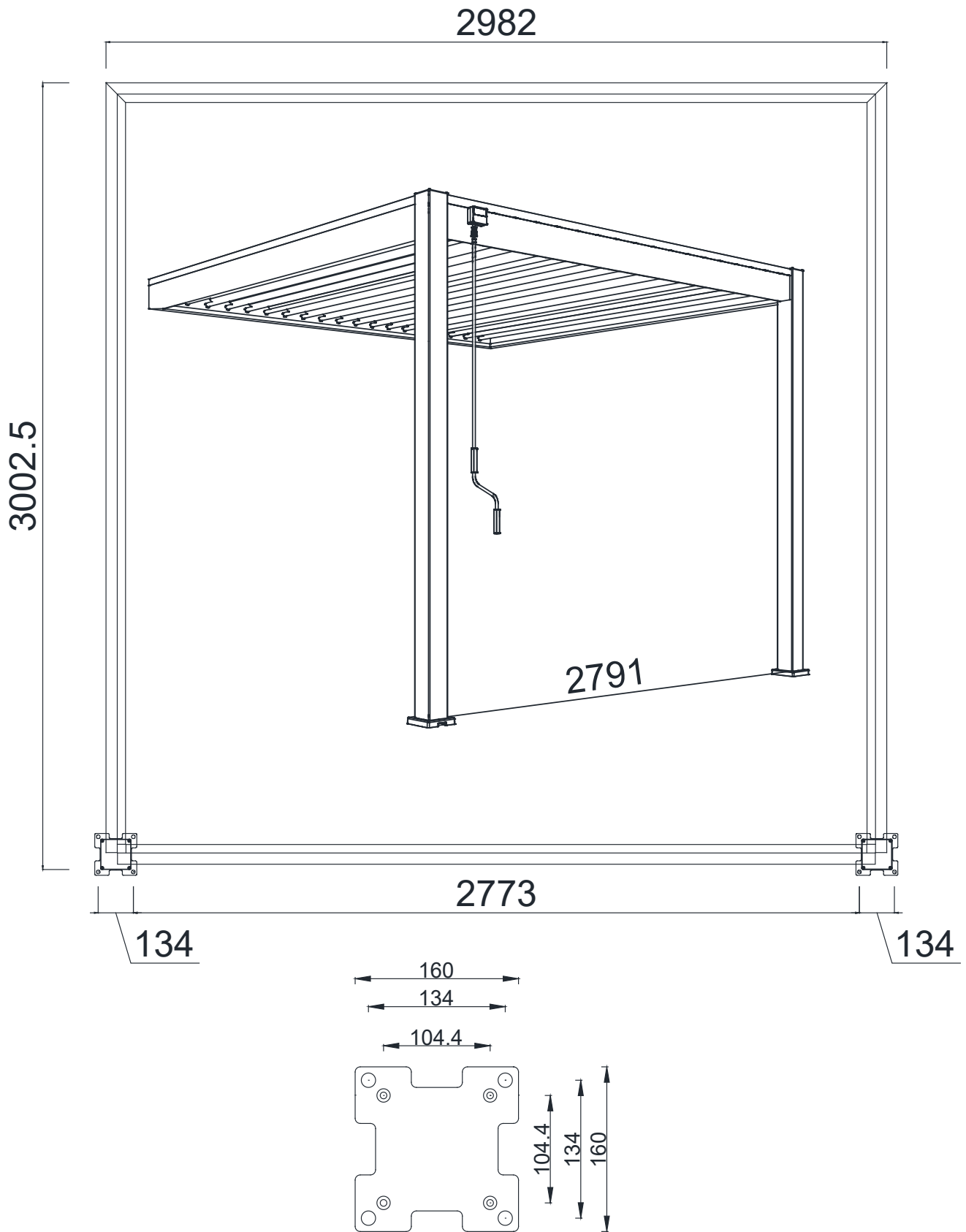

9. ÉTAPES DE MONTAGE

Para evitar daños en tu pérgola durante el proceso de montaje, te recomendamos que coloques las piezas sobre una mesa, caballetes y preparar una superficie plana y limpia.

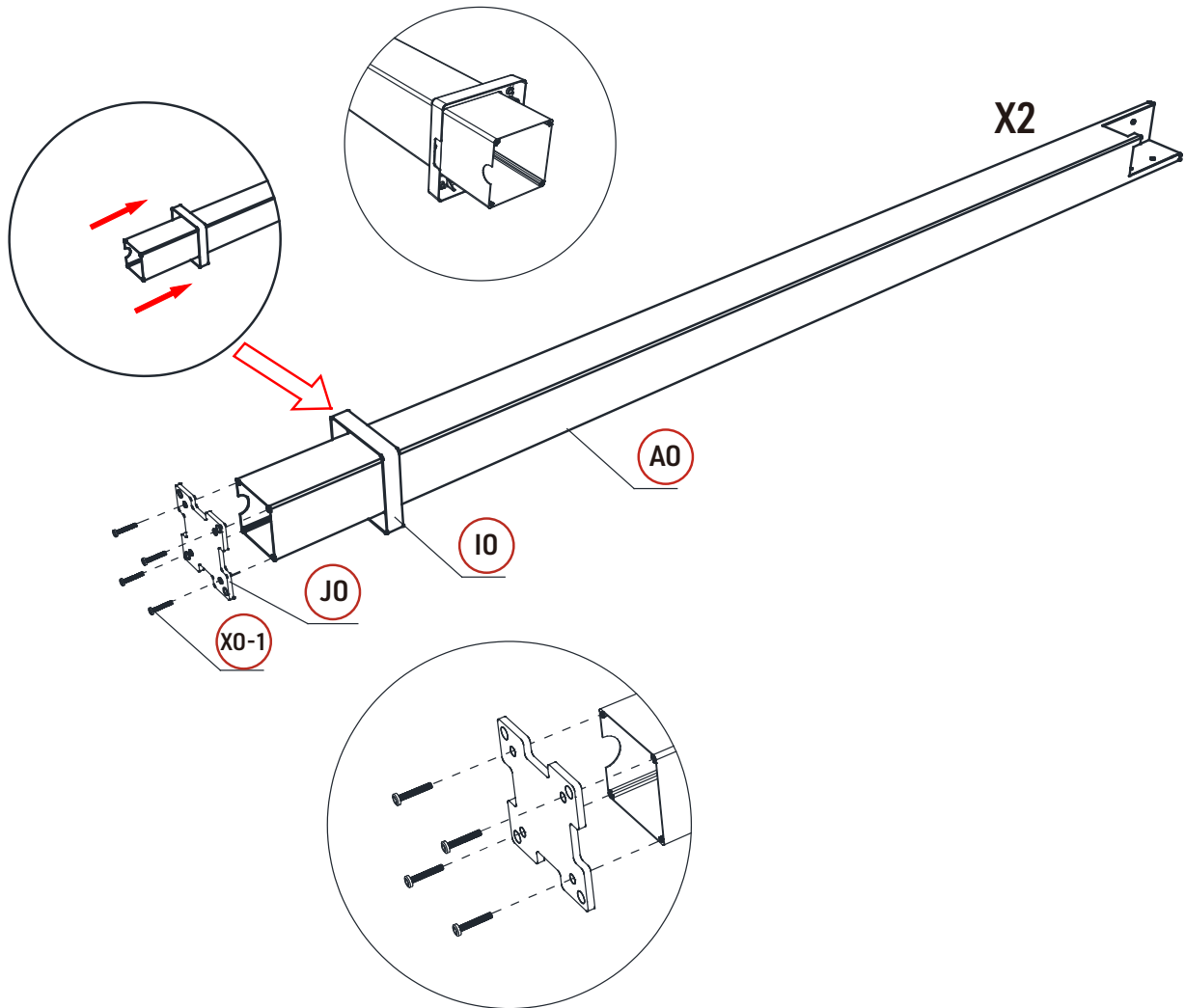

Desliza las faldas **IO** sobre los postes **AO**, colocando la abertura en la misma dirección que la abertura del poste en forma de media luna en su parte inferior.

A continuación, fija la pletina **JO** con los tornillos **XO-1** utilizando un destornillador. Aprieta ligeramente al principio, y luego a fondo una vez que todos los tornillos estén colocados.

Separa las extensiones **DO-1**, **DO-2**, **DO-3** y **DO-4** de las vigas **BO-1**, **BO-2**, **CO-1** y **CO-2**. Guarda las piezas retiradas para más tarde.

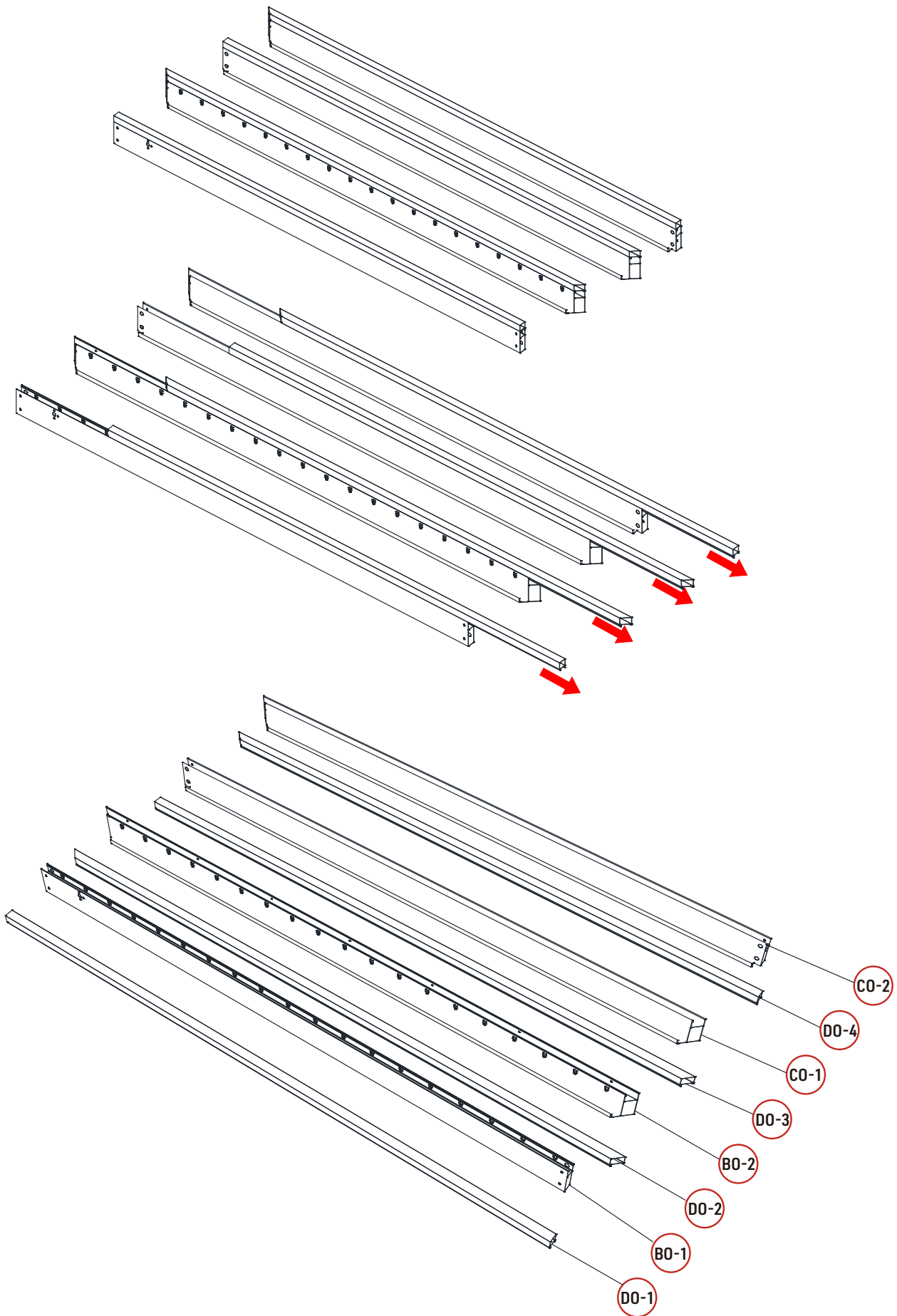

Inserta las esquinas **LO-2** en la viga **BO-2**, luego atornilla como se muestra en el diagrama con los tornillos autoperforantes **XO-2**, utilizando un destornillador y la punta **ZO-7**.

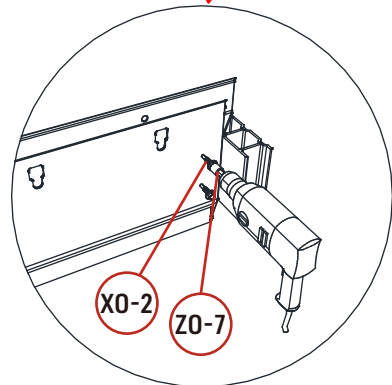
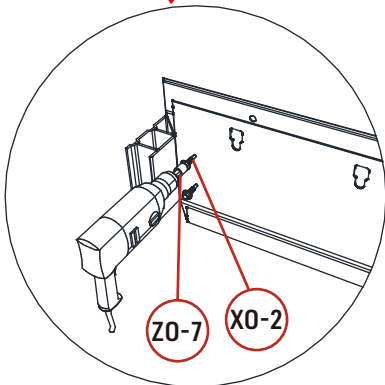
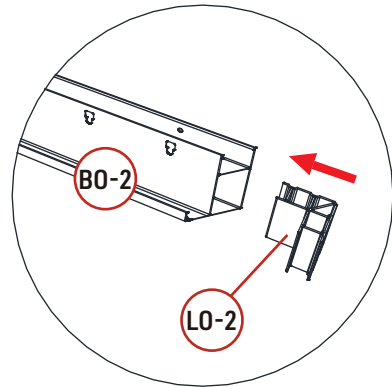
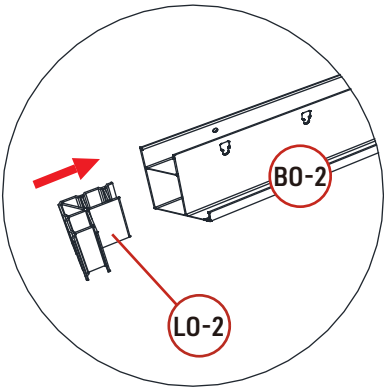

En una pared plana, coloca la viga **BO-2** sobre la fachada a 237 cm de altura.

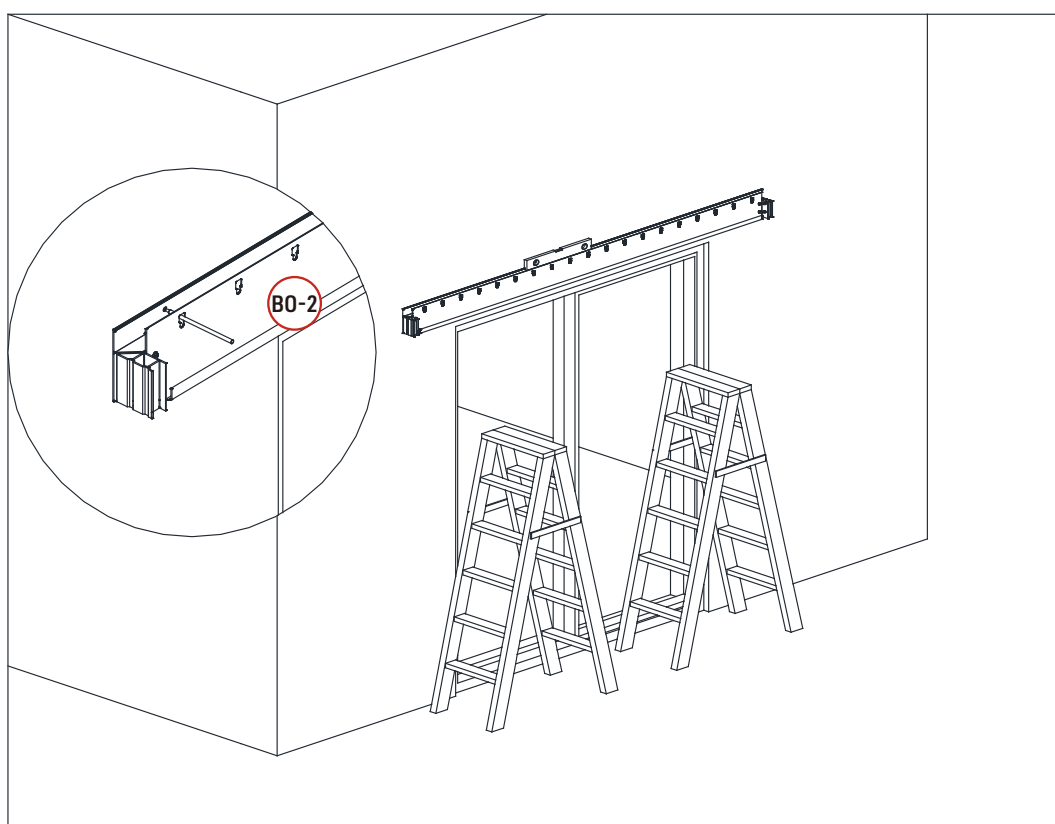

Con la ayuda de 2/3 personas, utiliza un nivel de burbuja para asegurarte de que la viga **BO-2** esté recta y marca con un lápiz los orificios de perforación, antes de retirar la viga.

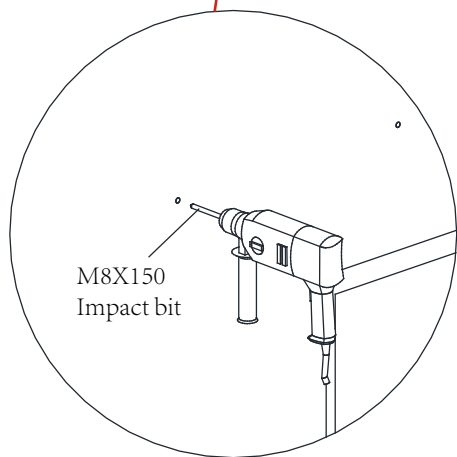
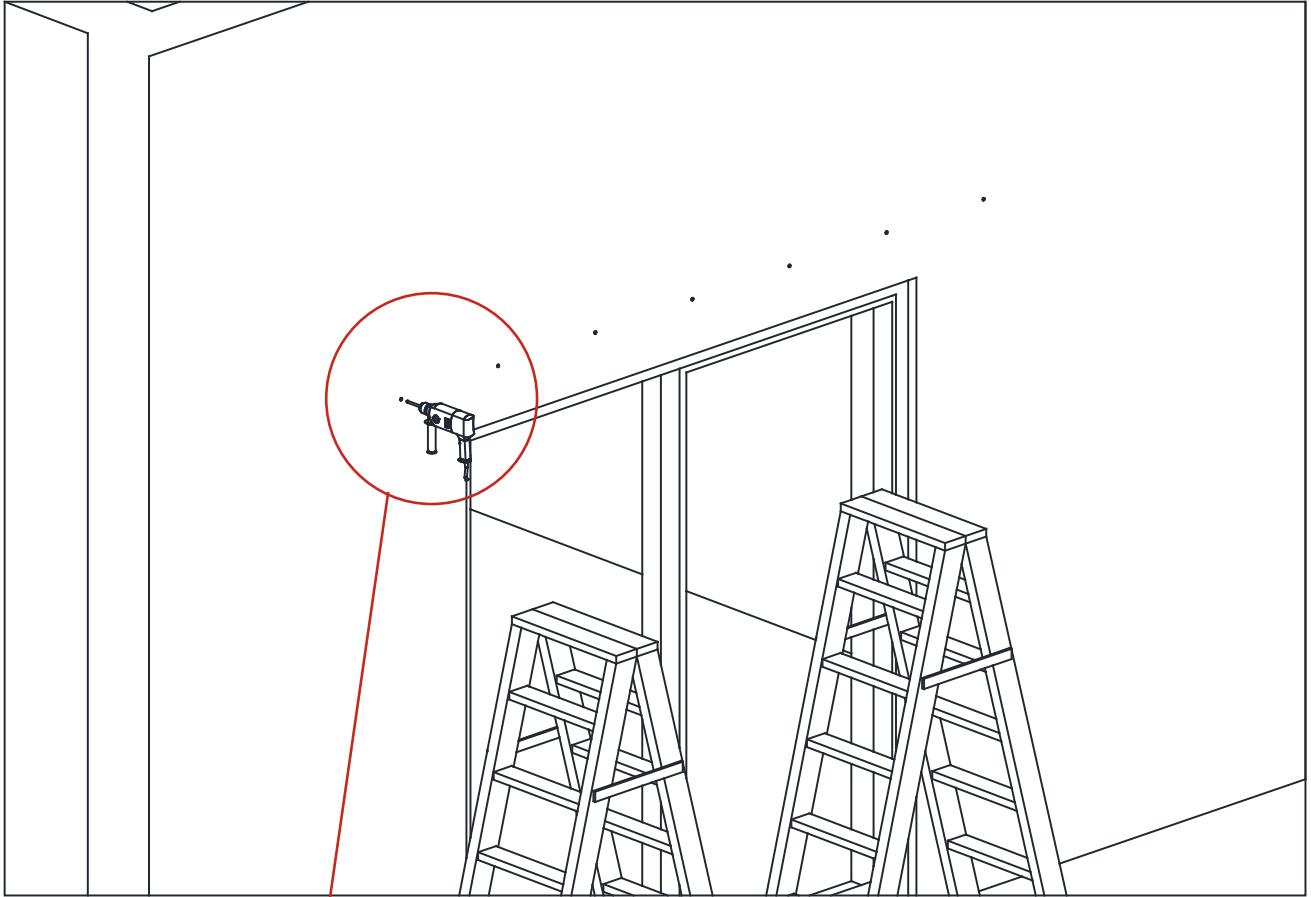

Taladra los agujeros marcados en la pared con un taladro y una broca M8x150.

Consejo: para obtener la máxima estanqueidad, se recomienda aplicar una cola entre la pared y la viga mural.

Coloca de nuevo la viga de pared **BO-2** y manténla nivelada para que quede recta. A continuación, inserte los tacos **TO-1** como se muestra en el diagrama.

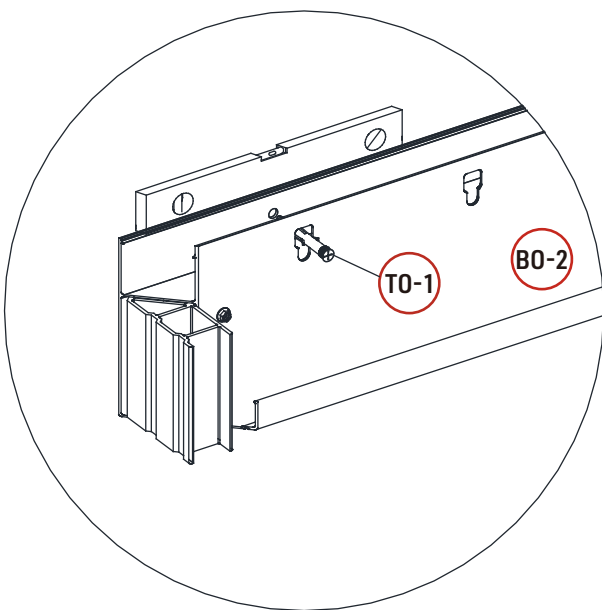
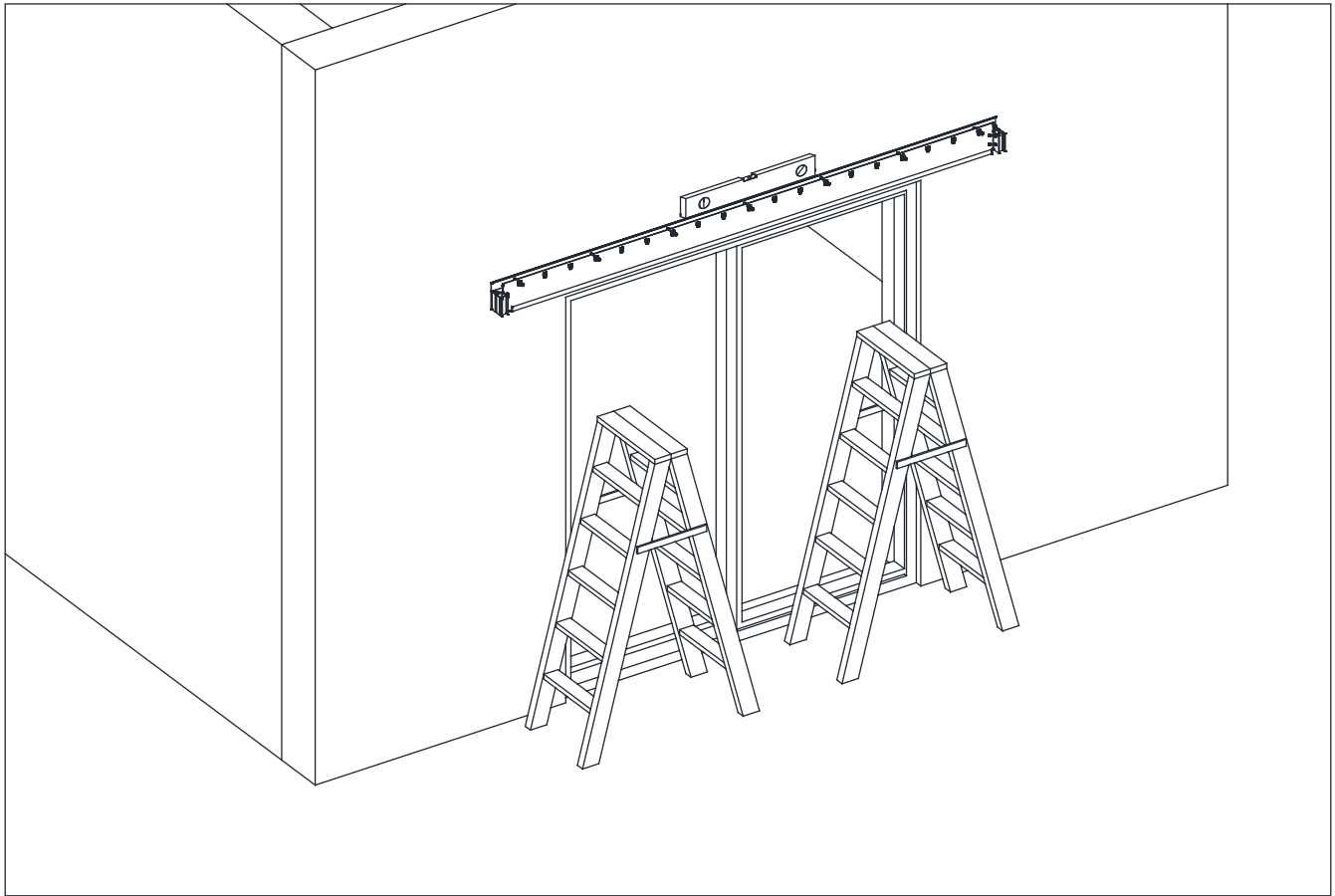

Empuja la prolongación de la viga **DO-2** sobre la viga de pared **BO-2**.

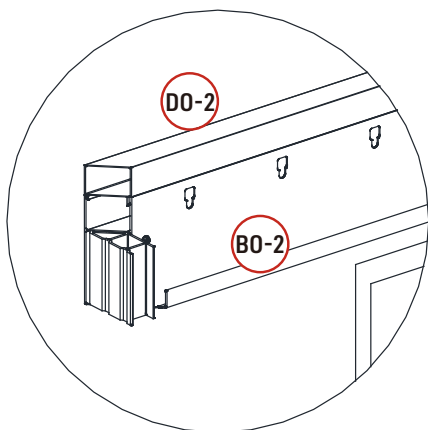
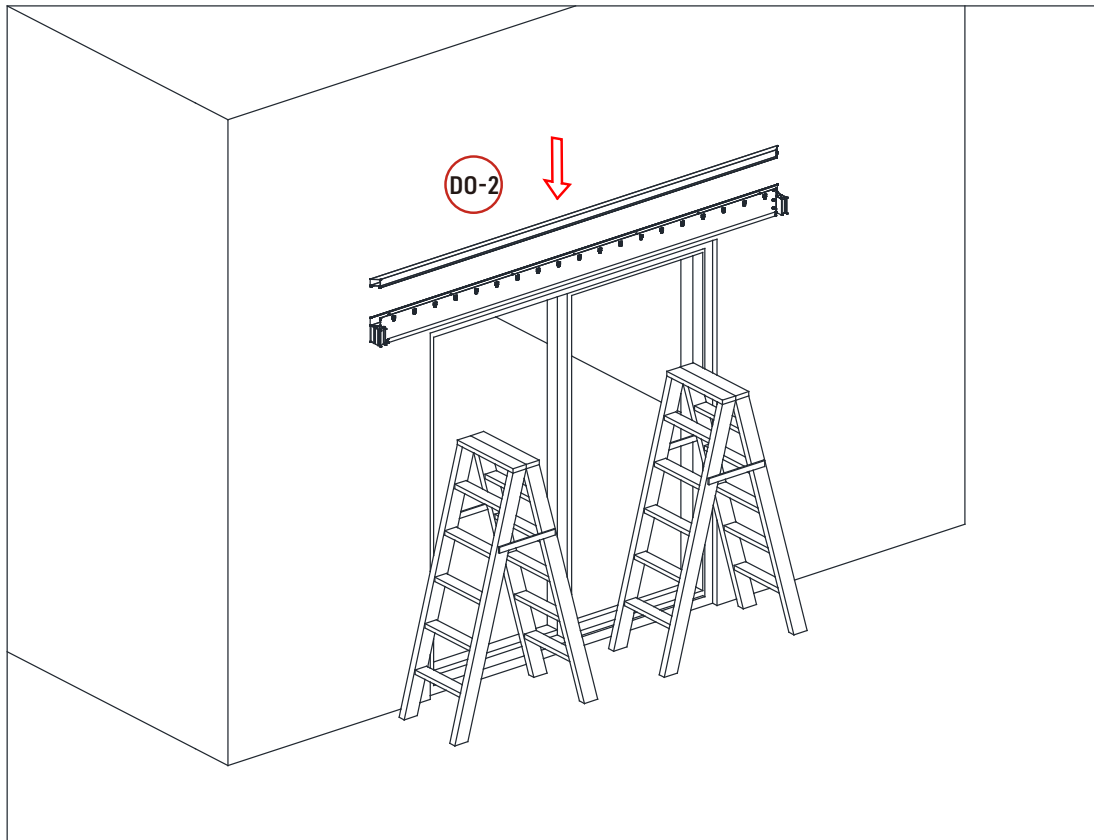

Fija las vigas **CO-1** y **CO-2** a los postes **AO** con los tornillos **QO** como se indica en el esquema, utilizando un destornillador y la punta **ZO-4** o la llave Allen **ZO-3**.
Luego conecta el conjunto e a la viga de pared **BO-2** encajando en ella la pieza **LO-2**.

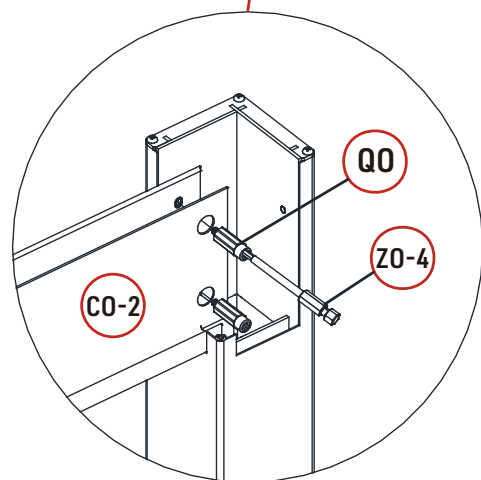
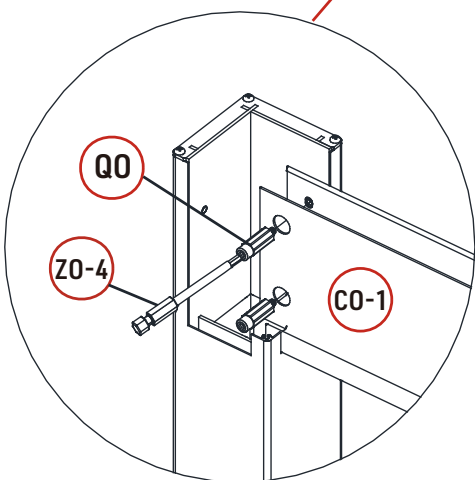
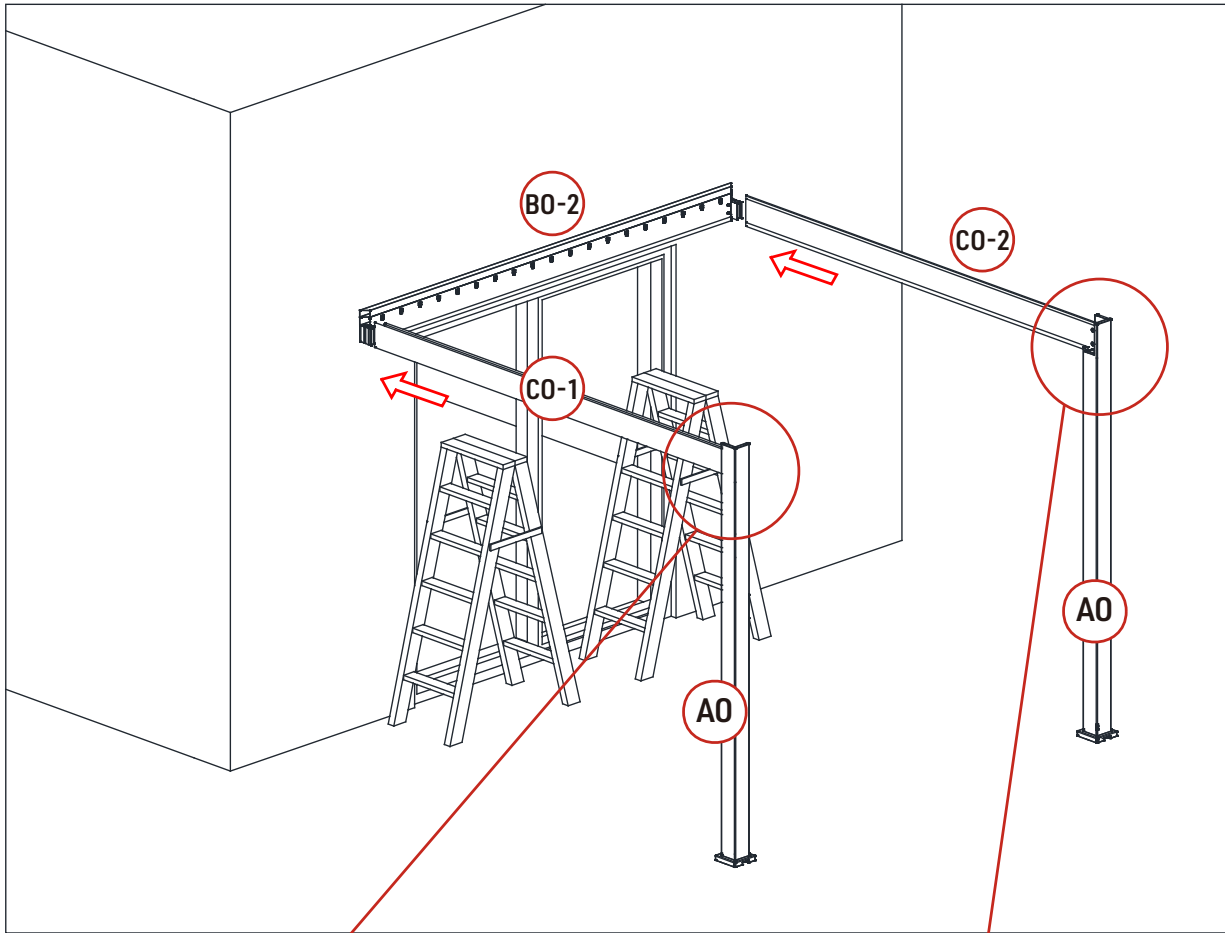

Fija las vigas laterales **CO-1** y **CO-2** a la esquina **LO-2** con los tornillos autoperforantes **XO-2** como se muestra en el diagrama, utilizando un destornillador y la punta **ZO-7**.

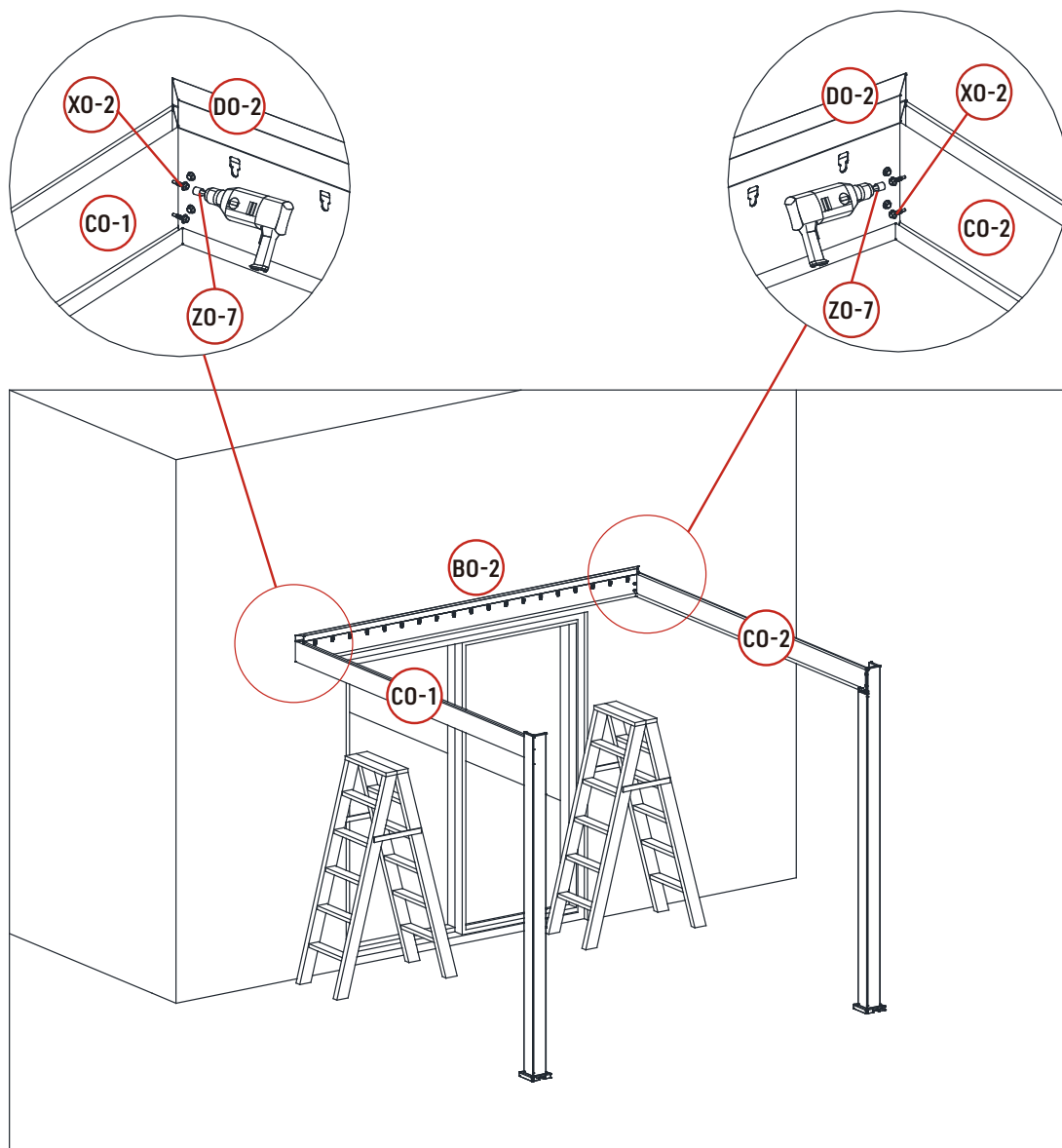

Aplica la cola **ZO-8** en las esquinas de ambos lados del marco para conseguir la máxima estanqueidad, como se muestra en el diagrama.

A continuación, para cerrar el marco, fija la viga delantera **BO-1** a los postes **AO** con los tornillos **QO**, utilizando un destornillador y la punta **ZO-4** o la llave Allen **ZO-3**.

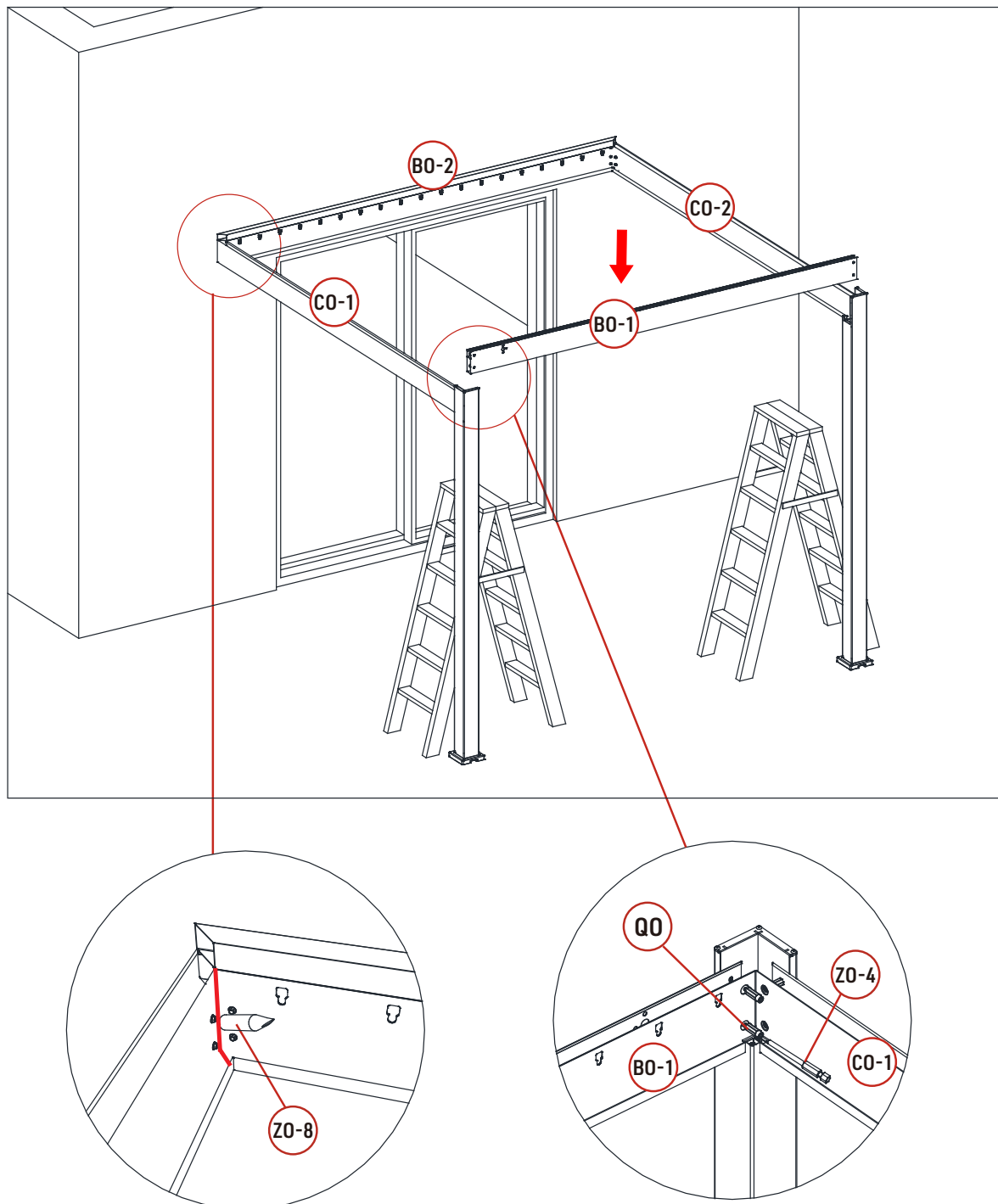

Empareja y atornilla la primera parte de la caja **OO** con el engranaje **NO** a la viga principal **BO-1**, con los 3 tornillos **YO**, utilizando la llave Allen **ZO-3** o un destornillador y la punta **ZO-4**.

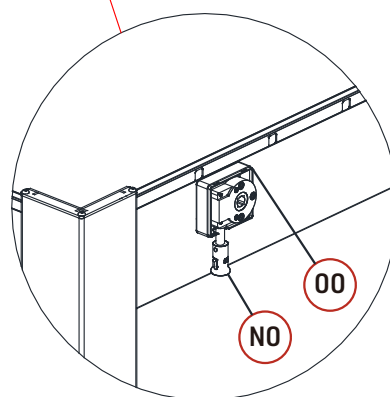
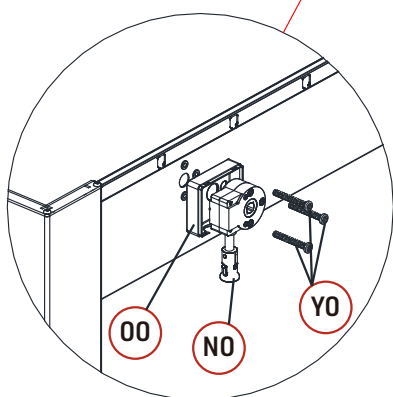
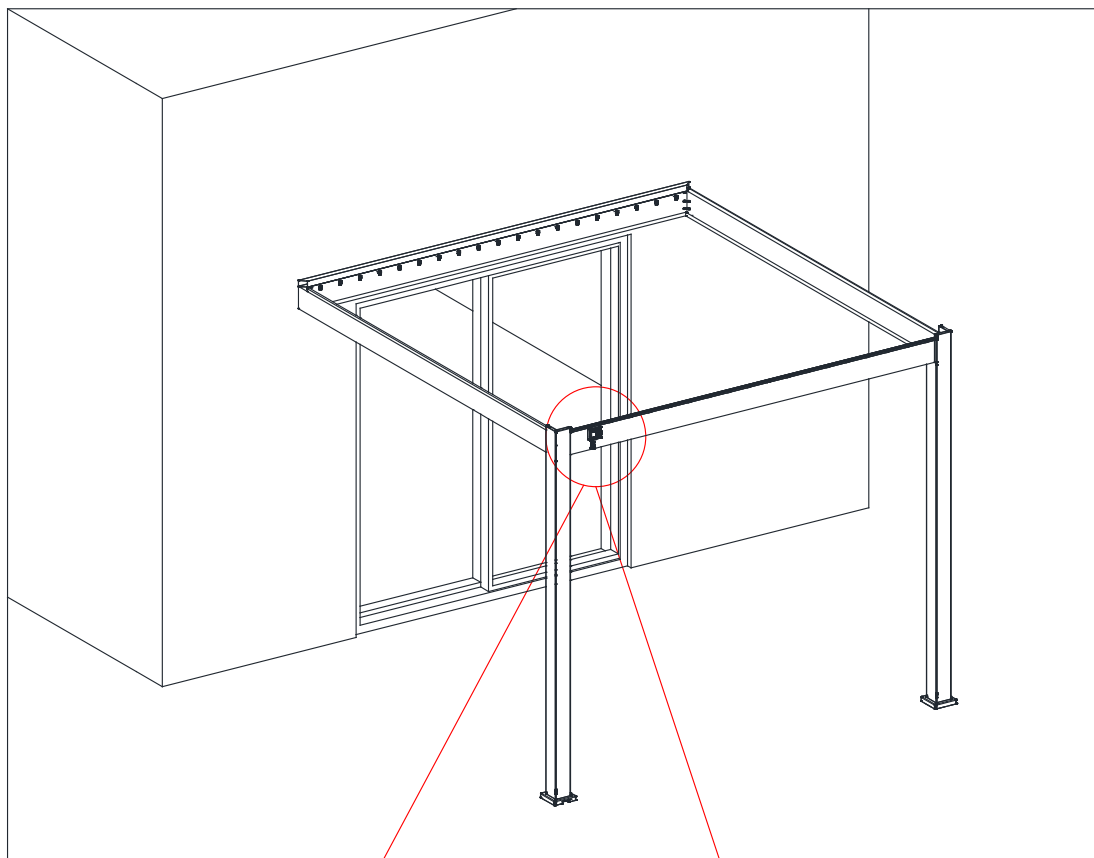

Fija la pérgola a un suelo de hormigón duro y plano, utilizando tacos de expansión **TO** y una broca de 12 mm (no suministrada).

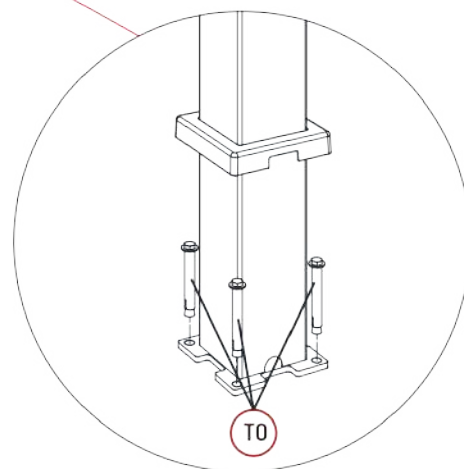
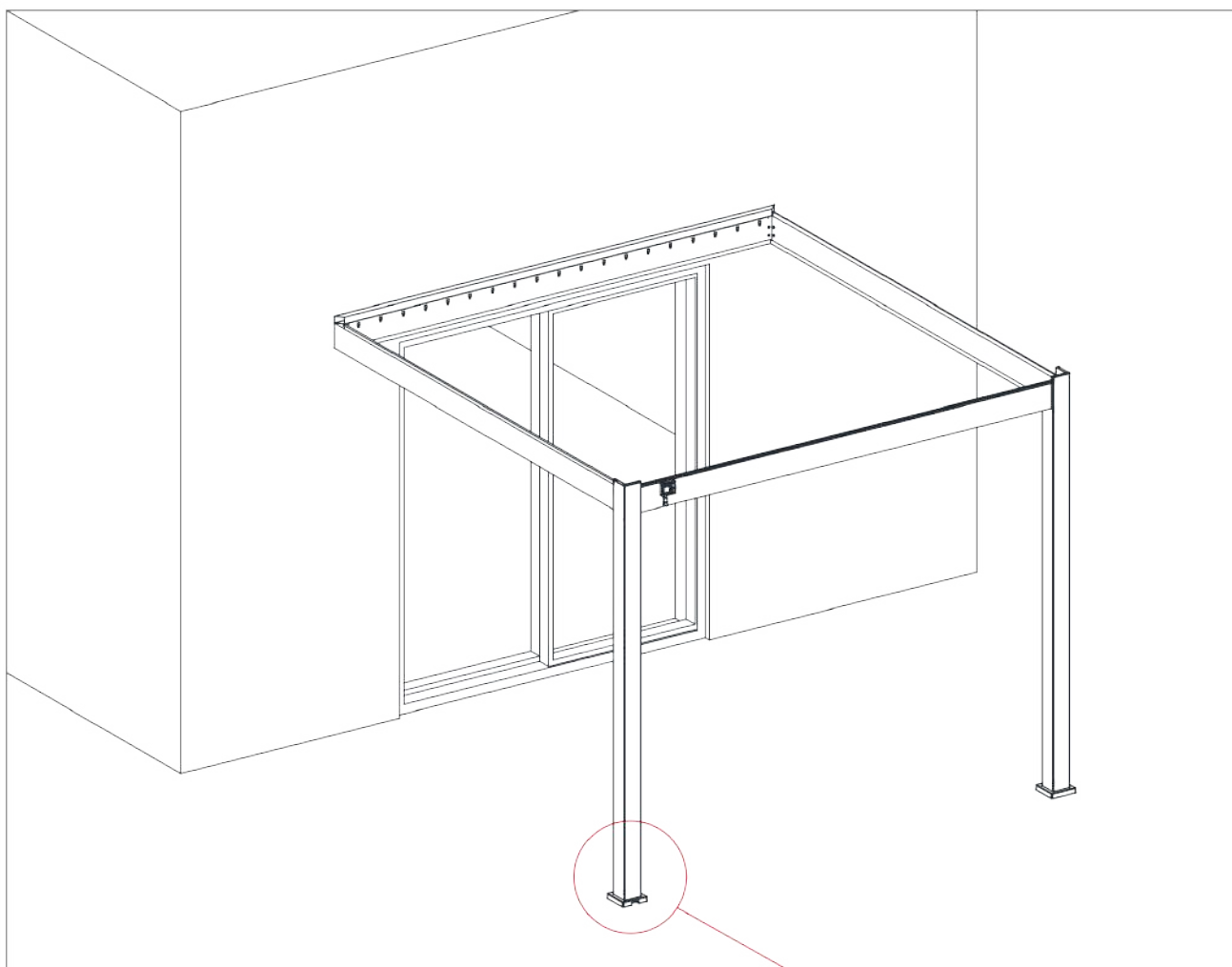

Confecciona y fija el pasador correspondiente al conjunto **XO**, **MO** y **UO** en las tapas de las lamas **LO** y **LO-1**. Asegúrate de que el pasador está instalado en la dirección correcta tanto para la pieza **LO** como para la **LO-1**, tal y como se muestra en el diagrama.

Utiliza un destornillador y la punta **ZO-2** para ayudar a insertar el perno **XO** en la tuerca **UO**. Para evitar lesiones y facilitar al máximo la operación, recomendamos sujetar la tuerca con la llave **ZO-5** durante la misma.

 **K0 X1**

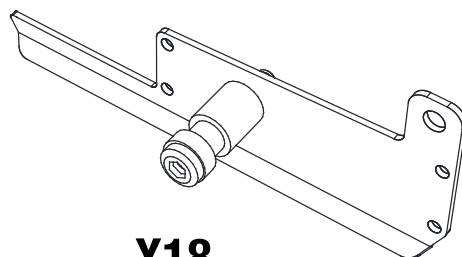
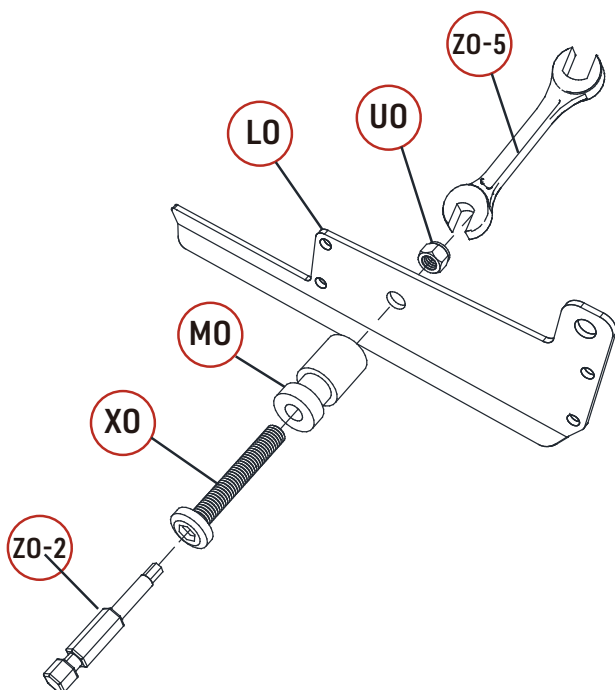
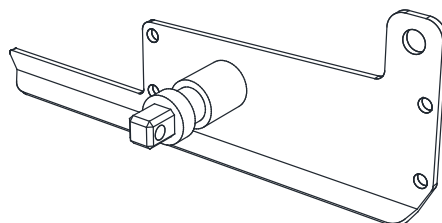

X18

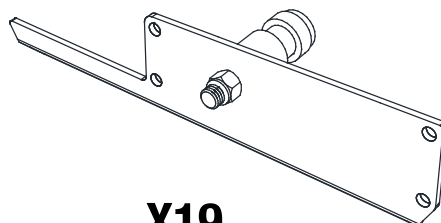
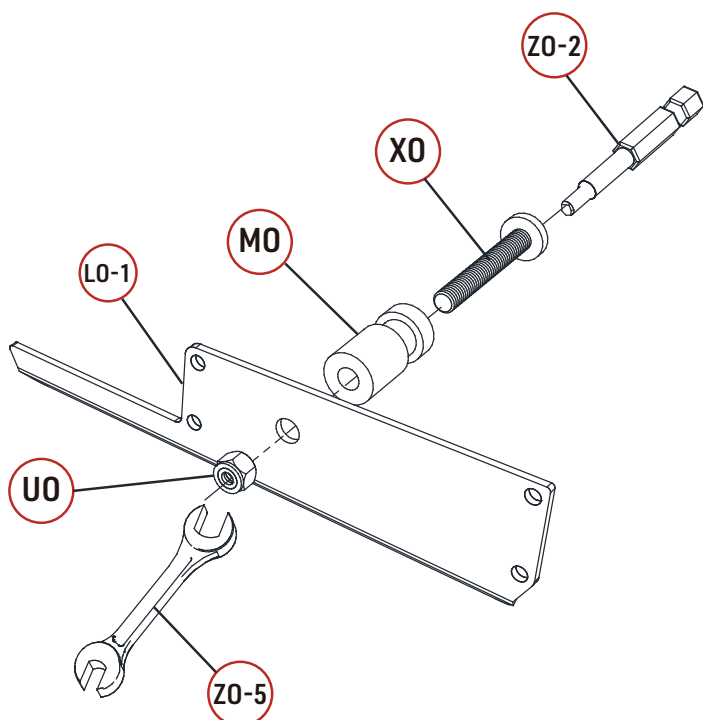

X19

Coloca la lama principal **GO** en la dirección correcta como se muestra en el diagrama, luego fija la tapa de la lama principal **KO** a la derecha de la lama y **LO-1** a la izquierda, con los tornillos **WO** utilizando un destornillador y la punta T20 **ZO-6**.

X1

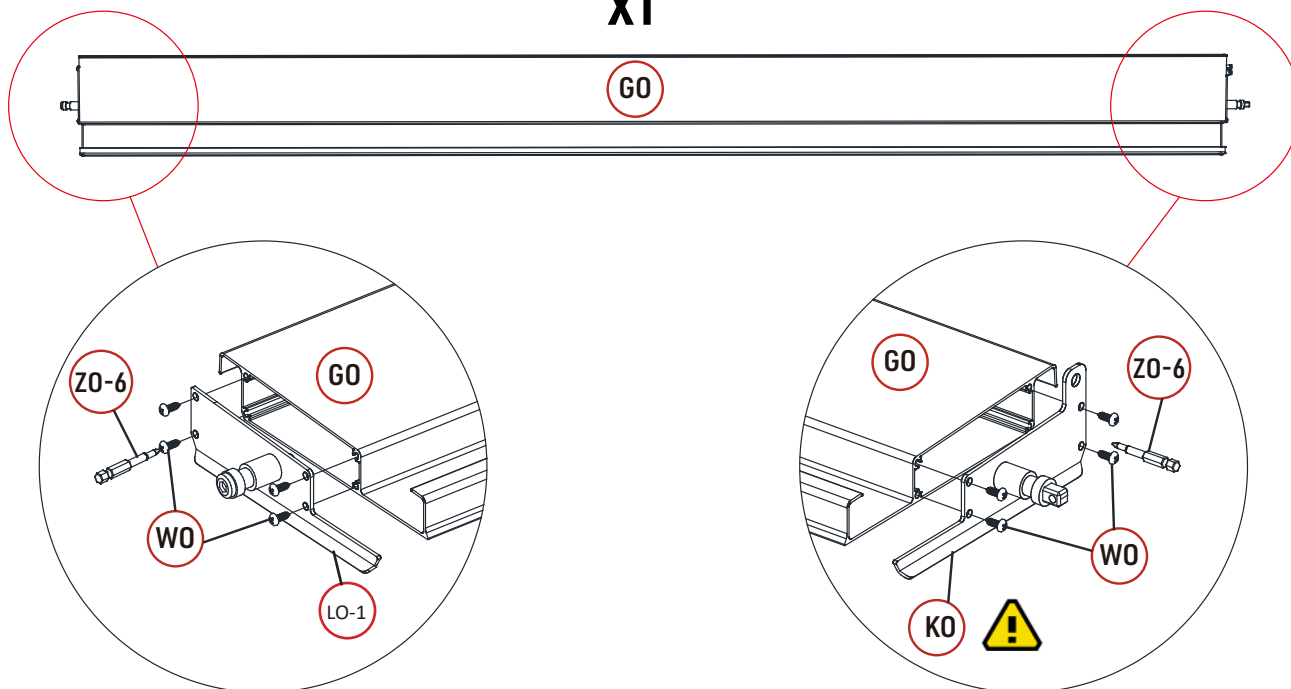

Repite la misma operación con las otras lamas **GO**, fijando las tapas de la lama **LO-1** a la izquierda y **LO** a la derecha.

X18

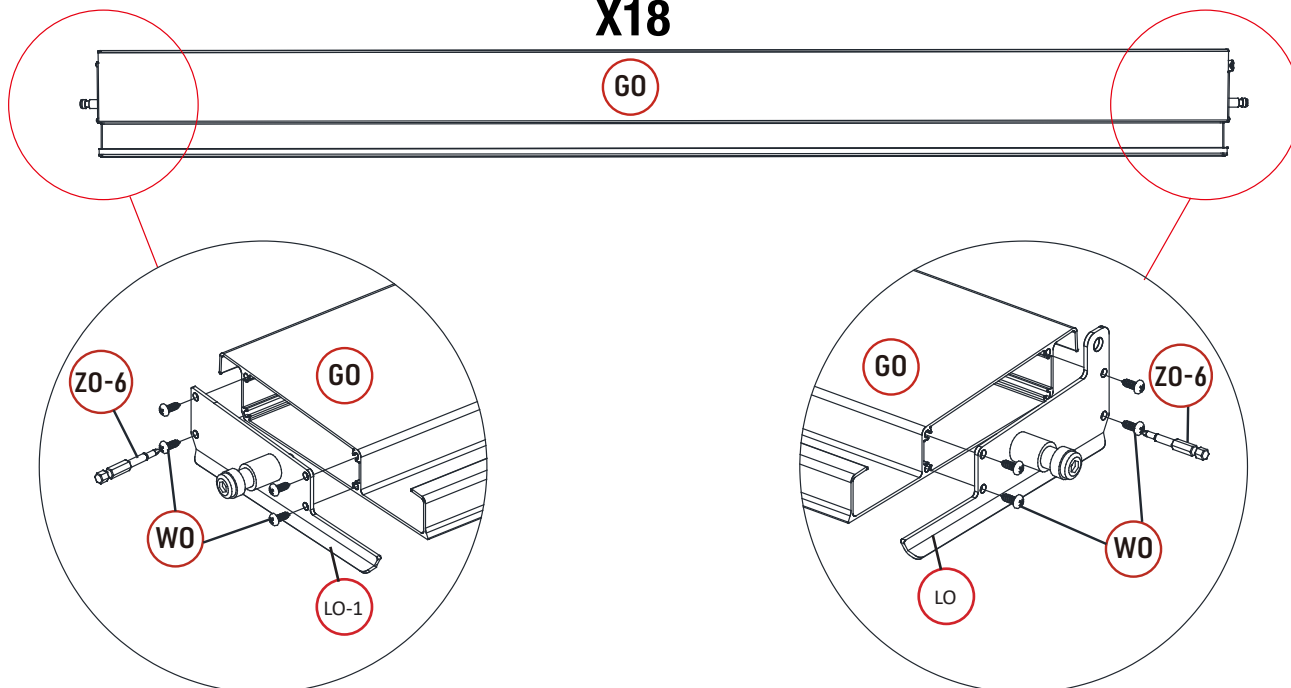

Instala la lama principal en la segunda posición del lugar previsto en la pérgola, empezando por el lado de la manivela para formar el techo.

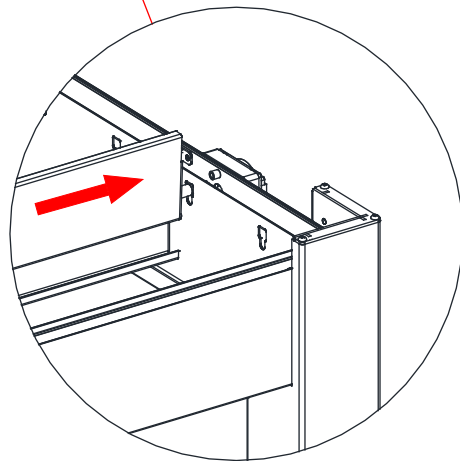
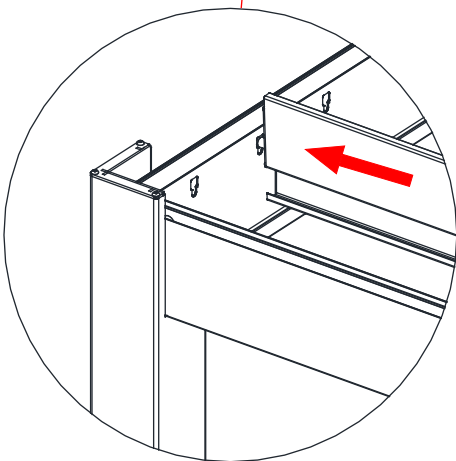
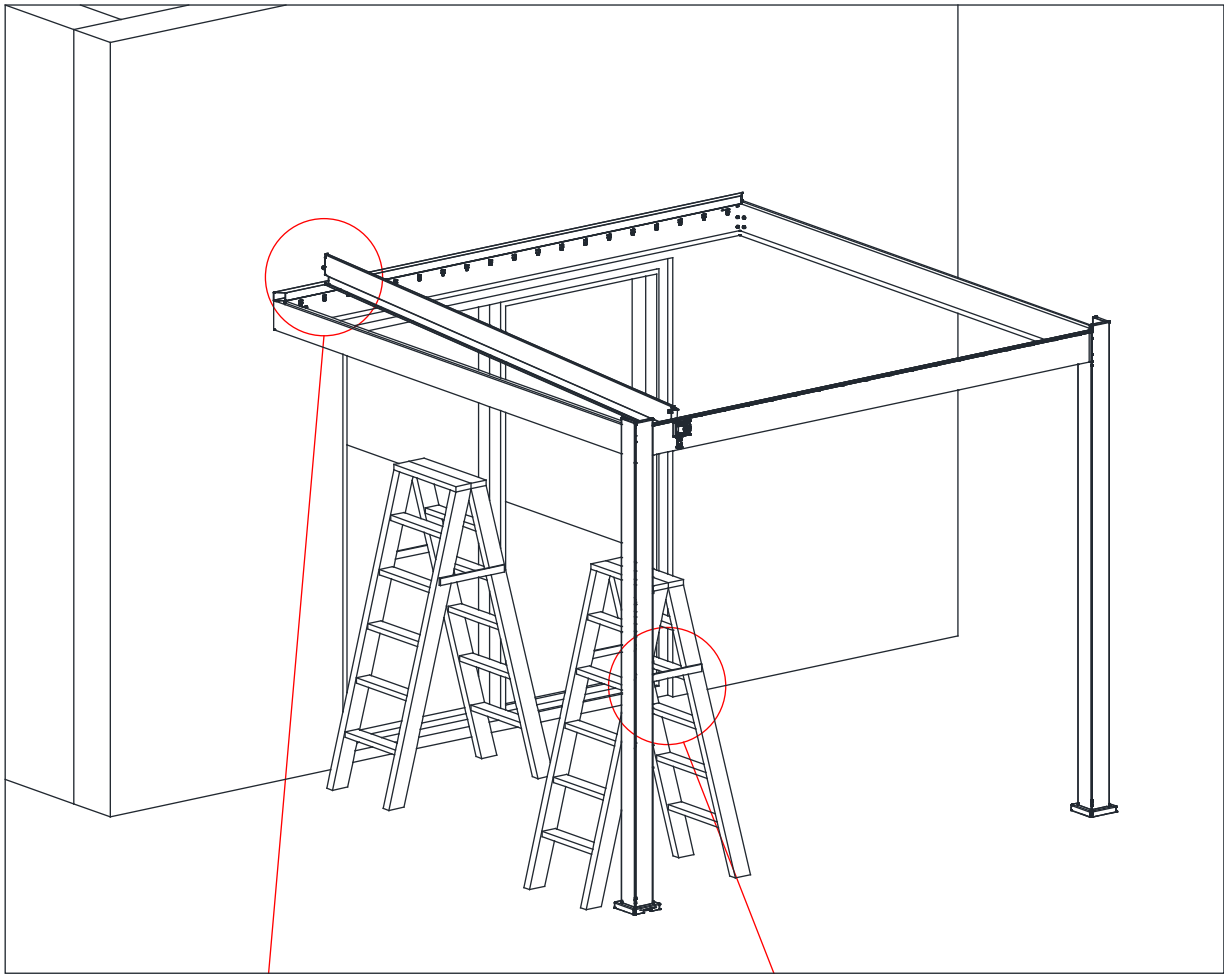

Introduce el cilindro **PO** en la caja de engranajes **NO** y a través de la viga, luego empuja hasta que encaje con el pasador de la lama principal.
Asegúrese de que el mecanismo manual funciona correctamente girando la lama hacia la derecha y luego hacia la izquierda con la manivela **HO**.

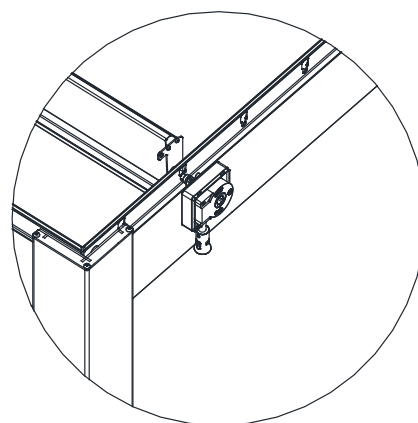
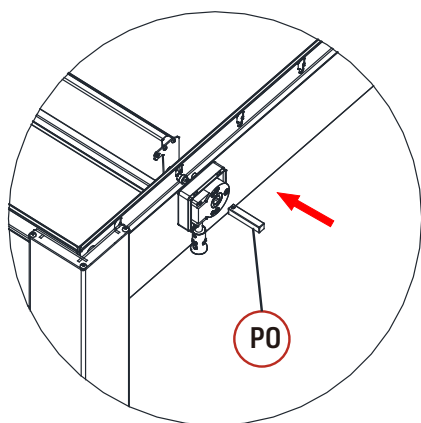
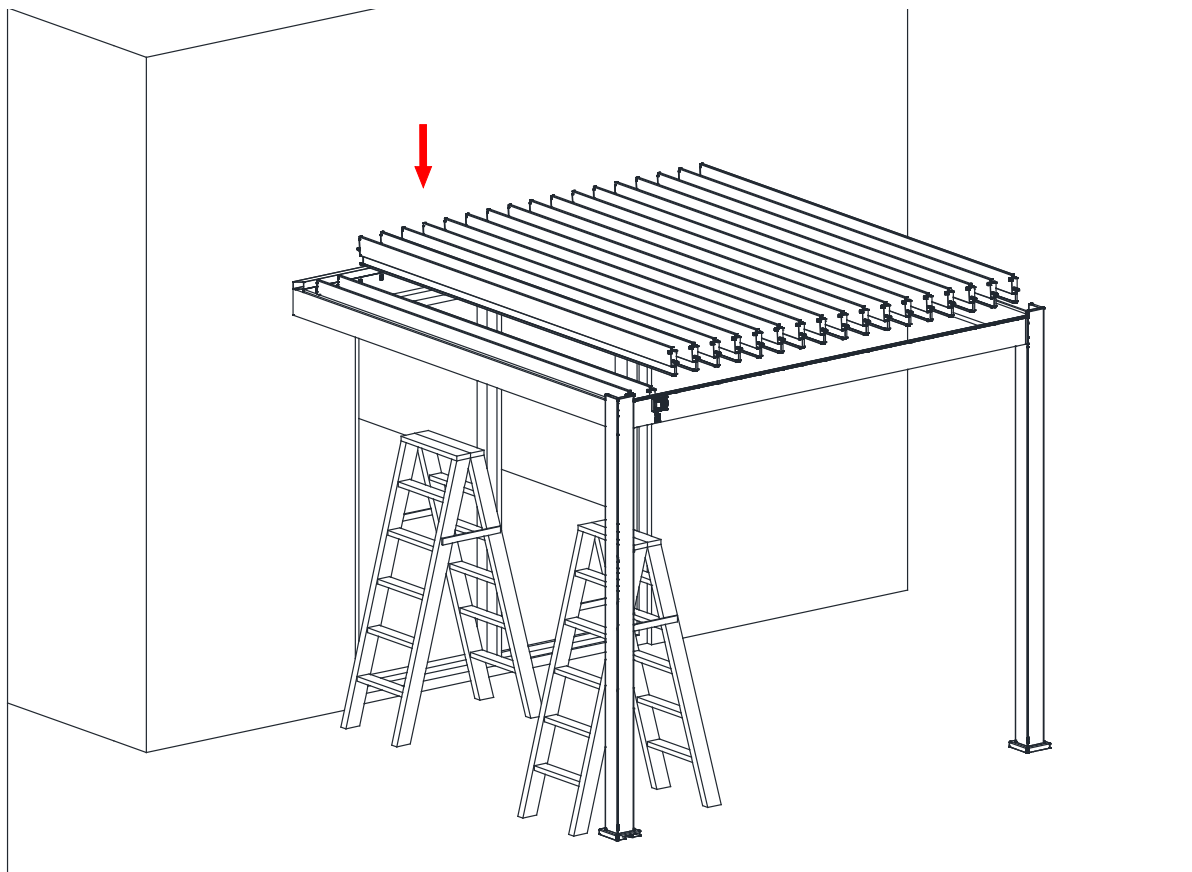

Coloque la lama en posición vertical, para poder instalar las demás lamas una tras otra.

Fija la barra de conexión **FO** en cada lama con las arandelas **VO** y la tuerca **UO** como se muestra, utilizando un destornillador y con la punta T20 **ZO-6** y la llave **ZO-5** para asegurar la tuerca.

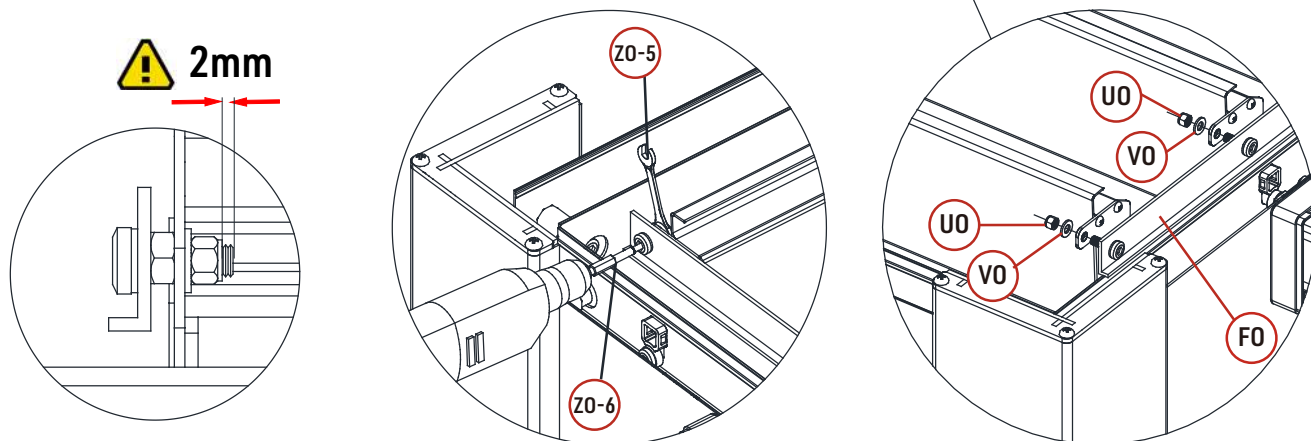
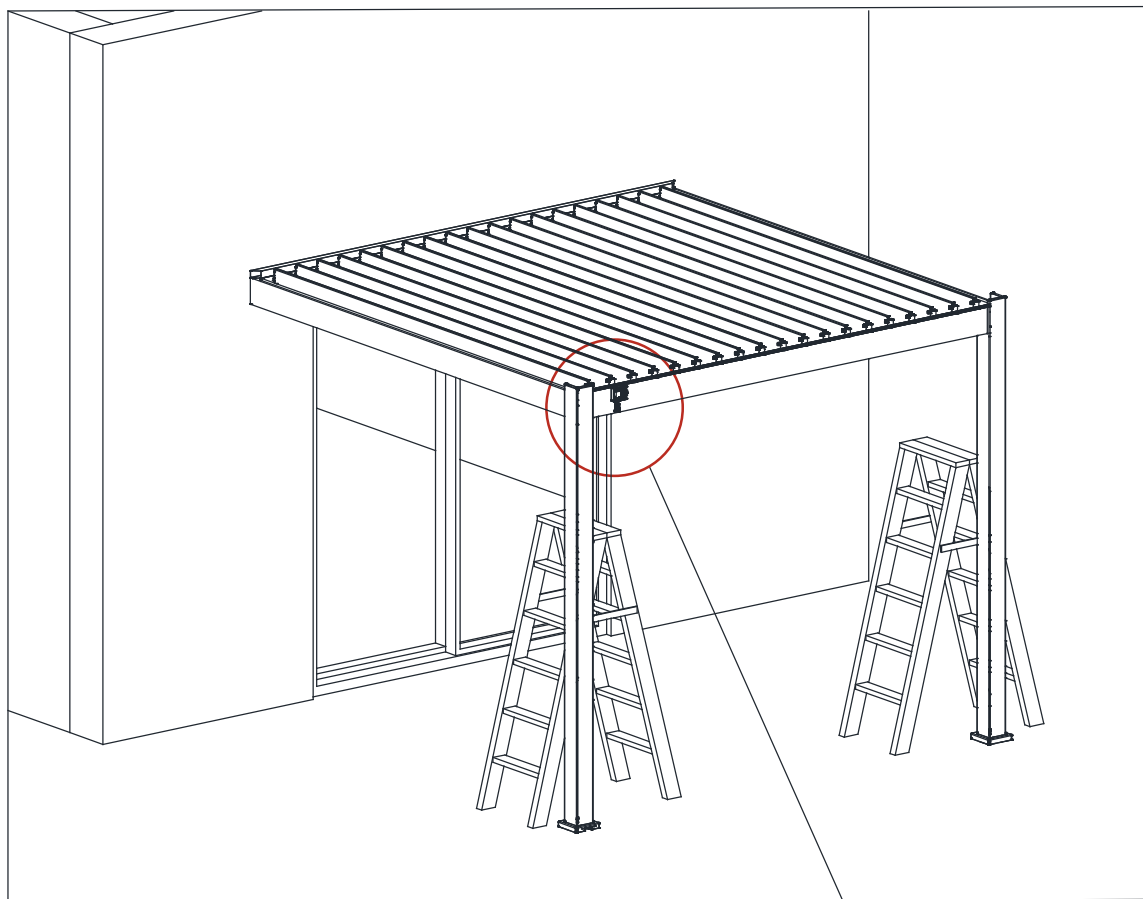

Coloca y ajusta las extensiones **DO-1**, **DO-3** y **DO-4** en las vigas como se indica en el diagrama.

A continuación, introduce las cuñas de media luna **SO**.

La abertura de la media luna debe estar en la parte inferior de la cuña.

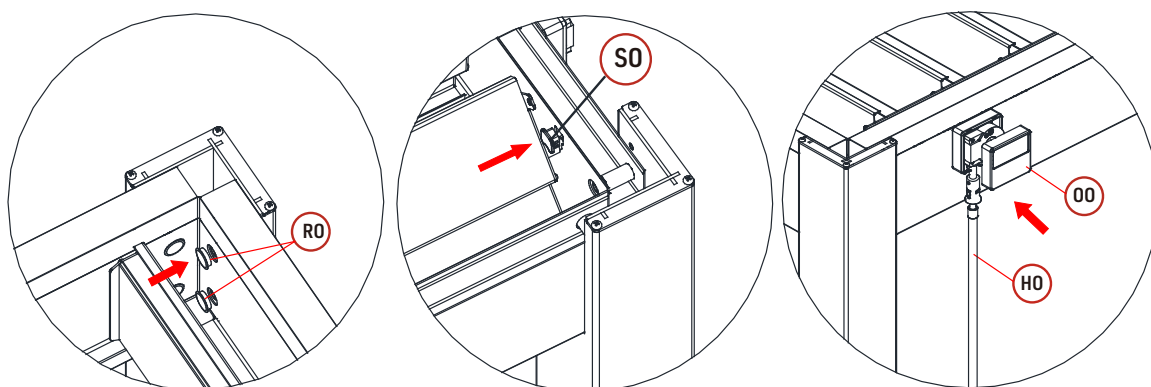
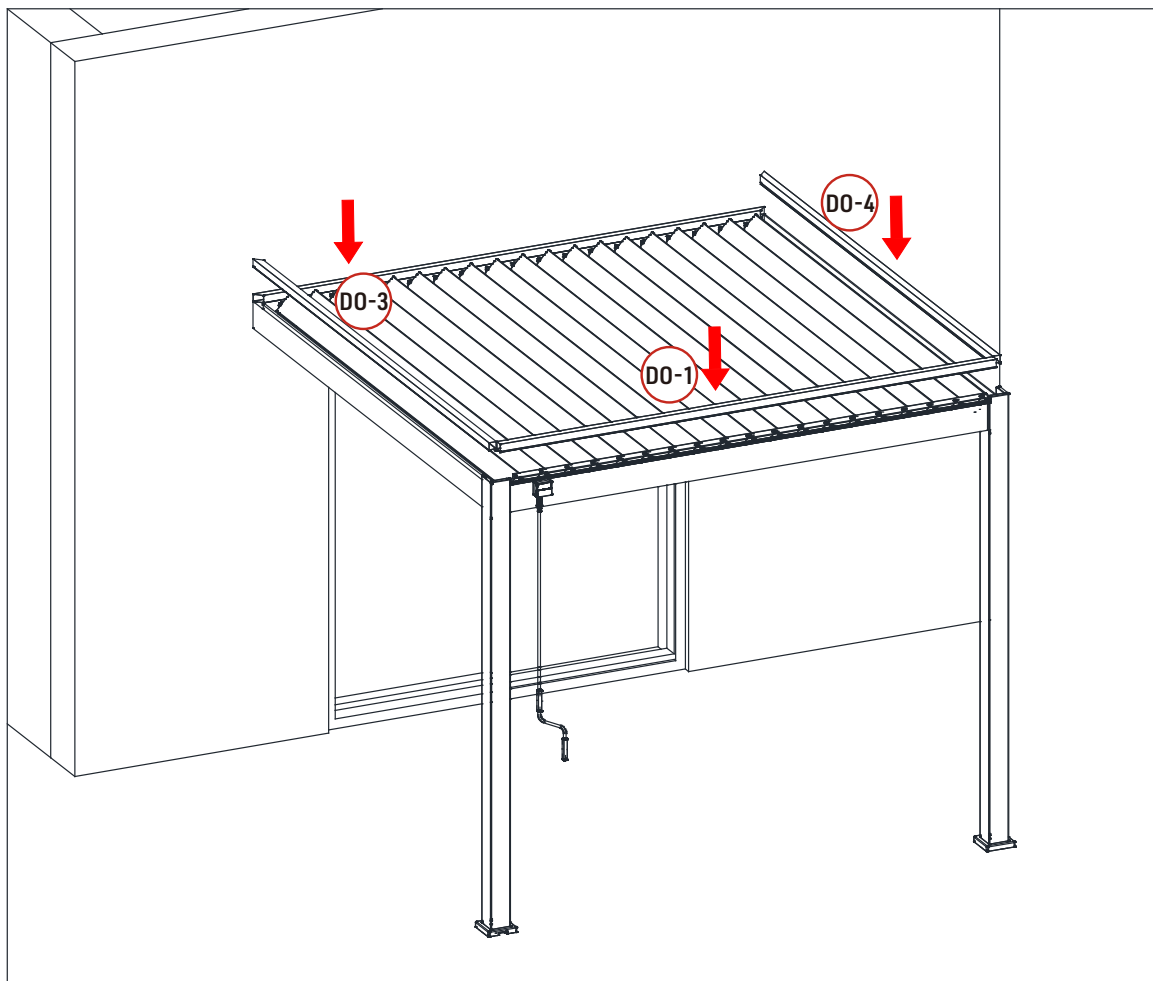

Inserta los botones de acabado **RO** para tapar los huecos que se encuentran en las esquinas del marco.

A continuación, engancha la segunda parte de la caja **OO** para cerrar y completa la instalación.

Pergola bioclimatica addossata 3x3M

Antracite: 15-728981 / **Bianco :** 15-729087

Istruzioni da conservare durante tutta la durata di vita del prodotto.

Vi chiediamo di leggere attentamente le istruzioni prima di procedere al montaggio.

L'utilizzatore sarà responsabile dei danni o infortuni causati da un utilizzo non conforme.

1. PRECAUZIONI D'UTILIZZO

Questo prodotto non deve essere utilizzato in caso di forti intemperie: temporali, venti violenti, grandine. Garantiamo la resistenza della pergola per dei venti fino a 100 km/h e un peso di neve fino a 50kg/m².

In caso di forti venti o nevicate, si consiglia vivamente di lasciare le lamelle aperte. In caso di dimenticanza, dovrete sgomberare la neve dalla pergola onde evitare un sovraccarico importante sulle lamelle.

La nostra pergola può sopportare le piogge forti, ma, non vi possiamo garantire un'impermeabilità al 100%.

Nel caso di episodi climatici eccezionali, l'impermeabilità può essere compromessa. Non lasciate i prodotti sensibili all'umidità sotto la pergola. Non montare sul tetto né sulla struttura della pergola.

2. CONSIGLI DI MONTAGGIO

A seconda dell'ubicazione e della superficie, le costruzioni possono essere soggette a dichiarazioni di lavori o a richieste di permessi di costruzione. Vi invitiamo a contattare il vostro municipio per ottenere le informazioni necessarie prima dell'installazione.

Montaggio del prodotto:

- 2 a 3 persone sono necessarie
- Togliere la pellicola di protezione
- Non lasciare i bambini giocare a prossimità della zona di montaggio
- Attenzione ai rischi di schiacciamento
- Mai stringere completamente le viti prima di aver assemblato tutta la parte interessata
- Tutte le fasi di assemblaggio devono essere eseguite con attenzione
- Controllare i livelli, le diagonali e l'equilibrio della struttura
- Fissare la pergola solo dopo averla montata

Nessuna modifica può essere apportata al prodotto. I prodotti modificati dall'utilizzatore non sono più coperti dalla garanzia del fabbricante.

Il luogo di ubicazione deve essere scelto in maniera appropriata. Si raccomanda di evitare di montare la pergola di fronte ai venti dominanti e sotto un albero.

La pergola dev'essere montata su una base adeguata, stabile e livellata, si consiglia di installarla su una lastra di cemento o su dei blocchi di cemento 25x25 cm ad ogni palo. Vi chiediamo di ancorare correttamente la pergola al suolo utilizzando i pezzi TO.

Se desiderate posizionare la vostra pergola a ridosso della vostra casa o di un'abitazione, vi chiediamo di controllare la presenza di grondaie per lo scorrimento dell'acqua. La pergola Ombréa® non potrà sopportare e garantire un'impermeabilità perfetta se le acque piovane della vostra abitazione defluiscono sopra.

In caso di non rispetto delle raccomandazioni di montaggio, la garanzia non potrà applicarsi.

3. MANUTENZIONE DELLA PERGOLA

Una manutenzione periodica è necessaria per assicurare la longevità e l'aspetto estetico. Vi raccomandiamo di:

- Lavare la vostra pergola 1 a 2 volte all'anno con dell'acqua dolce e una spugna o un panno. Non utilizzare prodotti corrosivi o un supporto abrasivo.
- Controllare regolarmente il serraggio delle viti (almeno 1 volta all'anno)
- Oliare i pezzi di ferramenta (almeno 1 volta all'anno)
- Assicurarsi che il flusso dell'acqua delle grondaie non sia ostruito (foglie, rami, ecc.)
- Togliere l'acqua che potrebbe stagnare attorno ai piedi della pergola (sollevare le protezioni).

4. GARANZIA

Ombréa® garantisce la disponibilità dei pezzi di ricambio per 2 o 5 anni (a seconda del prodotto). La garanzia si applica solo se le istruzioni di stoccaggio, montaggio, utilizzo, manutenzione vengono rispettate.

La garanzia non copre :

- L'usura normale inerente ai prodotti.
- La perdita o il danno di qualsiasi pezzo durante il disimballaggio o l'installazione.
- La mancanza di manutenzione ragionevole, la negligenza, il vandalismo, l'impatto con degli oggetti esterni, l'uso della forza, il contatto con degli abrasivi, l'estetismo, lo smontaggio, la ricostruzione o la rilocalizzazione.
- Casi di forza maggiore: grandine, venti forti, tempeste, neve, inondazioni, fulmine...
- Prodotto modificato dall'utilizzatore.

La garanzia comprende soltanto la sostituzione del pezzo di ricambio o del prodotto fornito, esclude le spese, costi e indennità di qualsiasi tipo.

Qualsiasi richiesta di garanzia deve essere effettuata presso il punto vendita (negoziario o sito internet) dove è stato comprato il prodotto.

5. ELENCO DELLE PARTI (PER CARTONE)





Prima di procedere al montaggio della vostra pergola bioclimatica, è necessario controllare che tutte le parti siano presenti e non siano danneggiate.

Eventuali parti mancanti devono essere segnalate entro i 10 giorni dall'acquisto. Questo può essere fatto attraverso il vostro rivenditore o direttamente facendo una richiesta sul nostro sito sav.comintes.com.

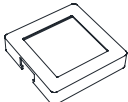

Non buttare l'imballaggio senza assicurarsi del corretto funzionamento della pergola.

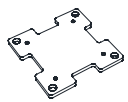
COLLO 1/4 (PALI E FERRAMENTA)



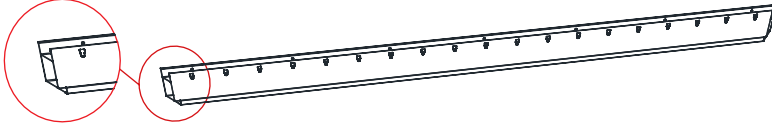

| Riferimento | Schema | Quantità |
|-------------|--|----------|
| AO |  PALO | 2 |







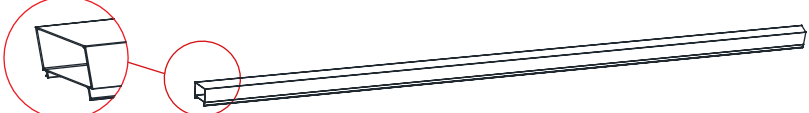



| Riferimento | Schema | Quantità | Riferimento | Schema | Quantità |
|-------------|--|----------|-------------|--|----------|
| IO |  COPERCHIO PIASTRA | 2 | TO |  M8x80 TASSELLO PER CEMENTO | 8 |
| JO |  PIASTRA DI ANCORAGGIO | 2 | XO-1 |  6x35 BULLONE 6x35 | 8 |

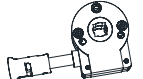

COLLO 2/4 (TRAVI E FERRAMENTA)

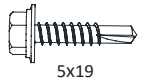
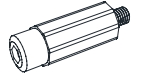

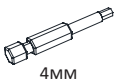
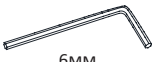
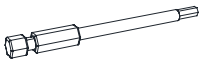

| Riferimento | Schema | Quantità |
|-------------|---|----------|
| BO-1 |  TRAVE PRINCIPALE | 1 |
| BO-2 |  TRAVE POSTERIORE | 1 |
| CO-1 |  TRAVE LATERALE (SINISTRA) | 1 |
| CO-2 |  TRAVE LATERALE (DESTRA) | 1 |

COLLO 2/4 (TRAVI E FERRAMENTA)

| Riferimento | Schema | Quantità |
|-------------|--|----------|
| DO-1 |  ESTENSIONE DELLA TRAVE (ANTERIORE) | 1 |
| DO-2 |  ESTENSIONE DELLA TRAVE (POSTERIORE) | 1 |
| DO-3 |  ESTENSIONE DELLA TRAVE LATERALE (SINISTRA) | 1 |
| DO-4 |  ESTENSIONE DEL FASCIO LATERALE (DESTRA) | 1 |
| FO |  BARRA DI CONNESSIONE (VITI INCLUSE) | 1 |
| HO |  MANOVELLA | 1 |

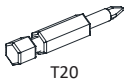
| Riferimento | Schema | Quantità | Riferimento | Schema | Quantità |
|-------------|--|----------|-------------|---|----------|
| LO-2 |  ANGOLO DI PLASTICA | 2 | UO |  DADO | 56 |
| NO |  GEARBOX | 1 | VO |  RONDELLA | 19 |
| OO |  SCATOLA | 1 | XO |  6x40 BULLONE 6X40 | 37 |
| PO |  CILINDRO | 1 | XO-2 |  5x19 VITE AUTOFILETTANTE 5X19 | 8 |
| QO |  VITI DI FISSAGGIO DELLA TRAVE | 8 | YO |  6x45 BULLONE 6X45 | 3 |
| RO |  TAPPO DI FINITURA | 8 | ZO-1 |  4MM CHIAVE ALLEN DA 4 MM | 1 |
| SO |  CUNEO A MEZZALUNA | 38 | | | |



| Riferimento | Schema | Quantità |
|-------------|---|----------|
| ZO-2 |  4MM PUNTA DI CACCIAVITE DA 4 MM | 1 |
| ZO-3 |  6MM CHIAVE ALLEN DA 6 MM | 1 |
| ZO-4 |  6MM PUNTA DI CACCIAVITE DA 6 MM | 1 |
| ZO-5 |  10MM CHIAVE PIATTA 10 MM | 1 |

| Riferimento | Schema | Quantità |
|-------------|---|----------|
| ZO-6 |  T20 PUNTA DI CACCIAVITE T20 | 1 |
| ZO-7 |  PUNTA | 1 |
| ZO-8 |  COLLA | 1 |
| TO-1 |  TASSELLO 8X100 | 1 |

COLLO 3/4 (LAMELLE E FERRAMENTA)

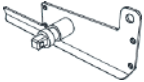
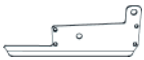
| Riferimento | Schema | Quantità |
|-------------|---|----------|
| GO |  LAMA | 9 |

| Riferimento | Schema | Quantità |
|-------------|---|----------|
| KO |  COPRI-LAMELLA PRINCIPALE | 1 |
| LO |  COPRI-LAMELLA A | 18 |

| Riferimento | Schema | Quantità |
|-------------|--|----------|
| LO-1 |  COPRI-LAMELLA B | 19 |
| MO |  PERNO | 37 |

| Riferimento | Schema | Quantità |
|-------------|--|----------|
| WO |  4x16 VITI 4X16 | 152 |

COLLO 4/4 (LAMELLE)

| Riferimento | Schema | Quantità |
|-------------|--|----------|
| GO |  LAMA | 10 |

Le parti in alluminio sono le seguenti: AO, BO-1, BO-2, CO-1, CO-2, DO-1, DO-2 DO-3, DO-4, FO, GO, IO, KO, LO et LO1.

Le viti e le altre parti sono in acciaio inox, acciaio zincato, plastica o nylon.

Per ulteriori informazioni, consultate le specifiche tecniche del prodotto e la pagina delle FAQ all'indirizzo www.pergola-ombrea.com o contattate il proprio rivenditore.

6. MATERIALE (NON FORNITO) NECESSARIO PER IL MONTAGGIO



Occhiali e guanti protettivi



2 scalette



Trapano a percussione + punta per cemento da 12 mm



Trapano avvitatore

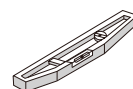

Livella



Taglierino



Elmetto

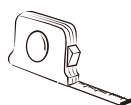

Metro a nastro



Colla

7. CONTATTO

Desiderosi di migliorare, non esitate a inviarci i vostri commenti e suggerimenti al seguente indirizzo: contact@pergola-ombrea.com

Saremo lieti di ricevere i vostri migliori scatti della vostra installazione.

Il team Ombréa vi ringrazia per l'acquisto e vi augura giorni felici sotto la vostra pergola!

8. PIANO DI MONTAGGIO (dimensioni in mm)

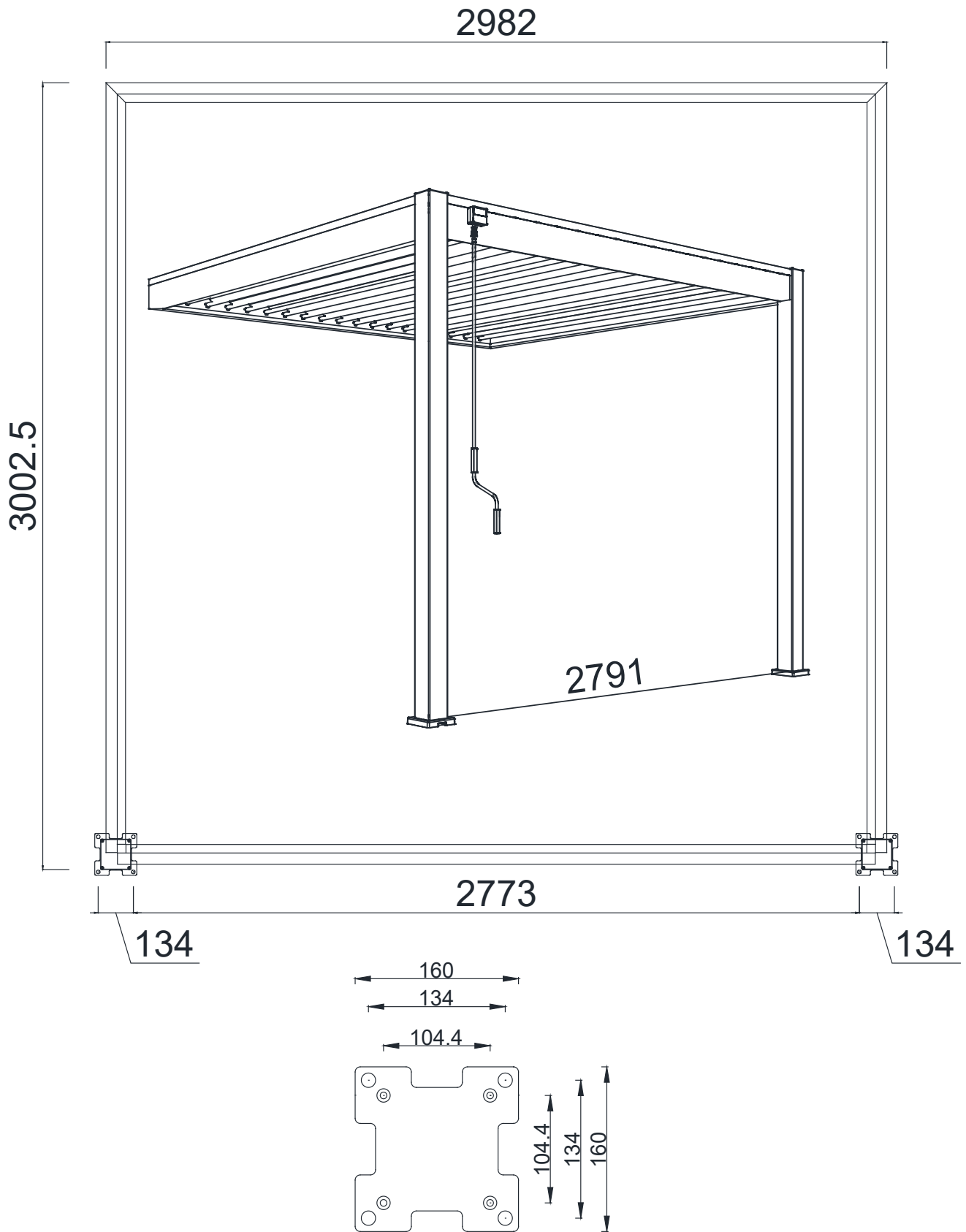

9. TAPPE DEL MONTAGGIO

Per evitare di danneggiare la vostra pergola durante il montaggio, si consiglia di assemblarla su un tavolo, dei cavalletti o una superficie piana e pulita.

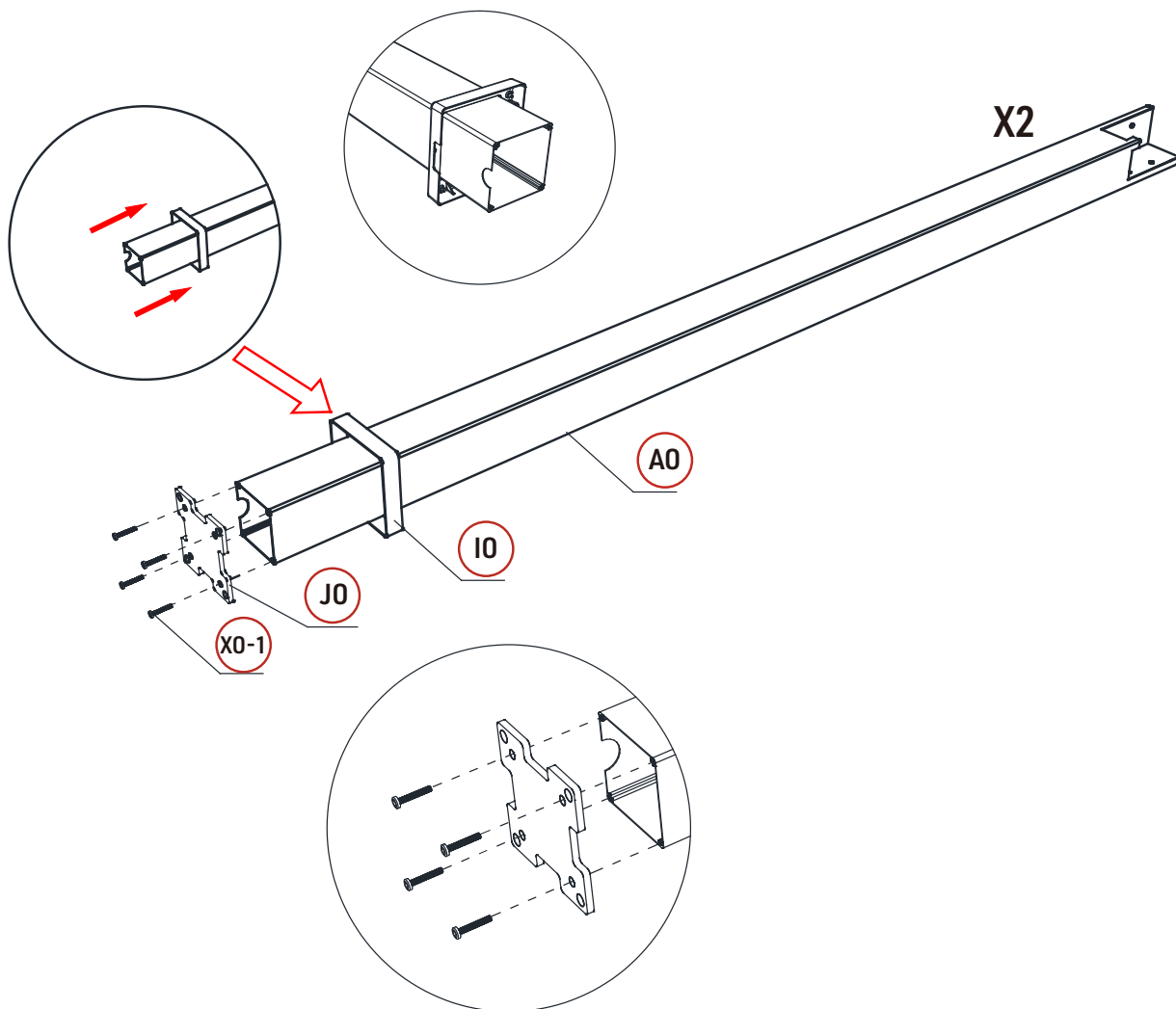

Fate scorrere i coperchi **IO** sui montanti **AO**, posizionando l'apertura nella stessa direzione dell'apertura nel montante a forma di mezzaluna.

Fissare quindi la piastra **JO** con le viti **XO-1** utilizzando l'avvitatore. Iniziate ad avvitare leggermente, completate l'operazione fino in fondo quando tutte le viti sono in posizione.

Separate le estensioni **DO-1**, **DO-2**, **DO-3** e **DO-4** dalle travi **BO-1**, **BO-2**, **CO-1** e **CO-2**. Mettete da parte le parti rimosse per un secondo momento.

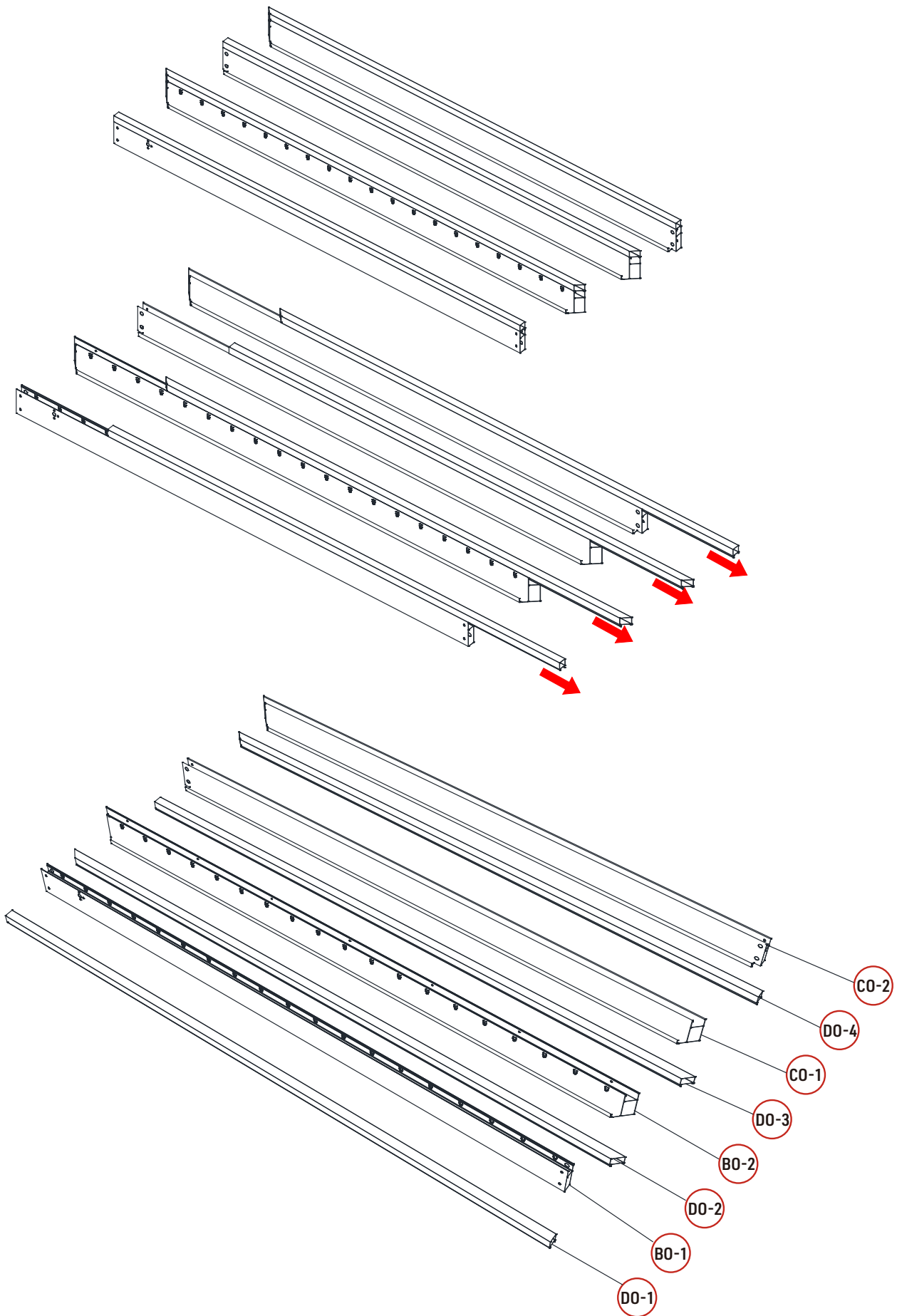

Inserite gli angoli **LO-2** nella trave murale **BO-2** e avvitateli come indicato nello schema con le viti autoperforanti **XO-2**, utilizzando l'avvitatore e la punta **ZO-7**.

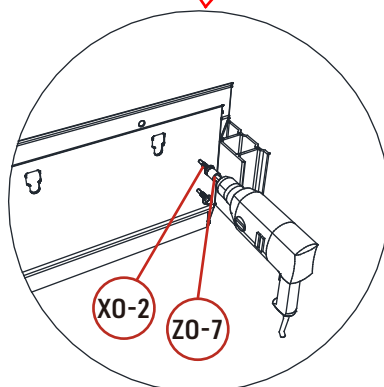
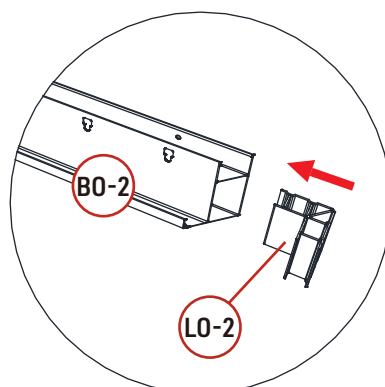
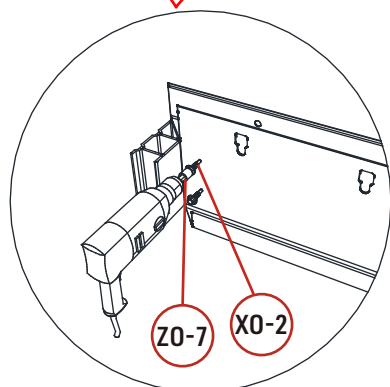
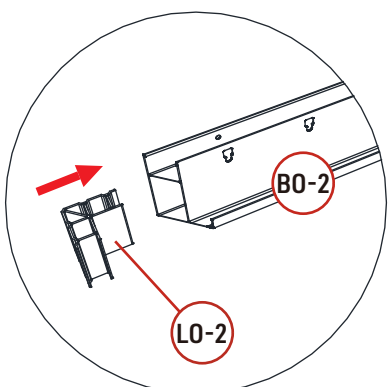

Su una parete, posizionate la trave murale **BO-2** sulla facciata a un'altezza di 237 cm.

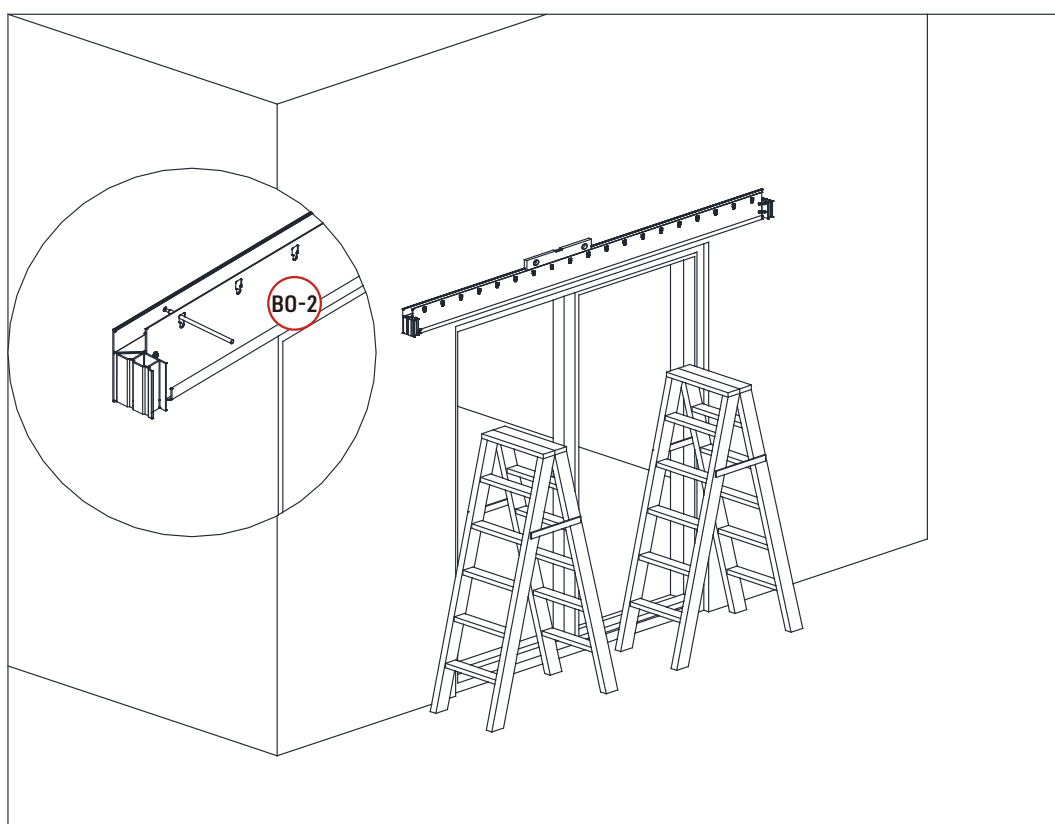

Con l'aiuto di 2/3 persone, utilizzando una livella, assicuratevi che la trave murale **BO-2** sia diritta e con una matita segnate i fori, prima di rimuovere la trave.

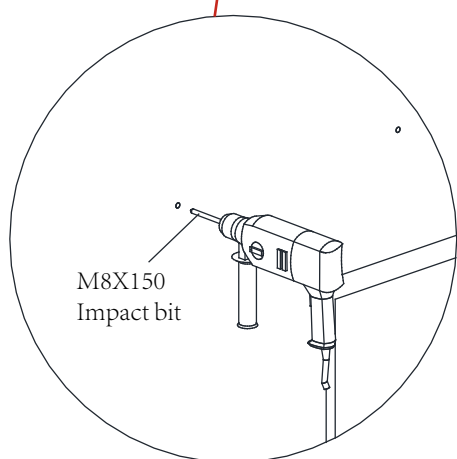
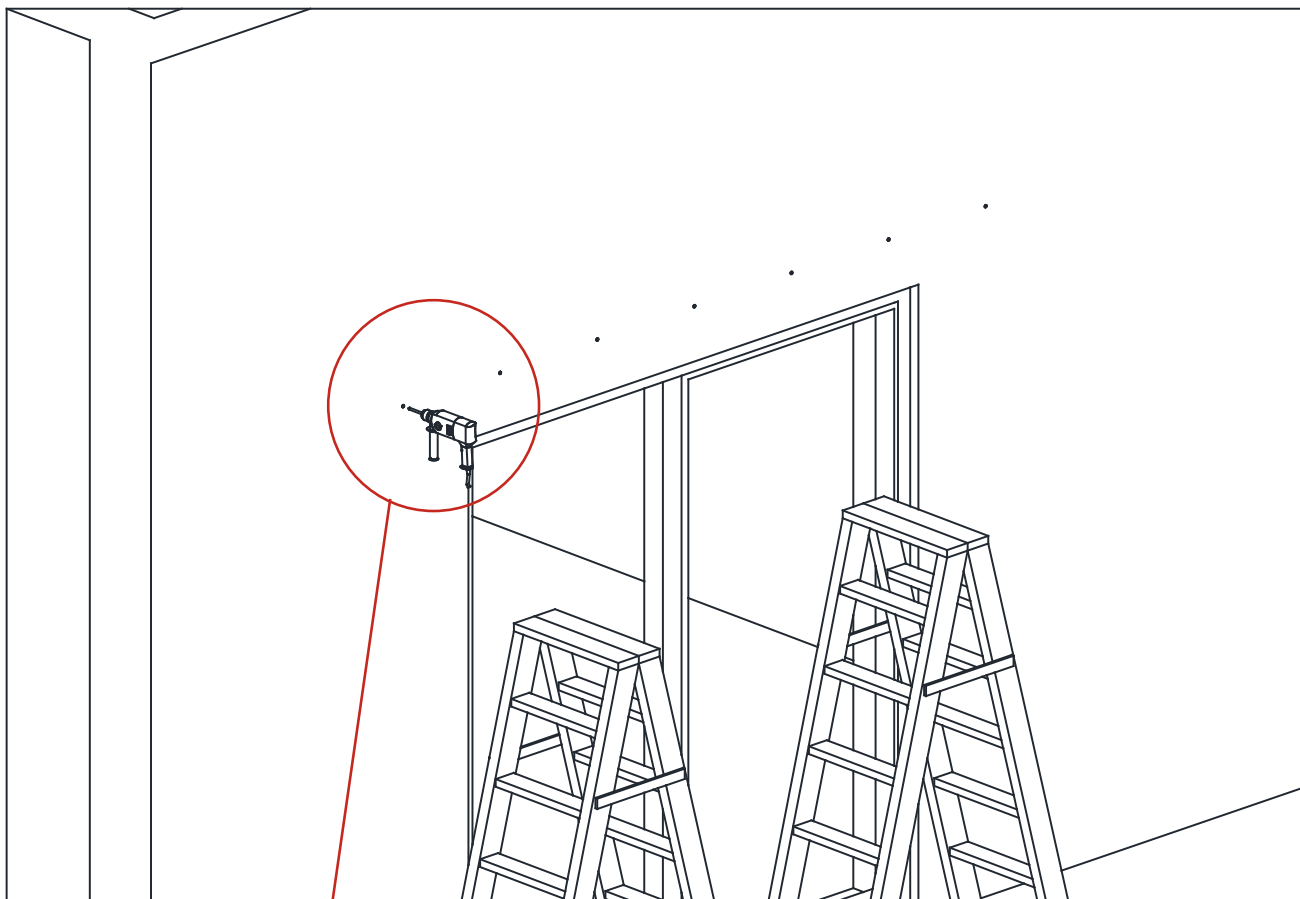

Forate il muro nei punti segnati a matita con un trapano e una punta M8x150.

Suggerimento: per ottenere la massima tenuta all'acqua, si consiglia di applicare della colla tra la parete e la trave murale.

Riposizionate la trave murale **BO-2** e mantenetela in piano in modo che sia dritta. Inserite quindi i tasselli **TO-1** come indicato nello schema.

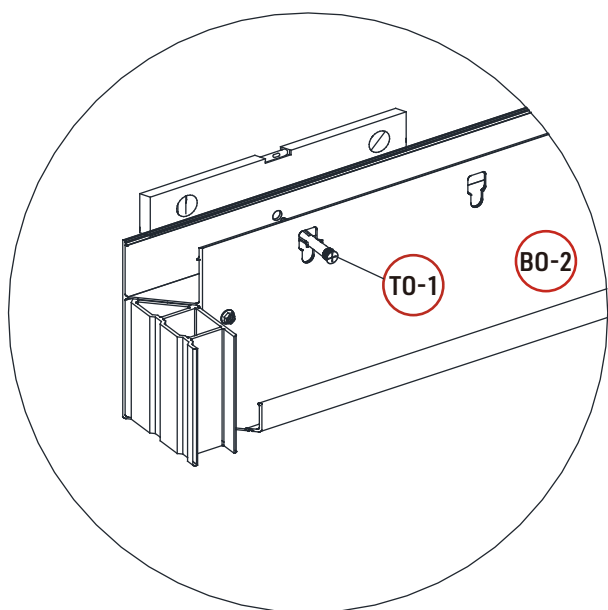
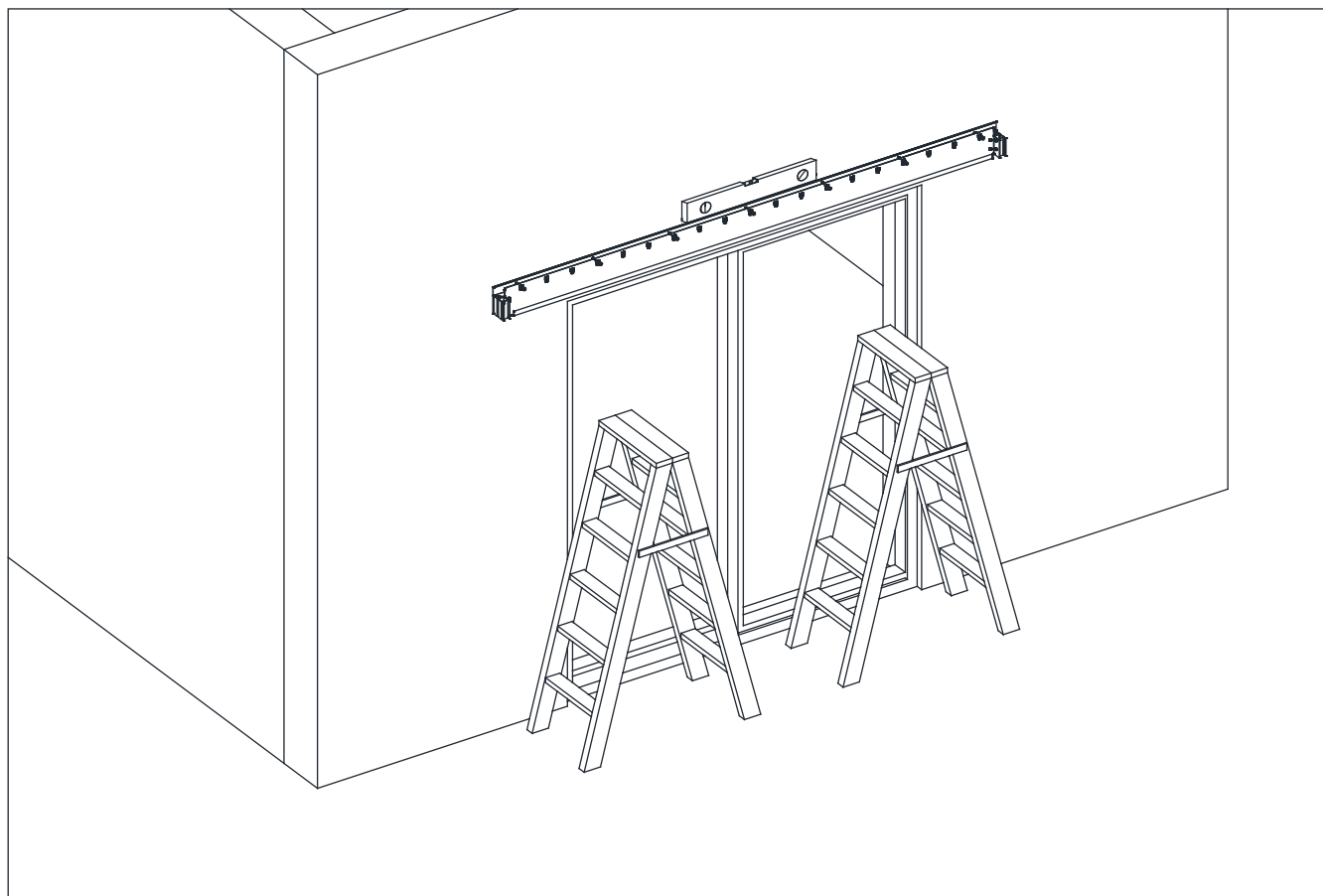

Incastrate l'estensione della trave **DO-2** alla trave murale **BO-2**.

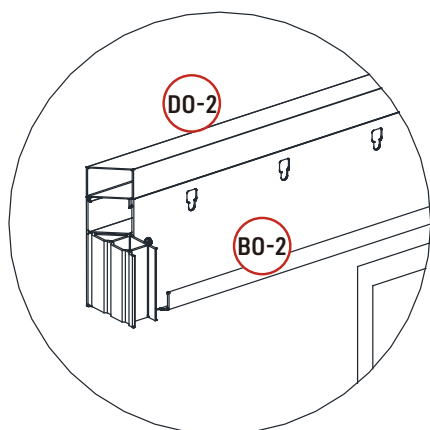
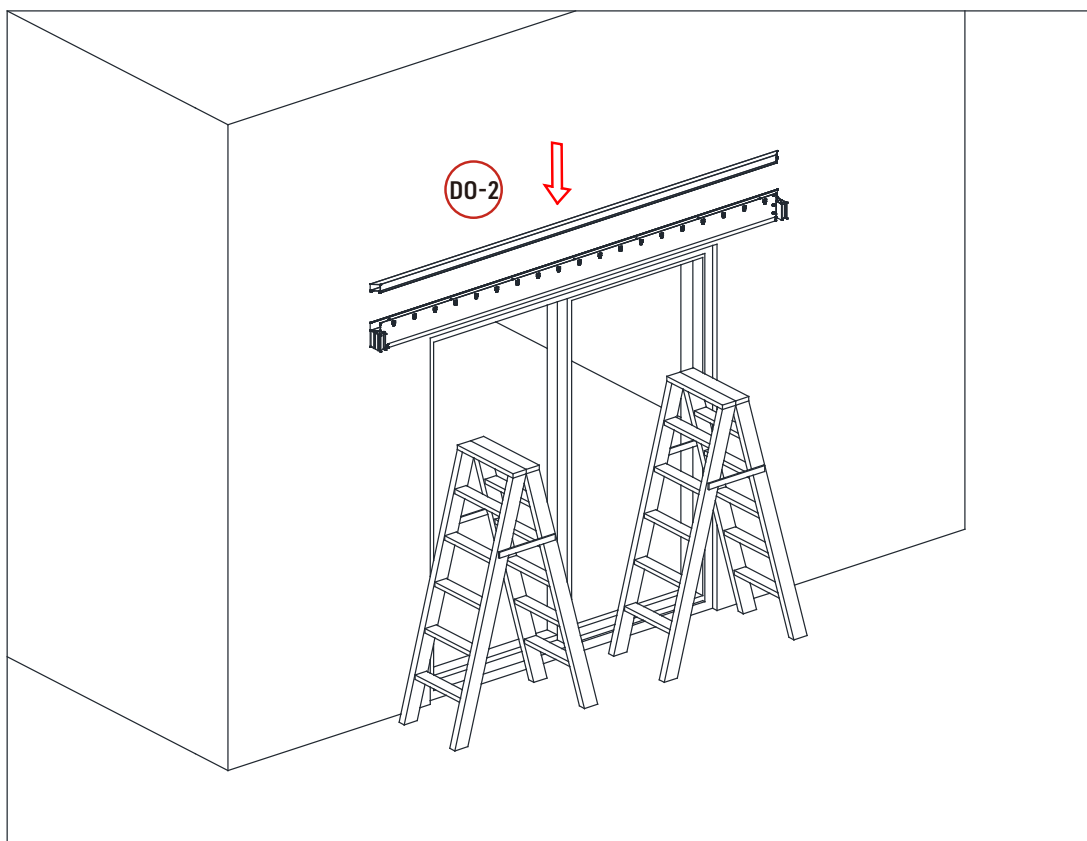

Come indicato nello schema, fissate le travi **CO-1** e **CO-2** ai montanti **AO** con le viti **QO**, utilizzando un avvitatore e la punta **ZO-4** o la chiave Allen **ZO-3**.

Raccordate l'insieme alla trave murale **BO-2** incastrandola nella parte **LO-2**.

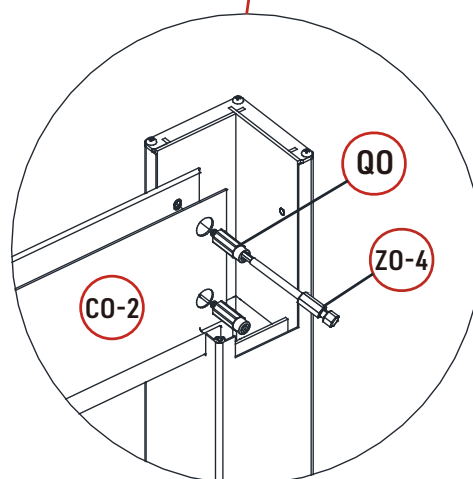
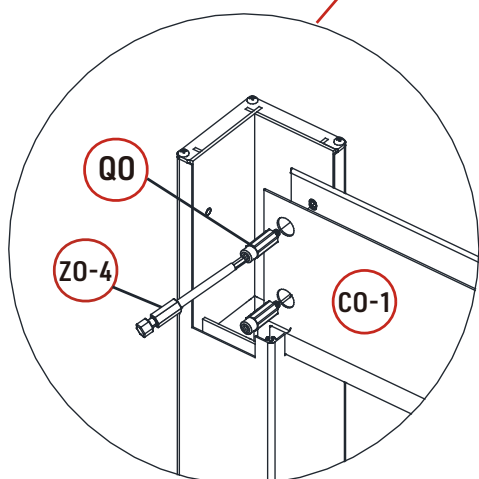
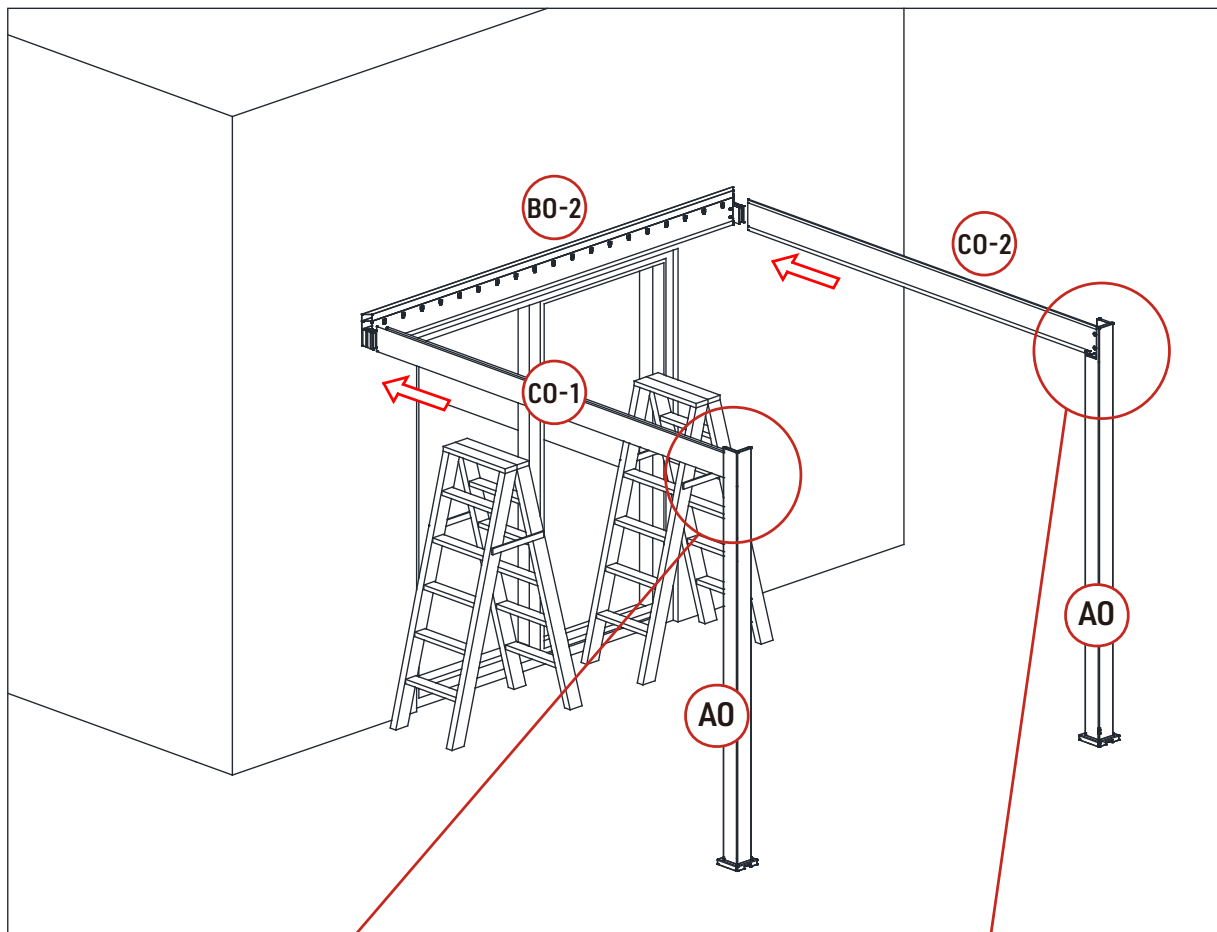

Fissate le travi laterali **CO-1** e **CO-2** su entrambi i lati alla parte **LO-2** con le viti autoperforanti **XO-2** come indicato nello schema, utilizzando un avvitatore e la punta **ZO-7**.

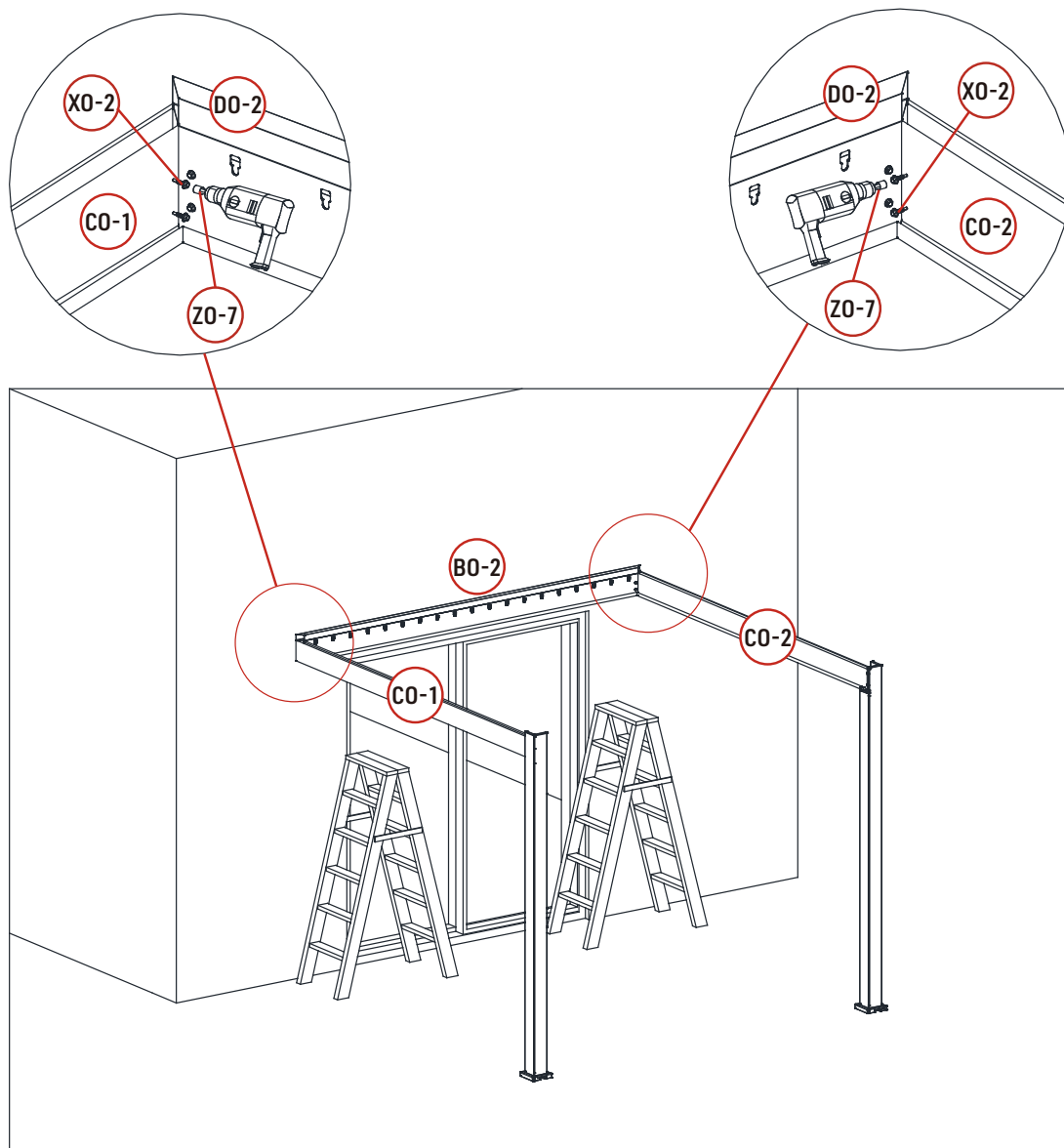

Aggiungete della colla **ZO-8** negli angoli di entrambi i lati del telaio per ottenere la massima tenuta all'acqua come indicato nello schema.

Quindi, per richiudere il telaio, fissate la trave anteriore **BO-1** ai montanti **AO** con le viti **QO**, usando un avvitatore e la punta **ZO-4** oppure la chiave Allen **ZO-3**.

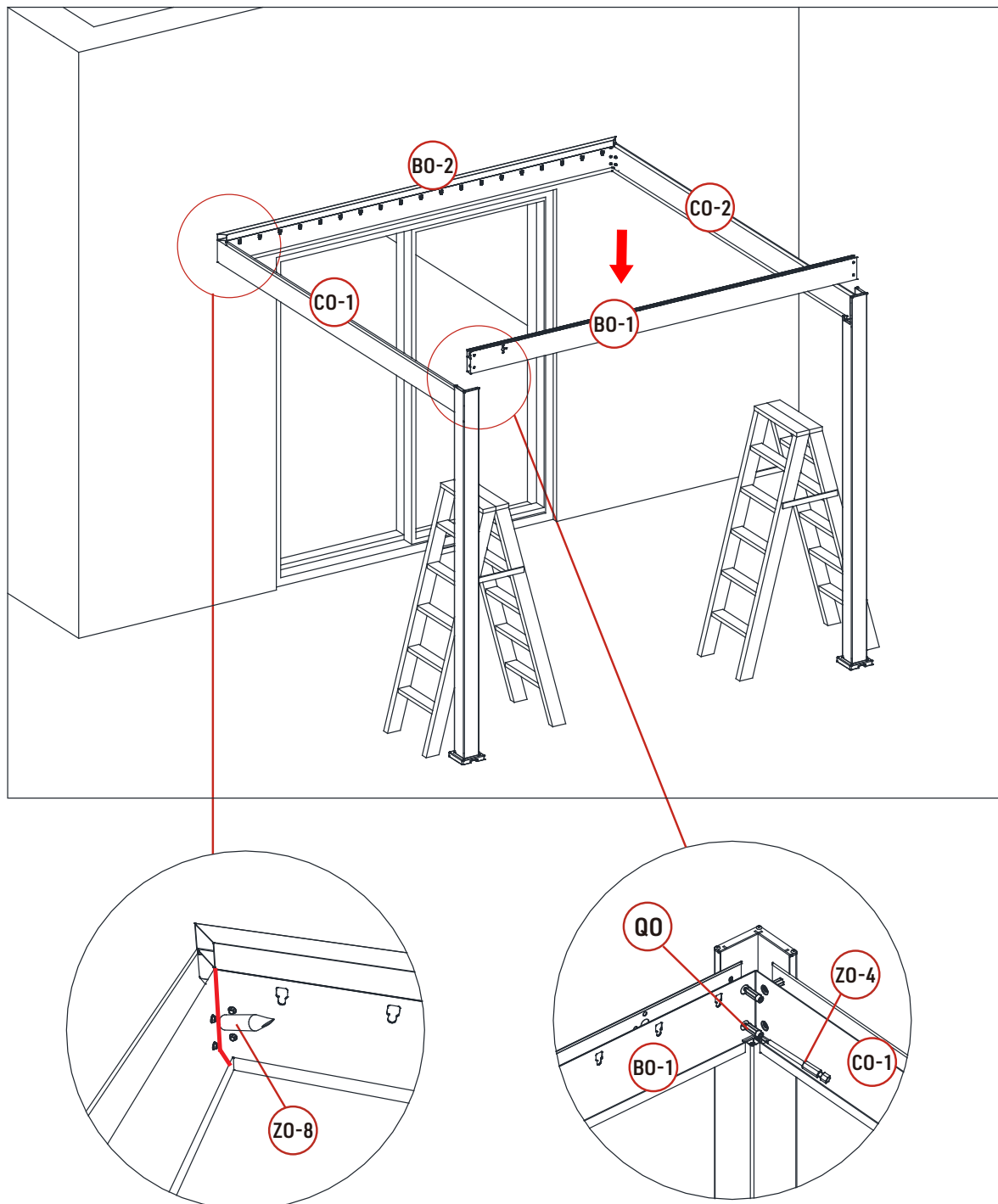

Collegate e avvitate la prima parte della scatola **00** con la gearbox **NO** sulla trave principale **BO-1**, con i 3 bulloni **YO**, utilizzando la chiave Allen **ZO-3** o un avvitatore con una punta **ZO-4**.

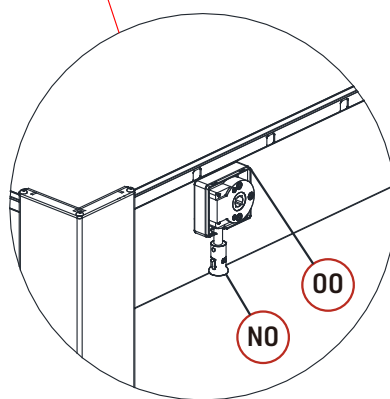
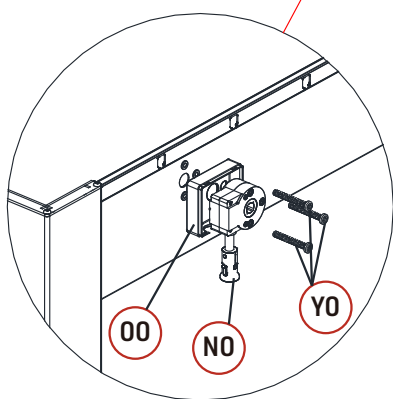
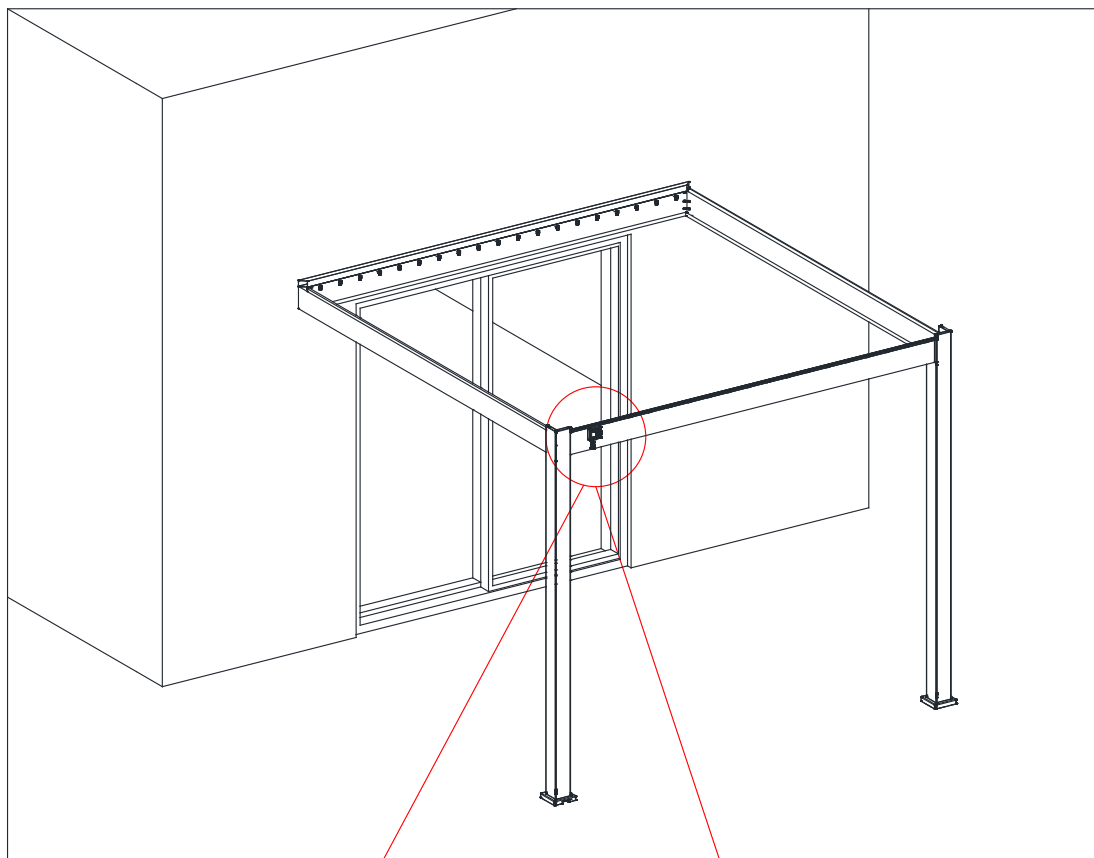

Fissate la pergola a un pavimento duro e piano, utilizzando i tasselli a espansione **TO** grazie a un trapano a percussione con una punta da 12 mm (non fornita).

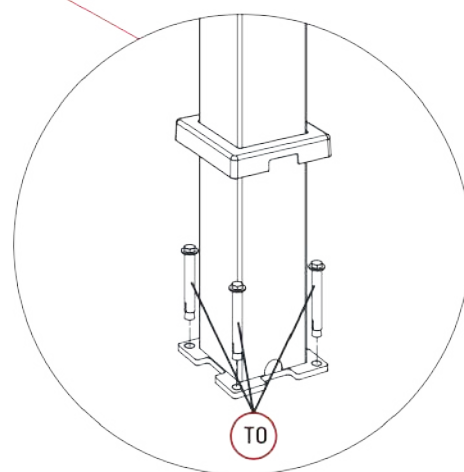
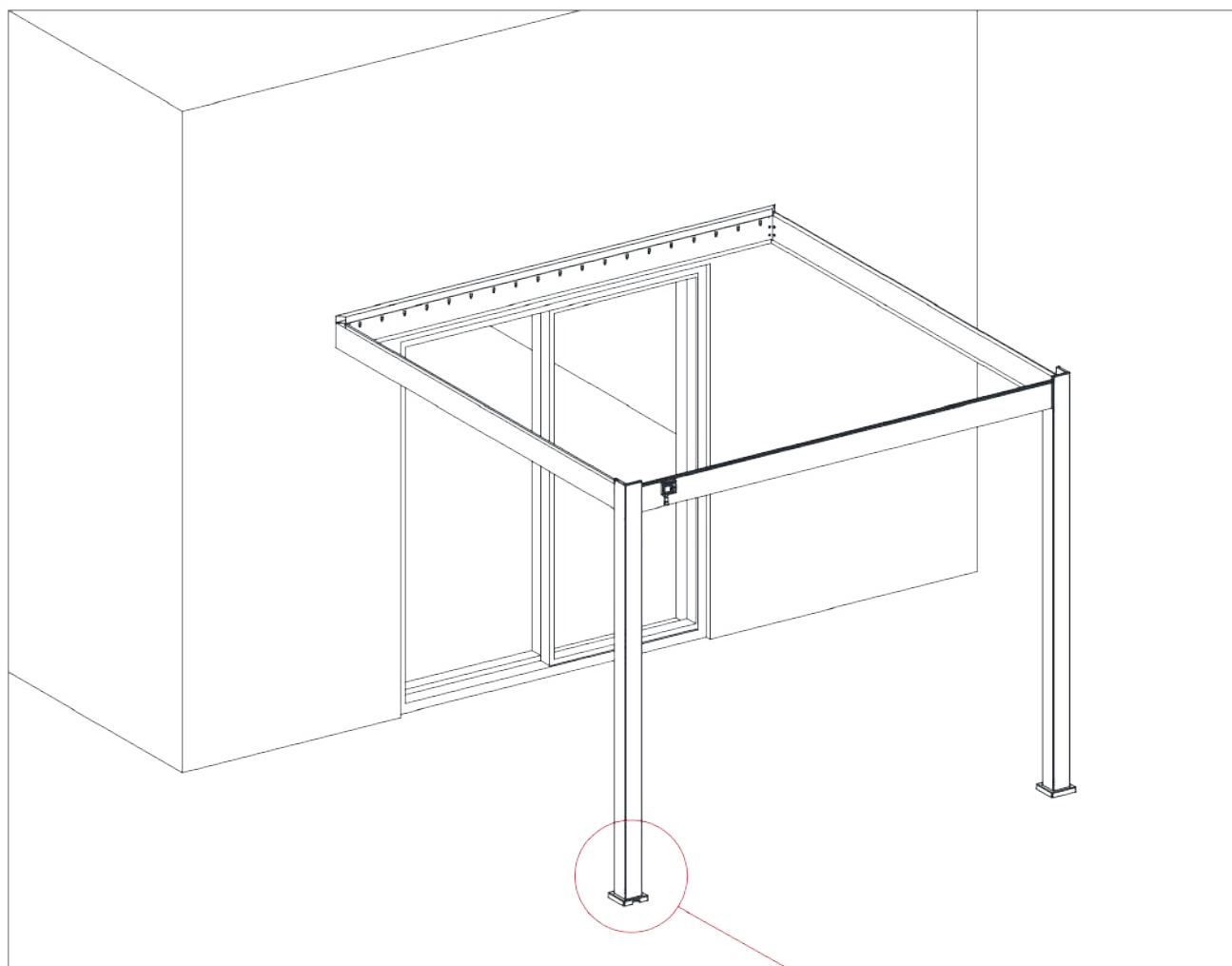

Montate e fissate il perno corrispondente all'insieme delle parti **XO**, **MO** e **UO** nei copri-lamella **LO** e **LO-1**. Assicuratevi che il perno sia installato correttamente nella giusta direzione per la parte **LO** e per la parte **LO-1**, come indicato nello schema.

Utilizzate l'avvitatore e la punta **ZO-2** per inserire il bullone **XO** nel dado **UO**.

Per evitare lesioni e rendere l'operazione non troppo difficile, si consiglia di tenere il dado con la chiave **ZO-5** durante questa manipolazione.

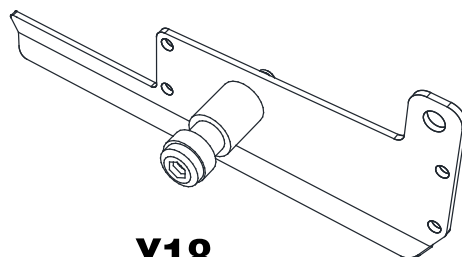
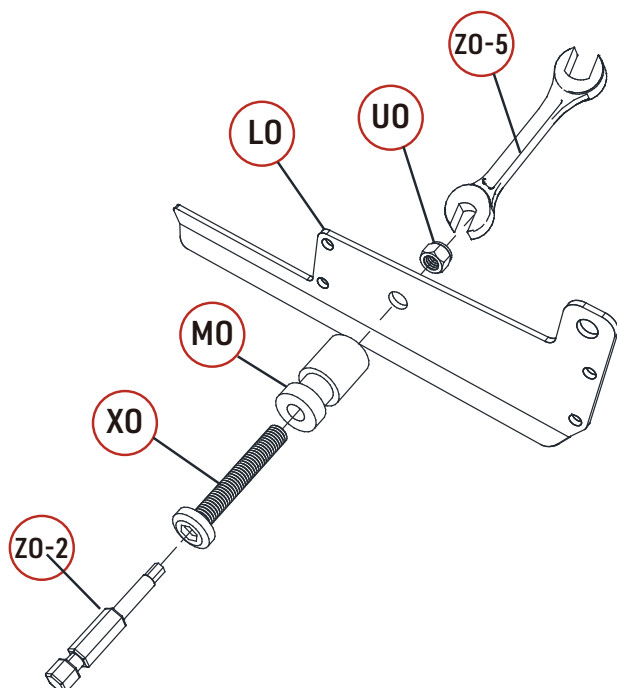
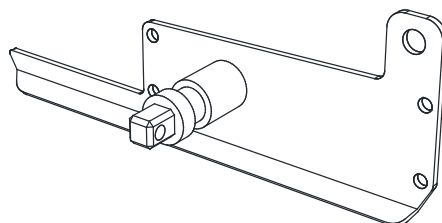

X18

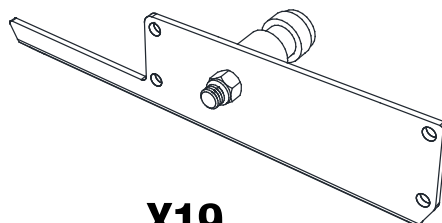
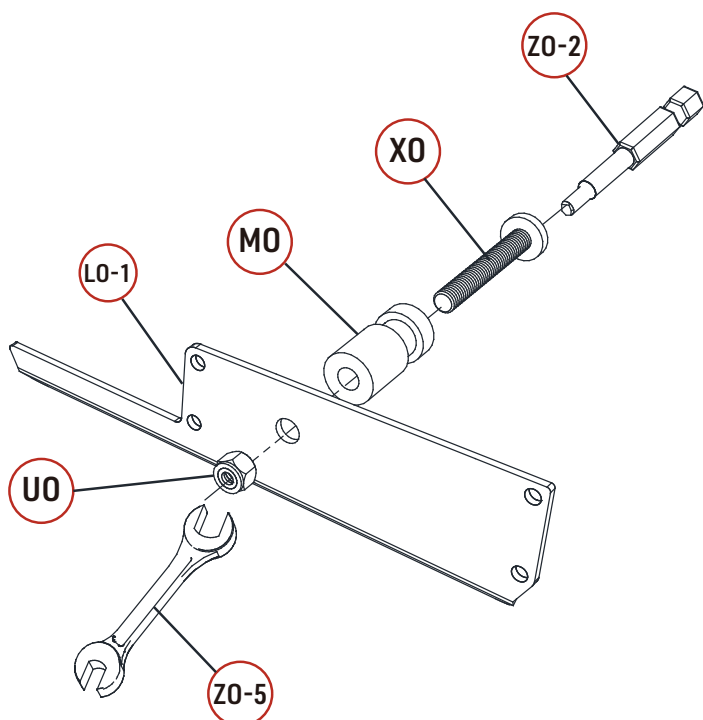

X19

Posizionate la lamella principale **GO** nella direzione corretta, come indicato nello schema, quindi fissate il copri-lamella principale **KO** a destra della lamella e **LO-1** a sinistra, con le viti **WO** grazie all'avvitatore e la punta T20 **ZO-6**.

X1

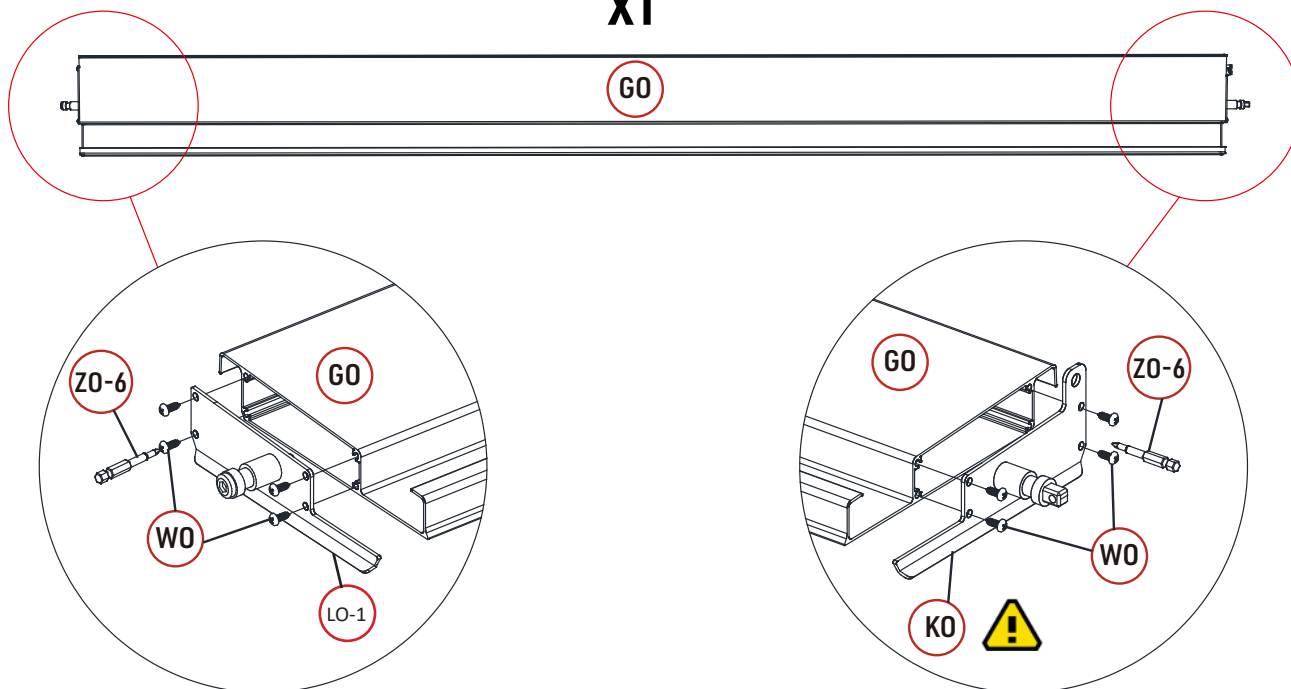

Ripetete la stessa operazione con le altre lamelle **GO**, fissando i copri-lamella **LO-1** a sinistra e **LO** a destra.

X18

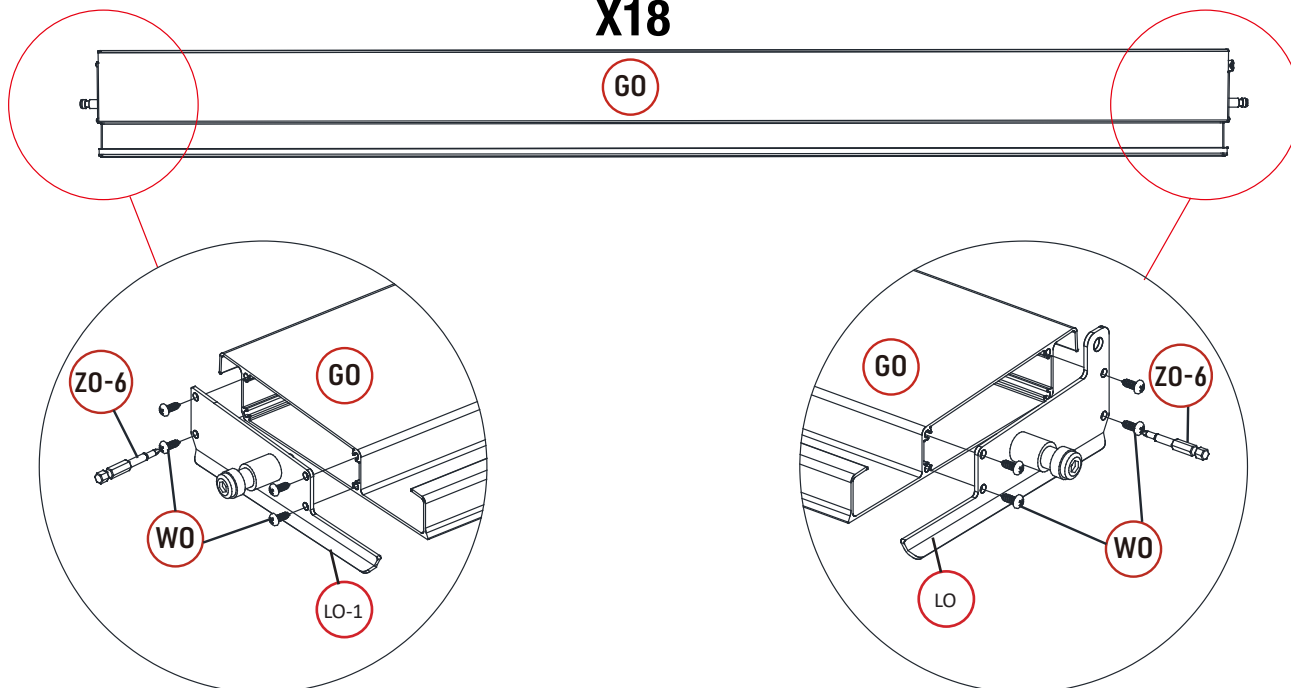

Installate quindi la lamella principale nella seconda posizione prevista sulla pergola, partendo dal lato della manovella per formare il tetto.

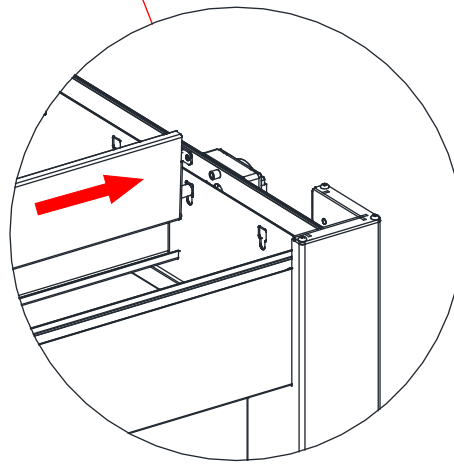
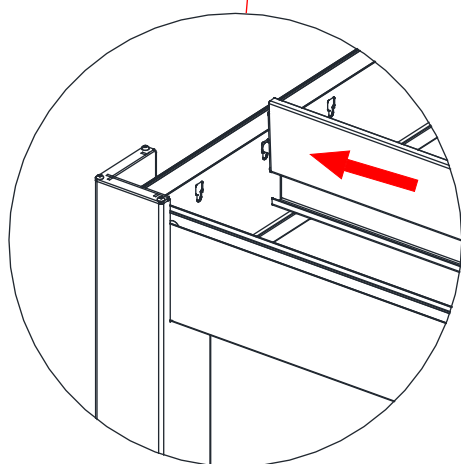
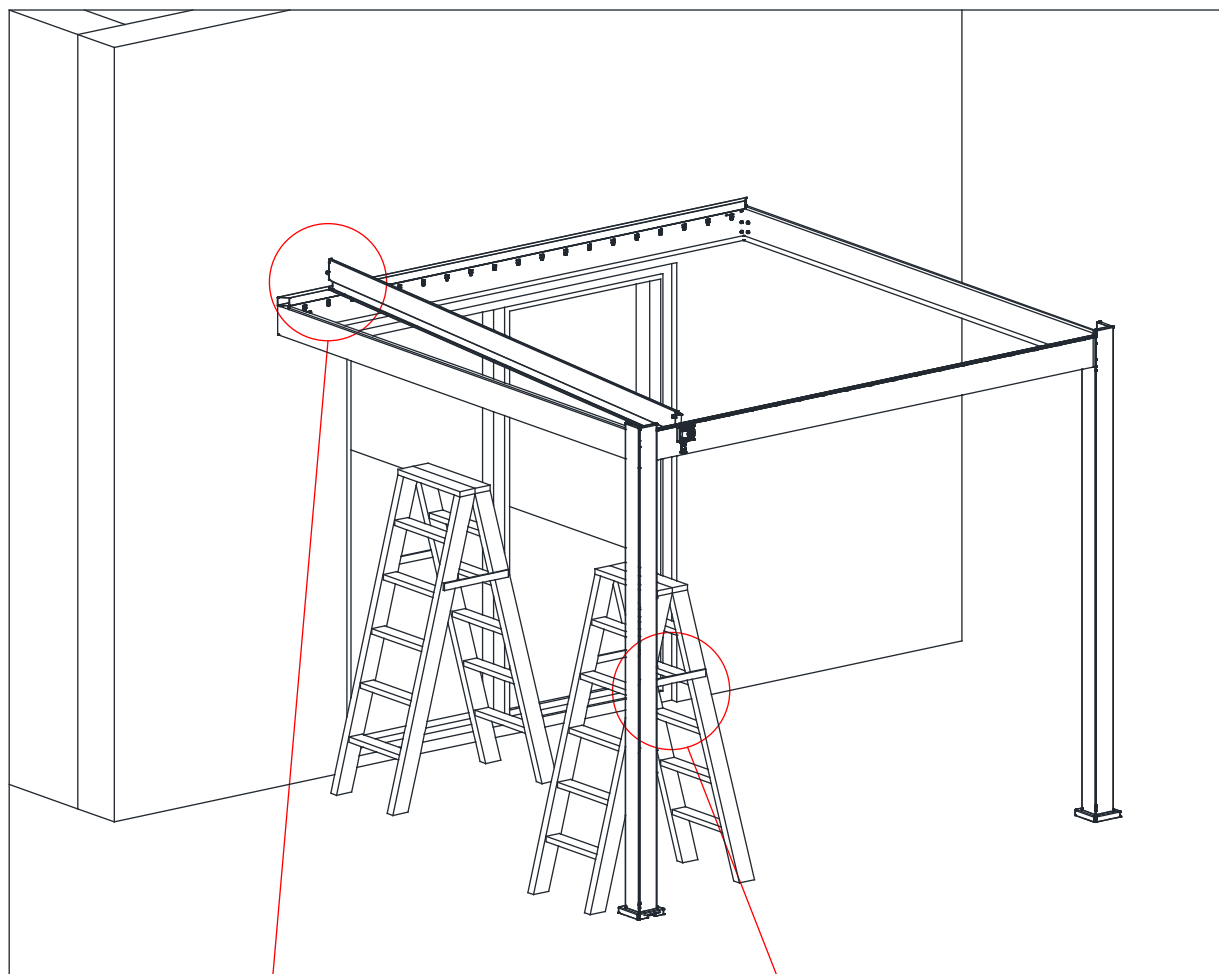

Inserite il cilindro **PO** nella gearbox e attraverso la trave, quindi spingete finché non si incastra con il perno della lamella principale.

Assicuratevi che il meccanismo manuale funzioni correttamente ruotando la lamella a destra e poi a sinistra con la manovella **HO**.

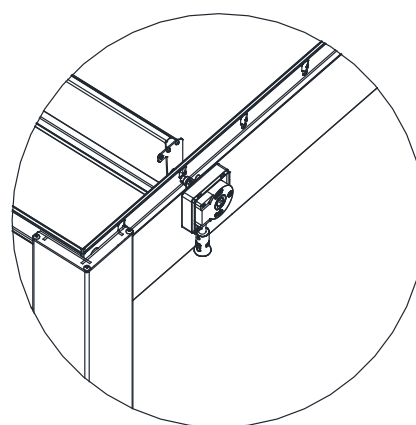
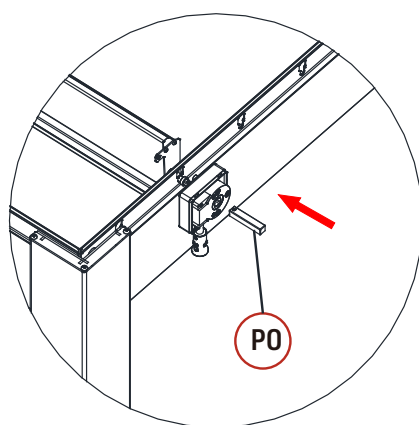
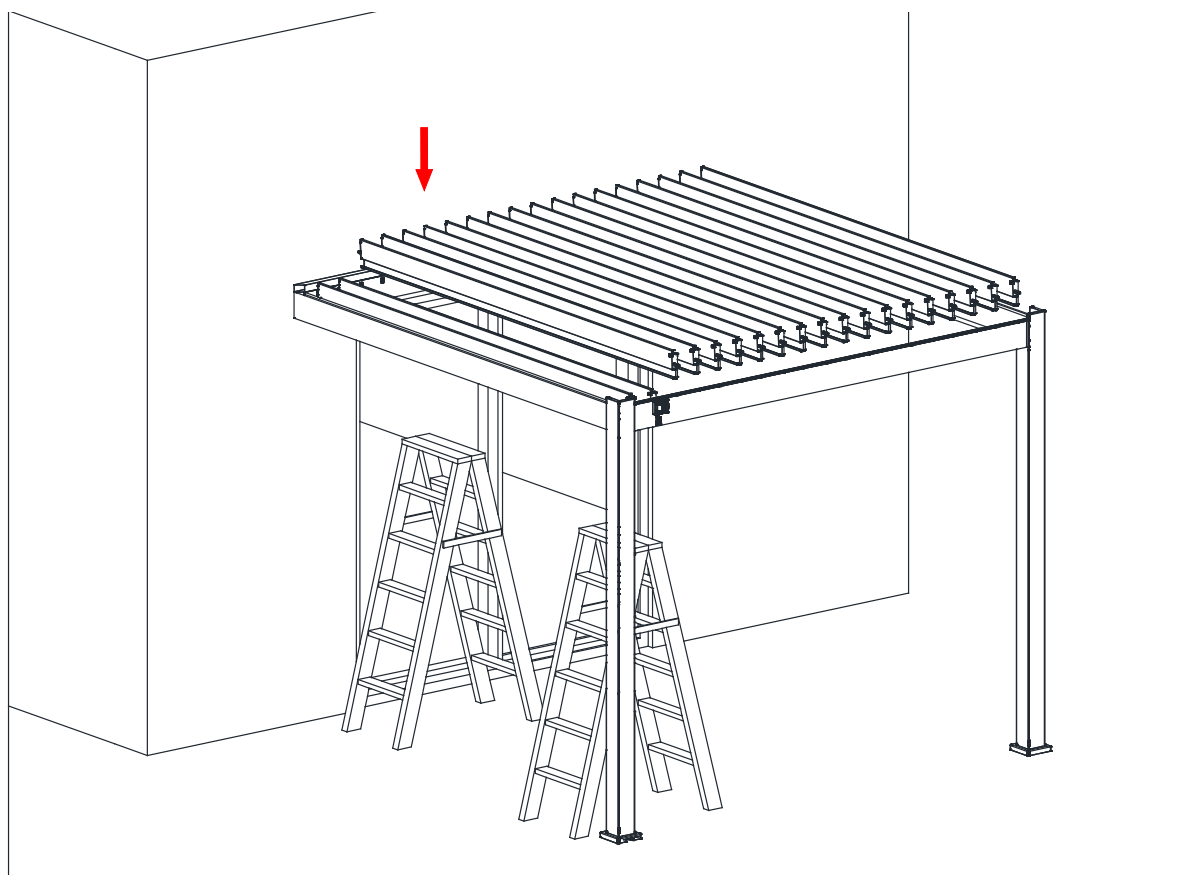

Mettete la lamella in posizione verticale, per installare le altre lamelle una dopo l'altra.

Fissate la barra di giunzione **FO** a tutte le lamelle con le rondelle **VO** e i dadi **UO**, utilizzando un avvitatore e la punta T20 **ZO-6** e la chiave **ZO-5** per tenere il dado.

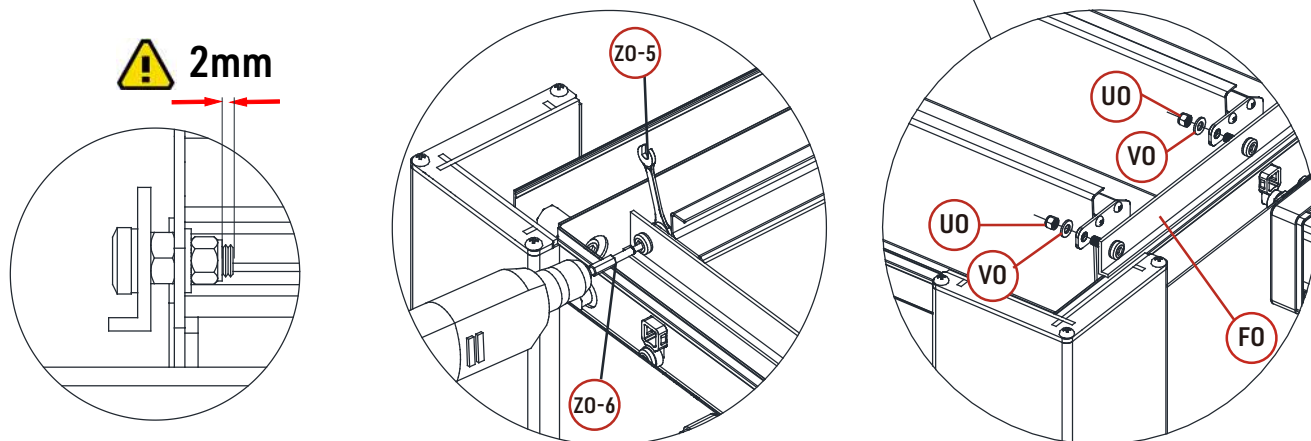
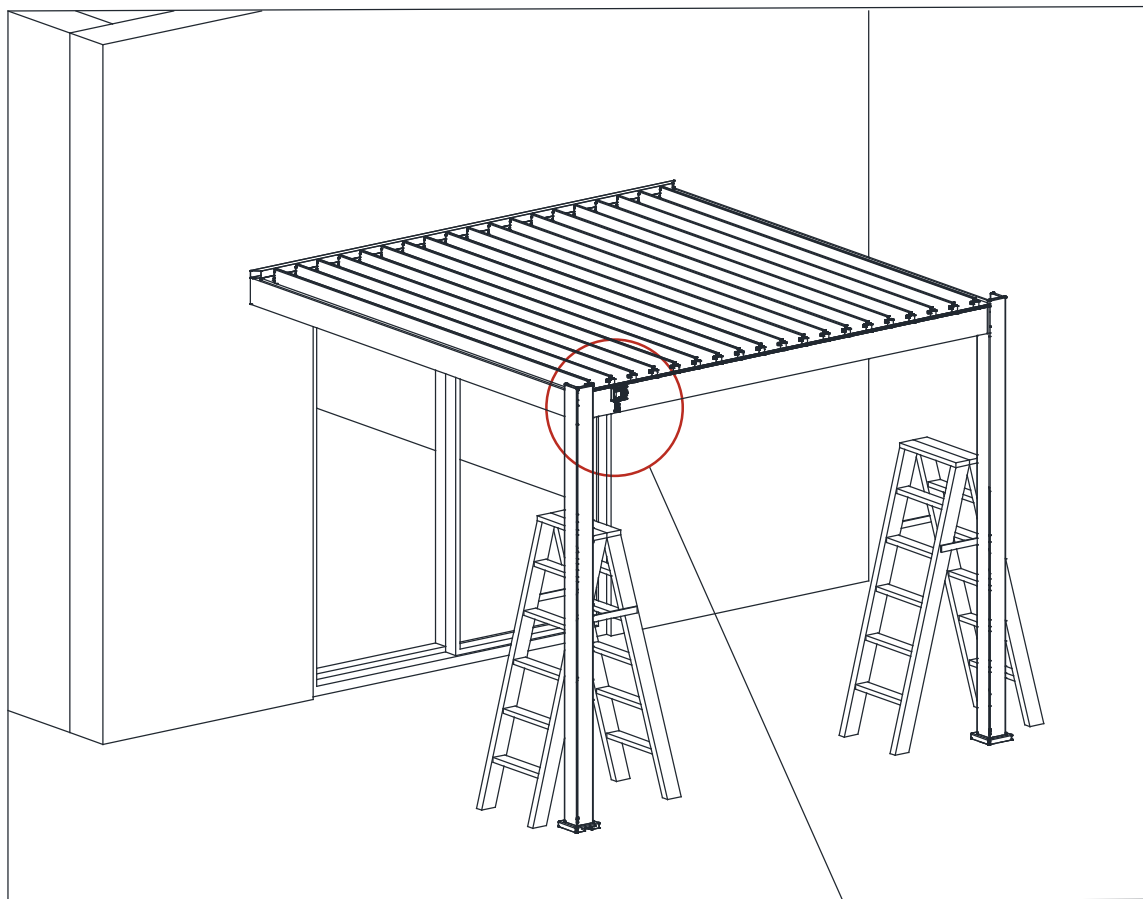

Installate e incastrate le estensioni **DO-1**, **DO-3** e **DO-4** sulle travi come indicato nello schema. Inserite quindi i cunei a mezzaluna **SO**. L'apertura a mezzaluna deve trovarsi sulla parte inferiore del cuneo.

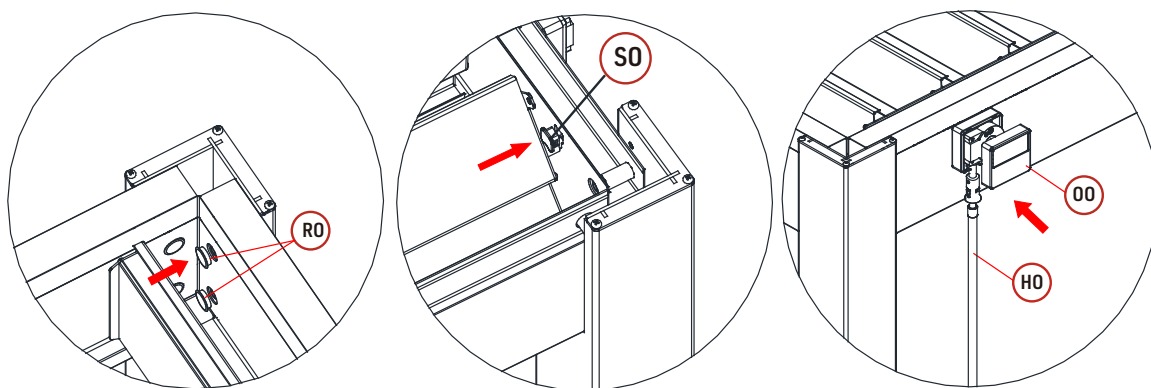
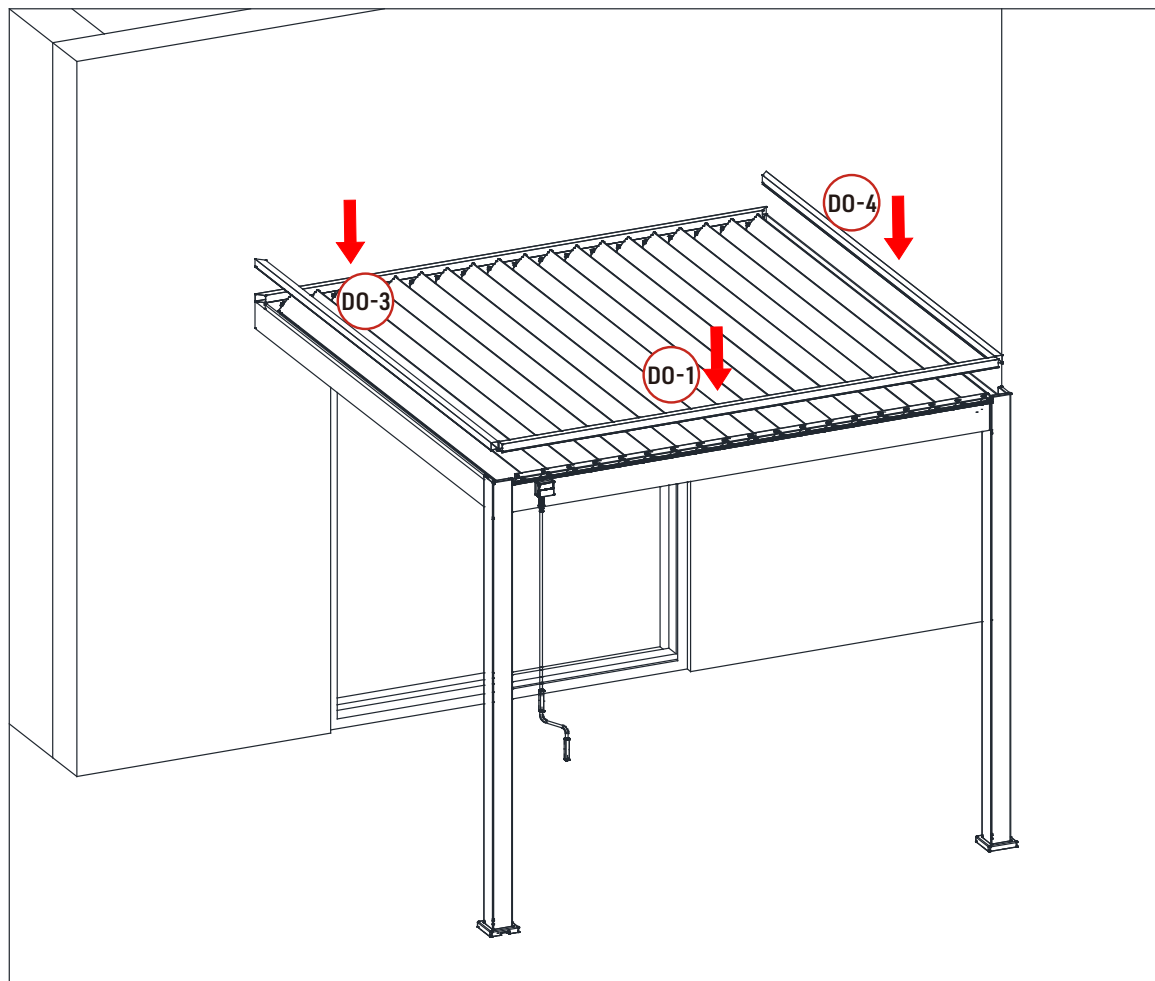

Inserite i tappi **RO** per coprire i fori negli angoli del telaio. Incastrate quindi la seconda parte della scatola **OO** per chiuderla e completate l'installazione.