

Garage à vélos/ Bikebox

weka

Référence: 70212210600
70212210700

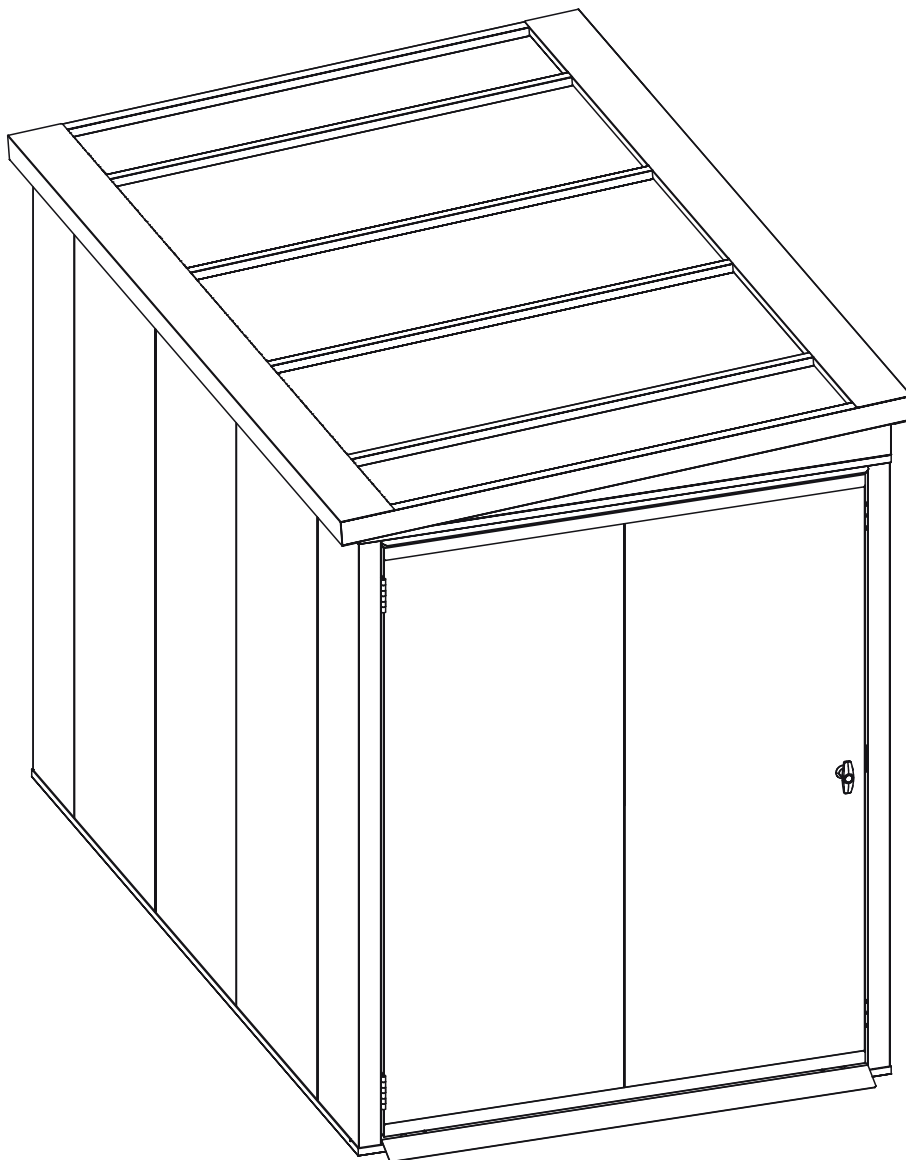

Instructions de montage

www.weka-holzbau.com

weka Holzbau GmbH
Postfach 20 02 04
D-17013 Neubrandenburg

Vous pouvez nous joindre :
Du lundi au vendredi, de 8h30 à 18h00
+49 (0)395/42908-0

Consignes de sécurité/ safety instructions

Les remarques s'appliquent aux articles suivants/The information applies to the following items: 70212210600, 70212210700

1. Équipe de montage/Assembly Team

FR: Le montage doit toujours être effectué par deux personnes.

EN: Assembly must always be carried out by two people.

2. Équipement de protection et support Protective Equipment & Surface Protection

FR : Portez des gants de travail lors du montage. Utilisez un support approprié pour éviter les rayures.

Verwenden Sie eine geeignete Unterlage, um Kratzer zu vermeiden.

EN: Wear work gloves during assembly.

Use a suitable surface protector to avoid scratches.

3. Pièces endommagées/Damaged Parts

FRDE : N'installez pas de composants endommagés.

Les dommages constatés doivent nous être signalés à l'aide de photos explicites. Les pièces déjà installées sont considérées comme acceptées.

EN: Do not install any damaged components.

Report all identified damage to us with meaningful photos.

Parts that have already been installed are considered accepted.

4. Assemblages vissés/ Screw Connections

FR : Ne serrez tous les raccords vissés qu'une fois le montage terminé.

EN: Tighten all screw connections only after the assembly has been fully completed.

5. Stabilité et conditions météorologiques / Stability & Weather Conditions

FR: Assurez-vous que l'ancrage au sol résiste aux tempêtes.

Ne placez pas le produit dans un endroit exposé au vent.

EN: Ensure the product is securely anchored to the ground to withstand strong winds.

Do not assemble the product in windy conditions.

6. Sécurité des enfants et arêtes vives / Child Safety and Sharp Edges

FR Pendant le montage, gardez les petites pièces et les matériaux d'emballage hors de portée des enfants.

Les composants peuvent présenter des arêtes vives ou des parties saillantes.

Veillez à respecter cette consigne lors du montage et de l'utilisation quotidienne.

EN: Keep small parts and packaging materials away from children during assembly.

Components may have sharp edges or protruding parts.

Pay attention to this during assembly and during everyday use

7. Sécurité à haute température

FR : En été, la température à l'intérieur du véhicule peut atteindre des niveaux très élevés.

EN: During summer, very high temperatures may occur inside the house.

8. Couvercles

FR : N'utilisez pas de couvercles ou de housses pour le produit.

EN: Do not use covers or tarpaulins on the product.

9. Sol

FR: Le produit ne doit être monté que sur un support adapté, solide et plat.

EN: The product may only be assembled on a suitable, solid, and level surface.

10. Transport/ Transport

FR: Le produit ne peut pas être transporté assemblé.

Il doit être assemblé sur son lieu d'installation définitif afin d'éviter tout dommage lié au transport.

EN: The product is not suitable for transport in assembled condition.

It must be assembled at its final installation location to avoid transport damage.

11. Remarque concernant la garantie/ Warranty Notice

FR: Attention : toute modification ou altération du produit

entraîne l'annulation de la garantie.

EN: Please note – Any changes or modifications to the product will void the warranty.

Entretien et maintenance / Care and Maintenance

1. Produits chimiques et nettoyage Chemicals & Cleaning

FR : Ne stockez pas de produits chimiques agressifs tels que le chlore ou le sel de déneigement dans ou sur le produit.

N'utilisez pas de produits nettoyants abrasifs. Nettoyez la crème solaire et autres crèmes à l'eau et au savon !

EN: Do not store aggressive chemicals such as chlorine or road salt in or near the product.

Do not use abrasive cleaning agents. Remove sunscreen and other creams with soap and water!

2. Neige et charge de neige Snow & Snow load

FR : Déblayez régulièrement la neige du toit afin de ne pas dépasser la limite maximale de charge de neige et d'éviter tout risque d'effondrement.

EN: Regularly remove snow from the roof to avoid exceeding the maximum snow load limit and prevent the risk of collapse.

3. serrure de porte/ Lock

DE: Huilez la serrure une fois par an !

EN: Oil the lock annually!

4. assemblages vissés/ Screw Connections

FR : Contrôlez régulièrement les raccords vissés !

5. EN: Check screw connections regularly!



$a = b$

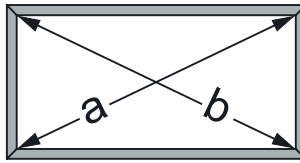

A

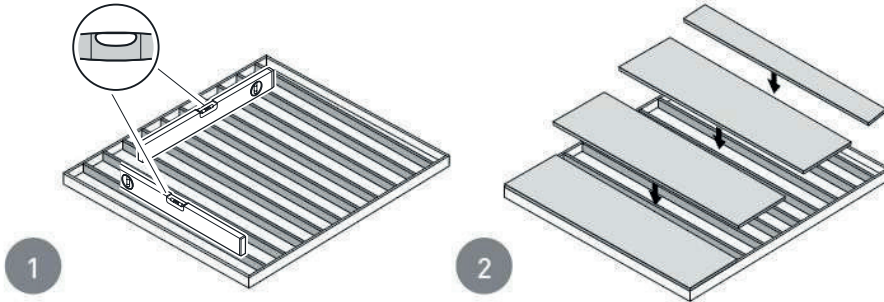

B

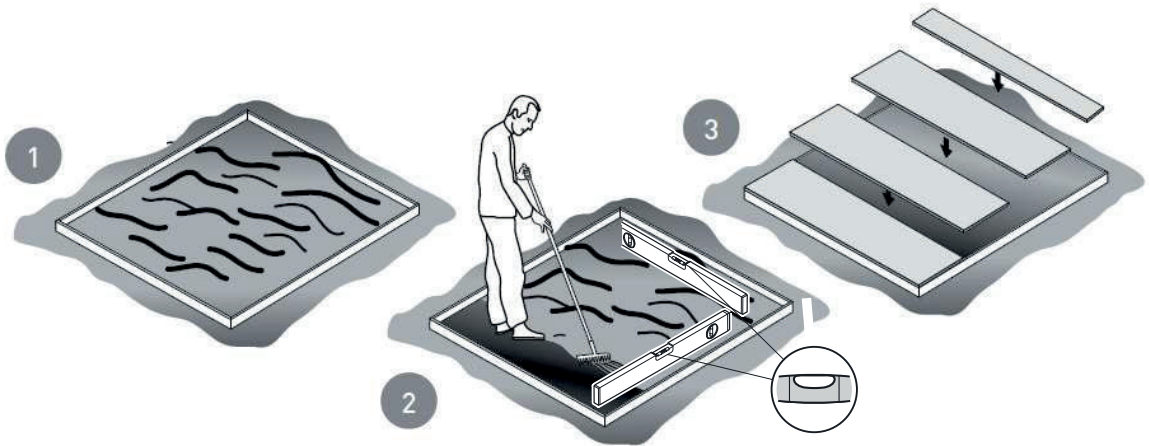

C

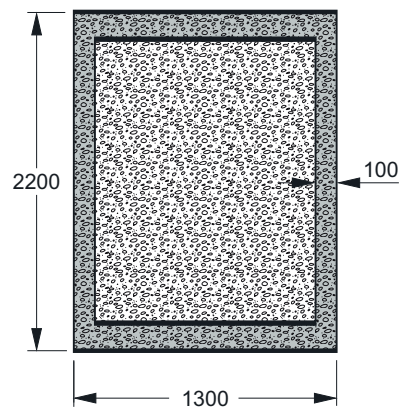
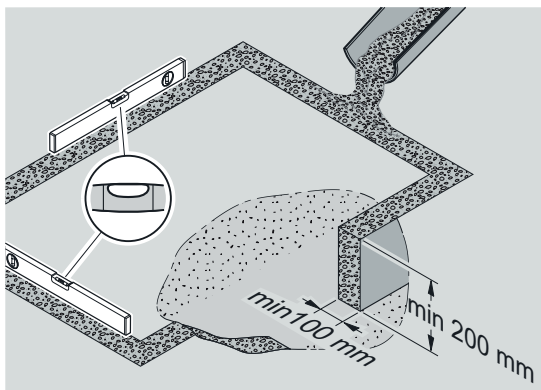

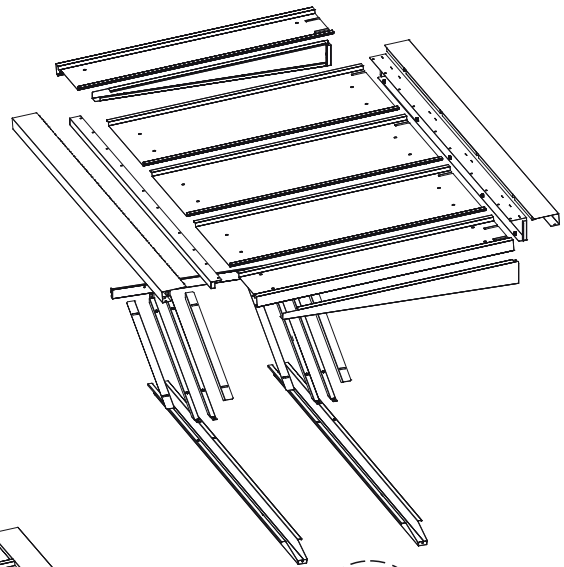
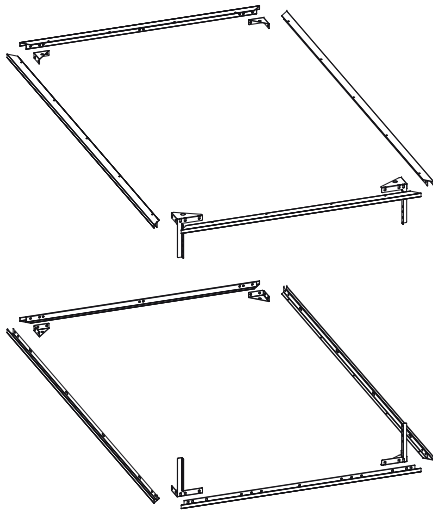
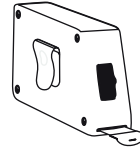
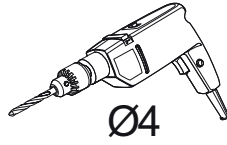
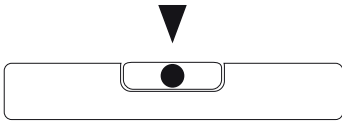
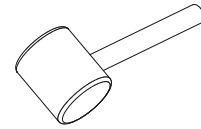
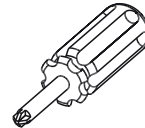
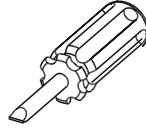
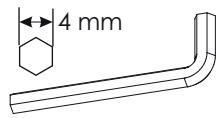
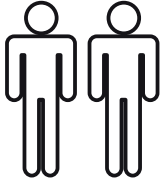

A.1

C.1

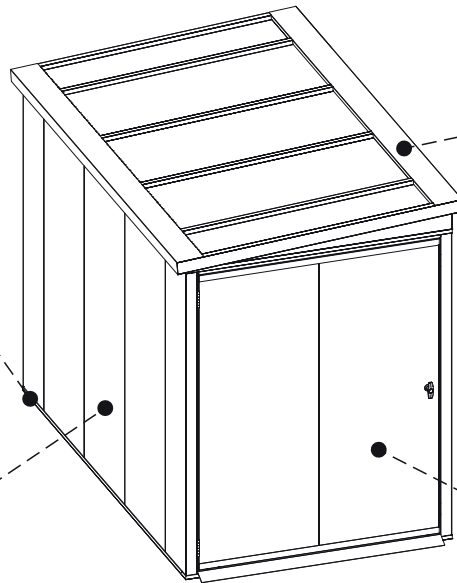

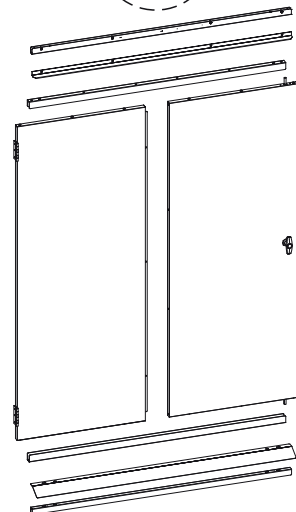
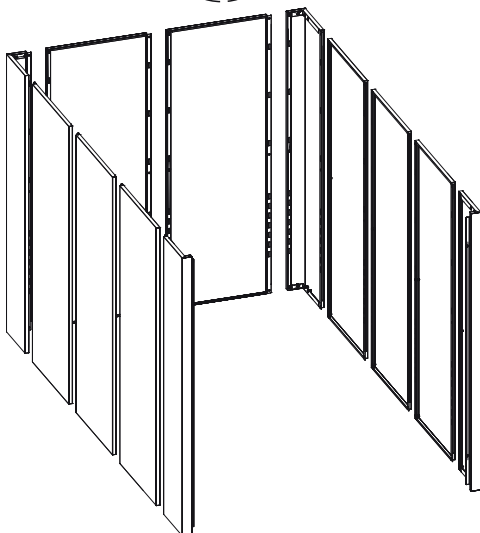

B.1

D.1

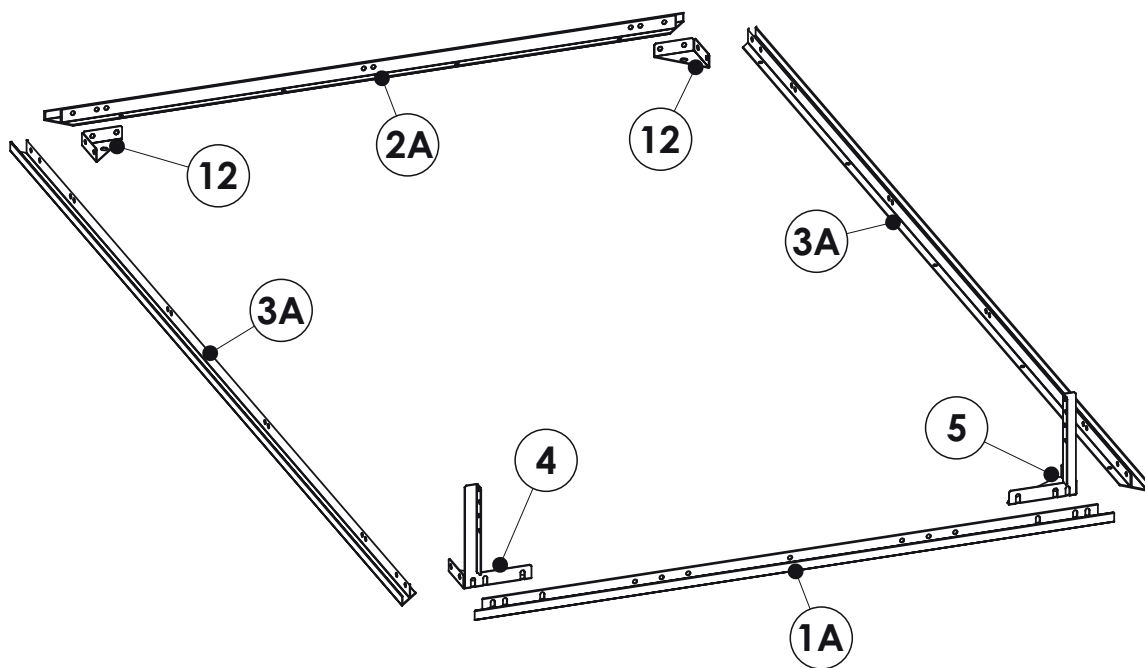
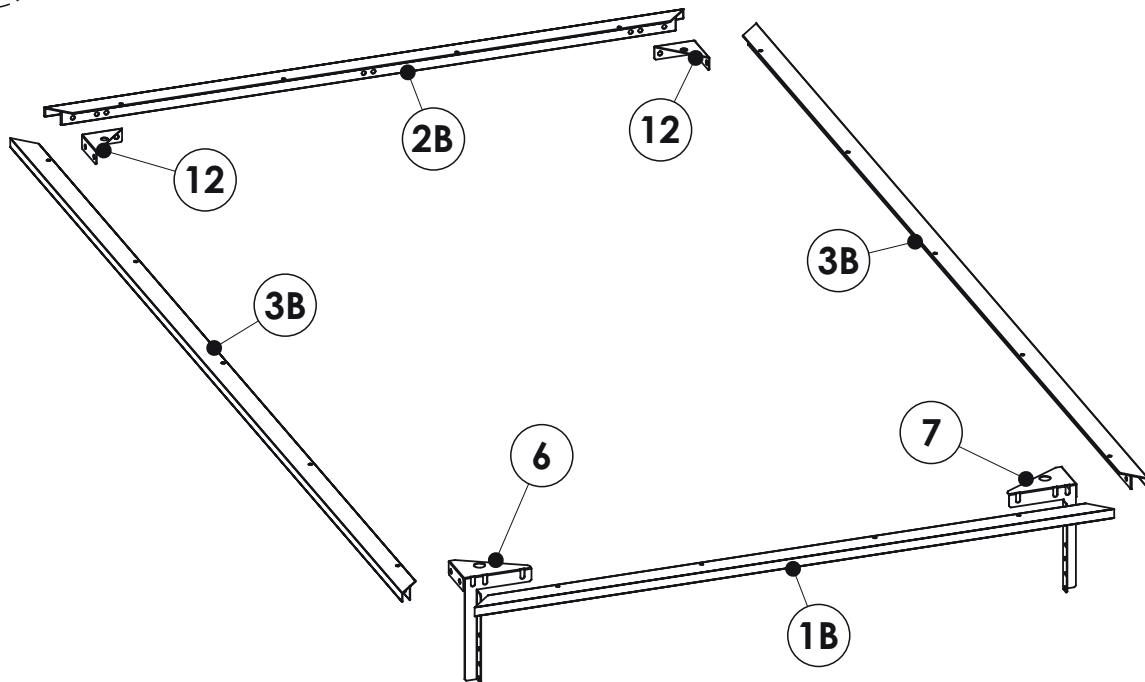

A1

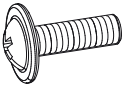

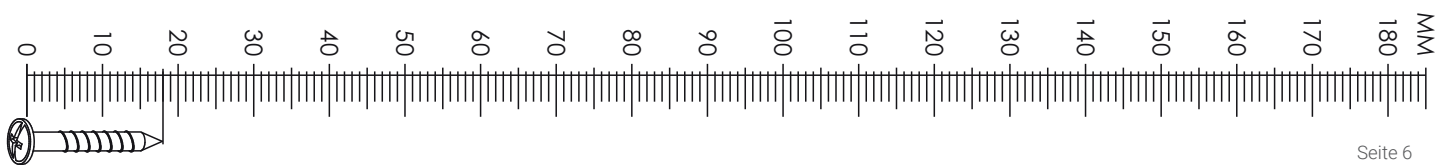

S1	x64	S2	x8
			
M6 x 16 mm		M4 x 12 mm	

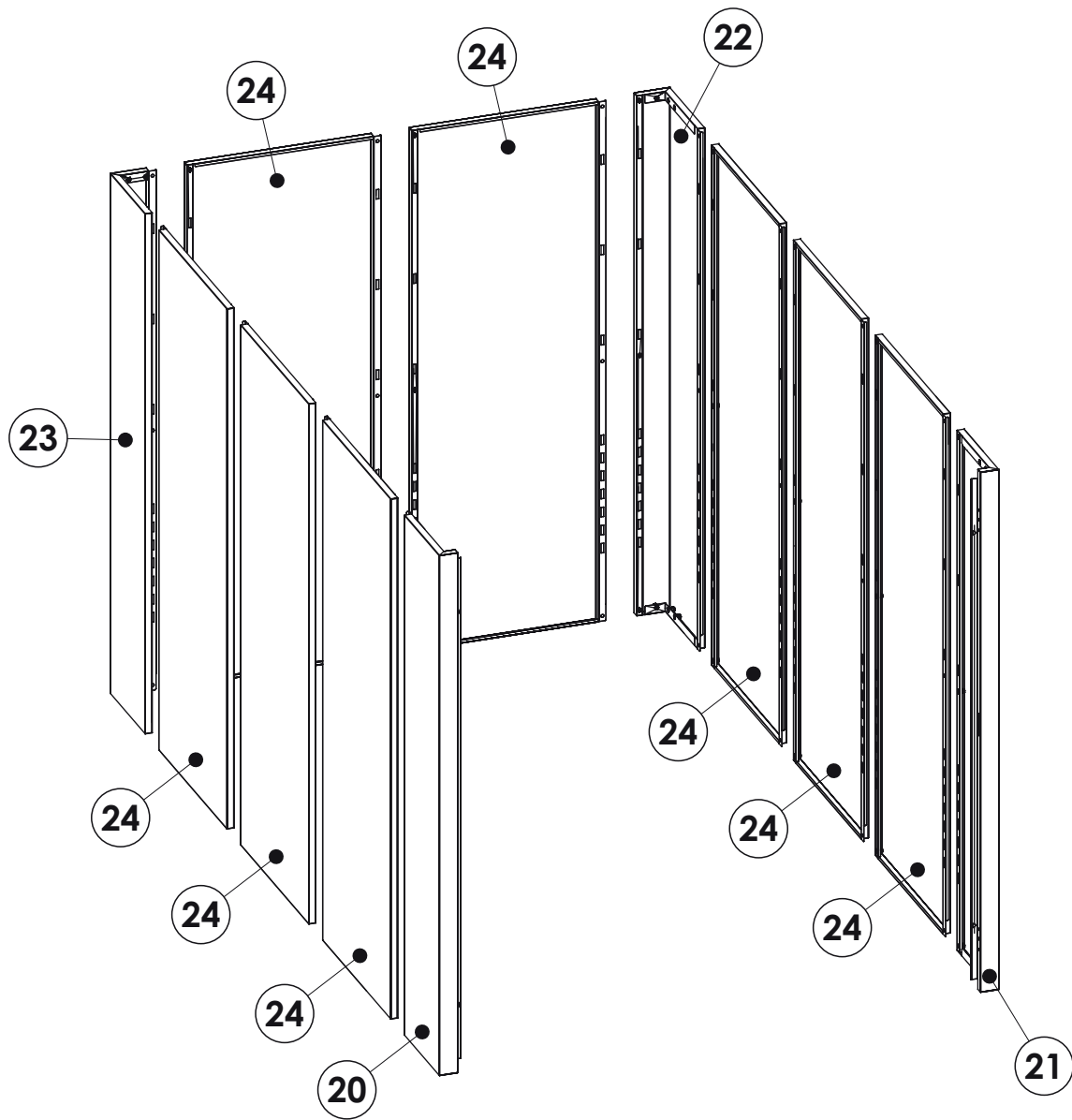
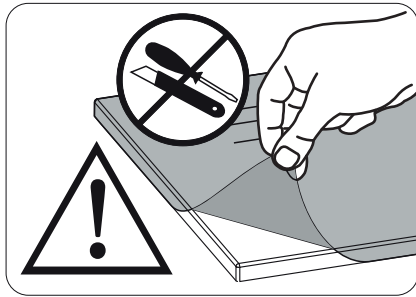

B1

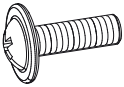

S1  M6 x 16 mm	S2  M4 x 12 mm	S5  x2
--	--	--



C1

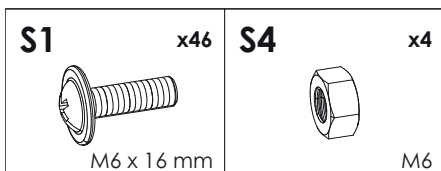
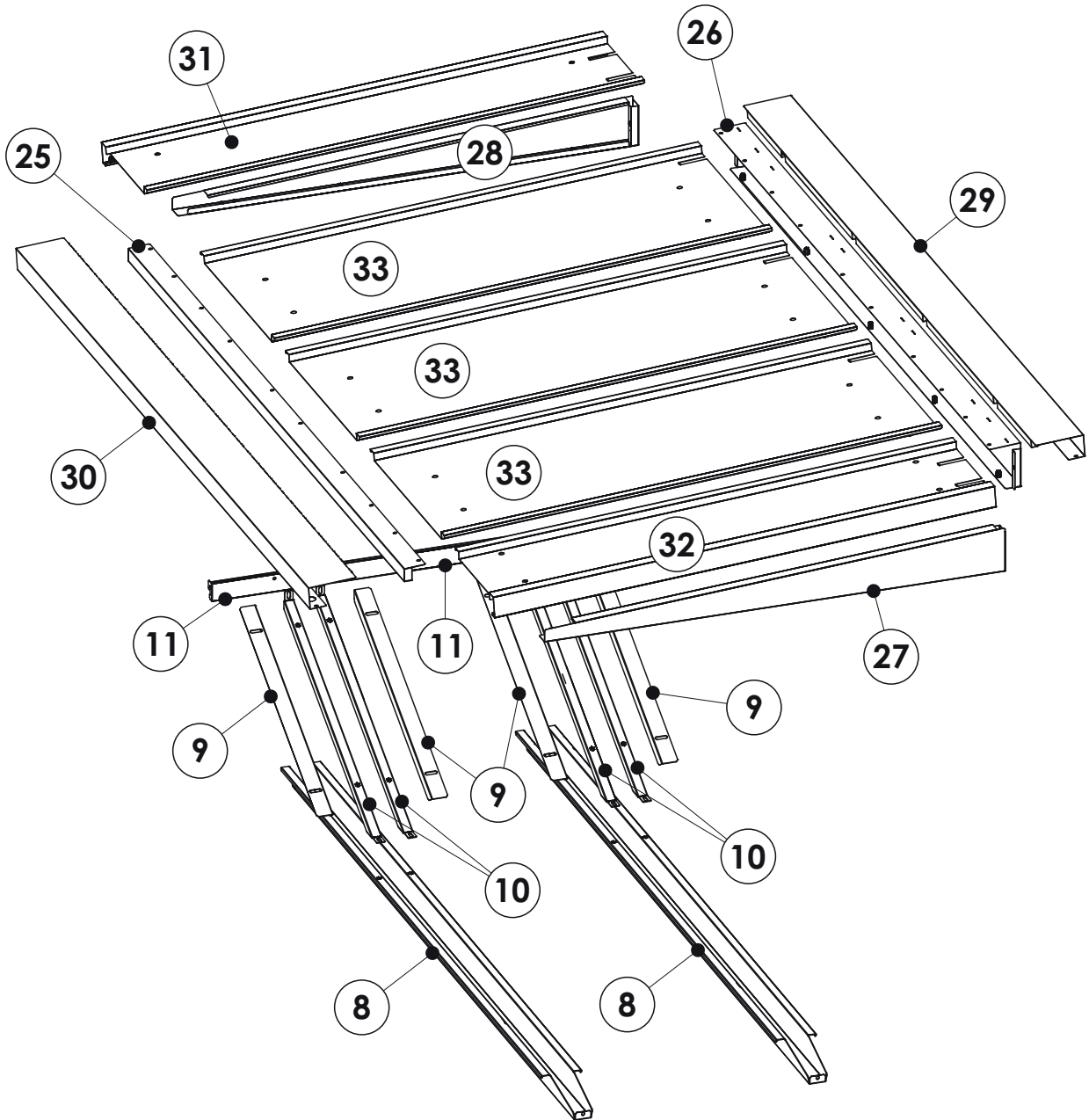
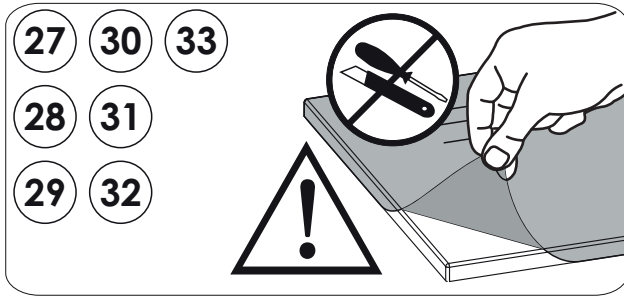

D1

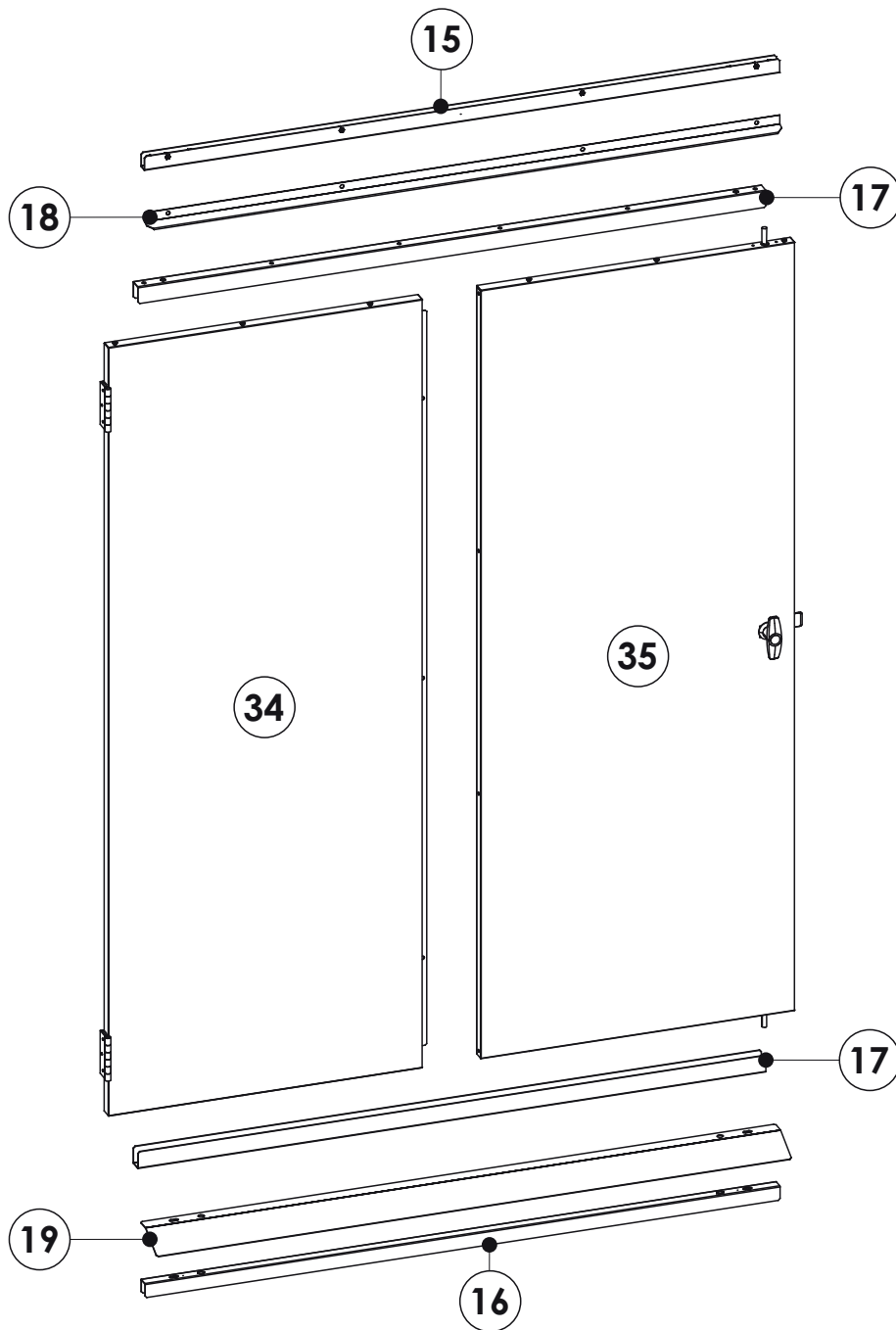

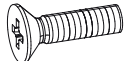
S2	x19	S3	x2
			
M4 x 12 mm		M6 x 16 mm	

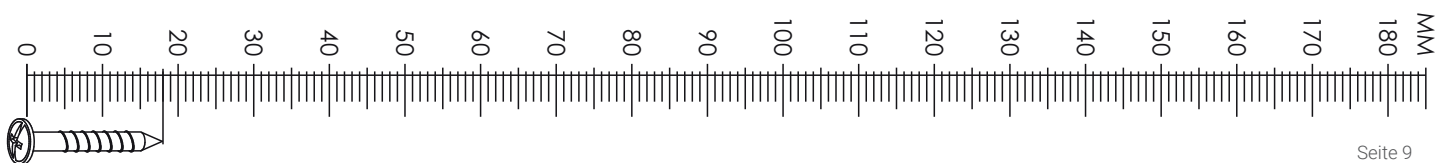

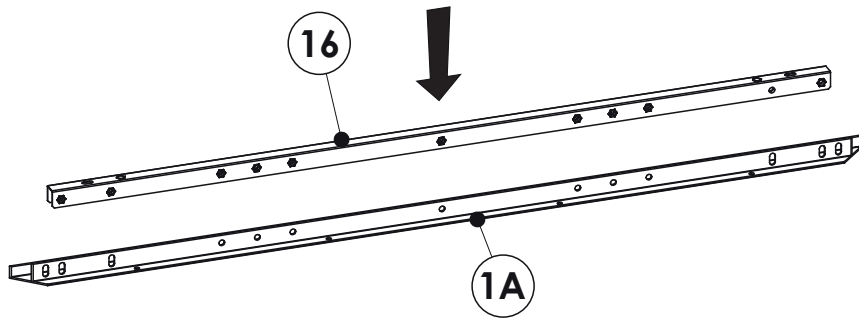

1

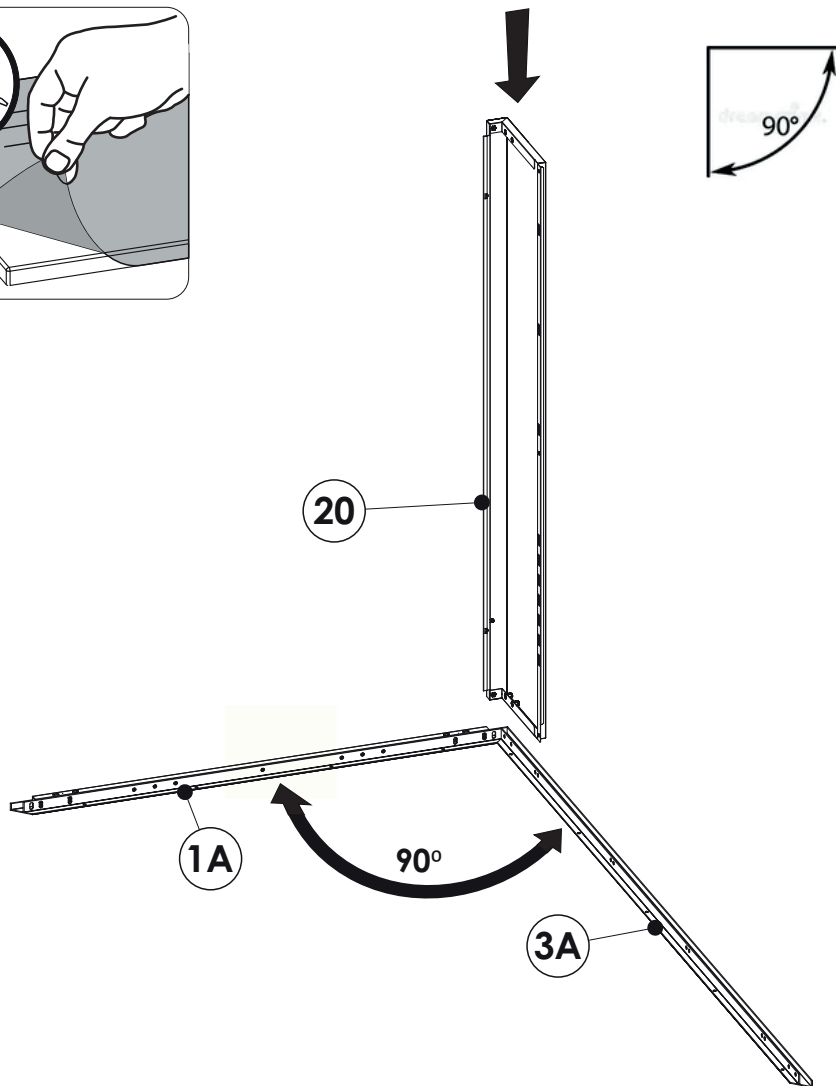
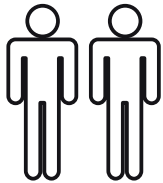
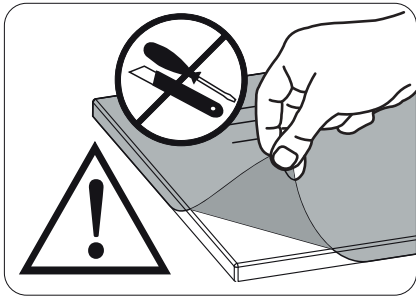

2

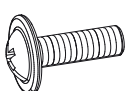

3

S1	x5
	
M6 x 16 mm	
S2	x1
	
M4 x 12 mm	

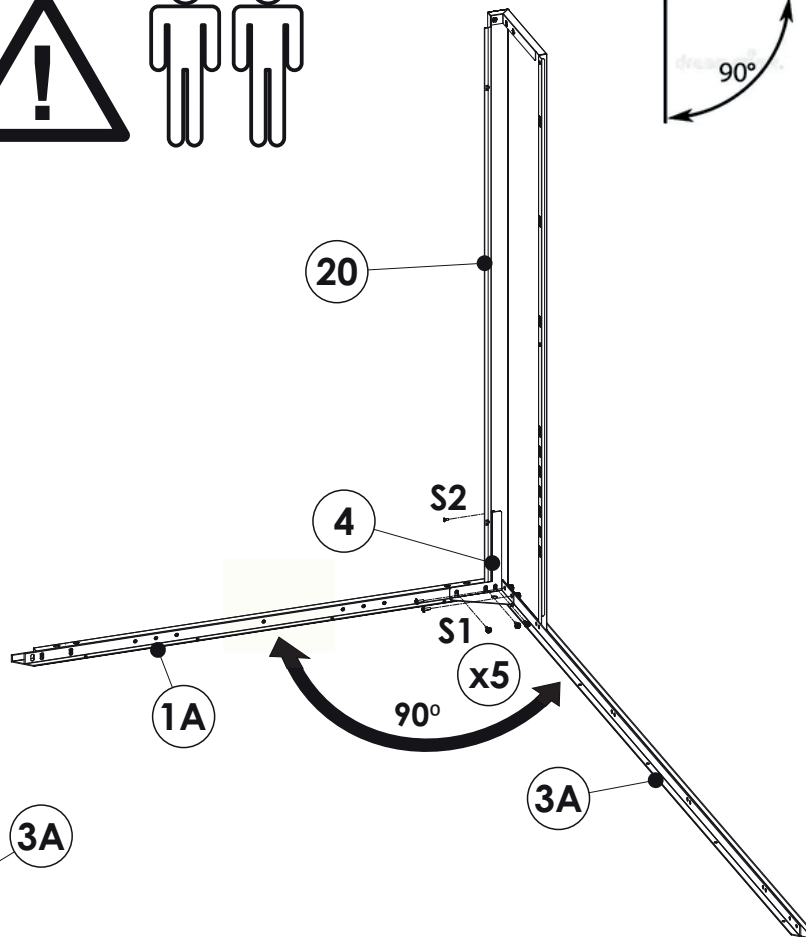
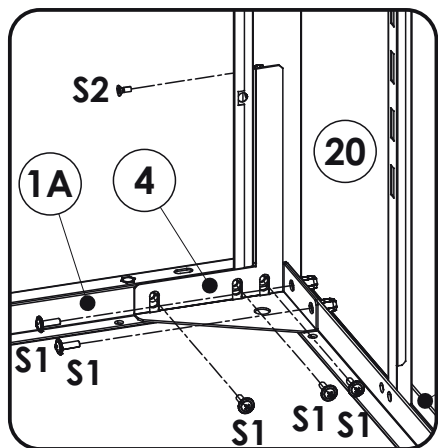
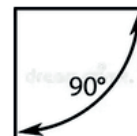
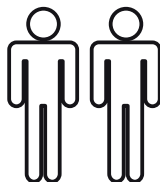

4

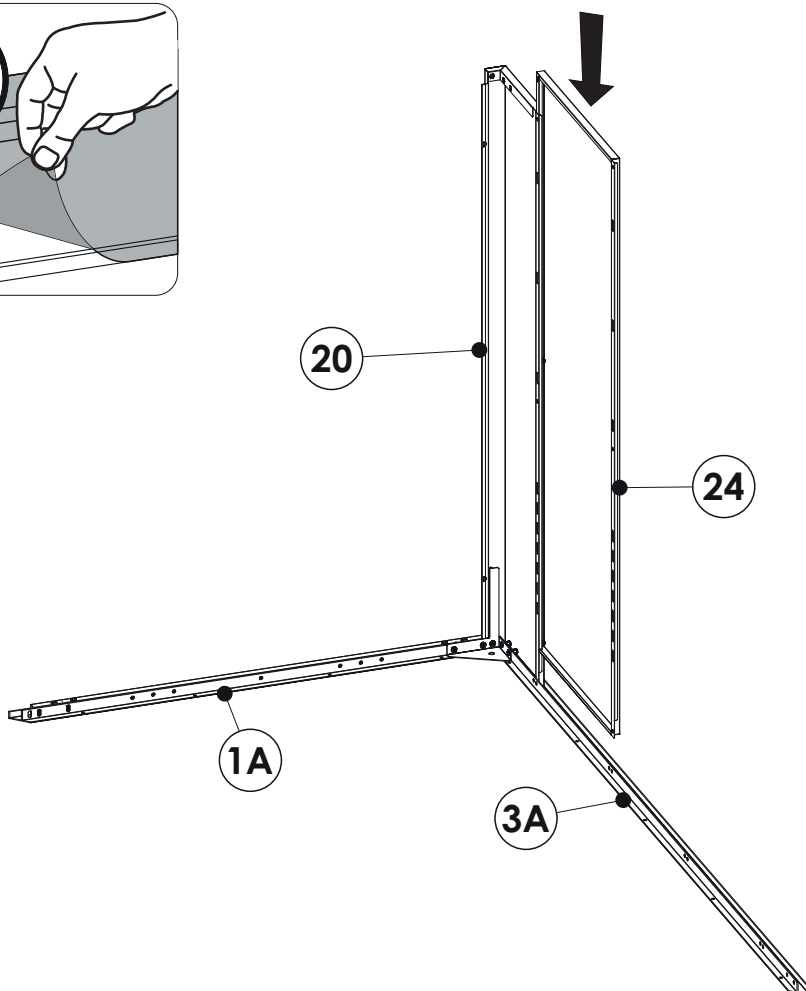
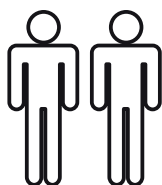
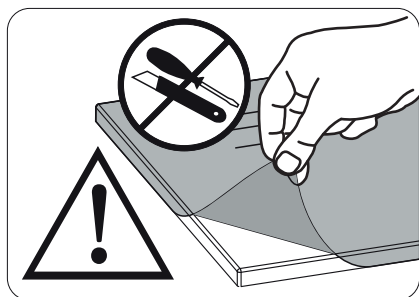

5

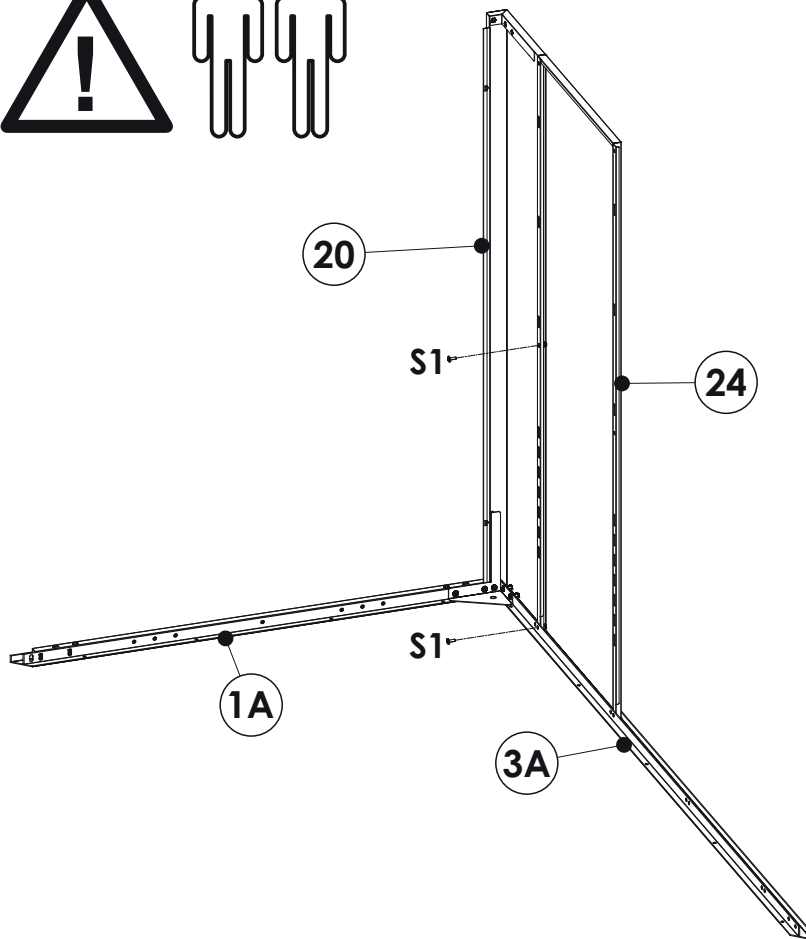
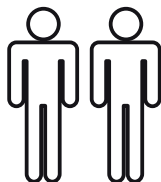
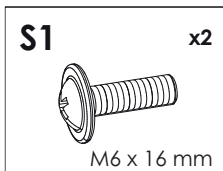

6

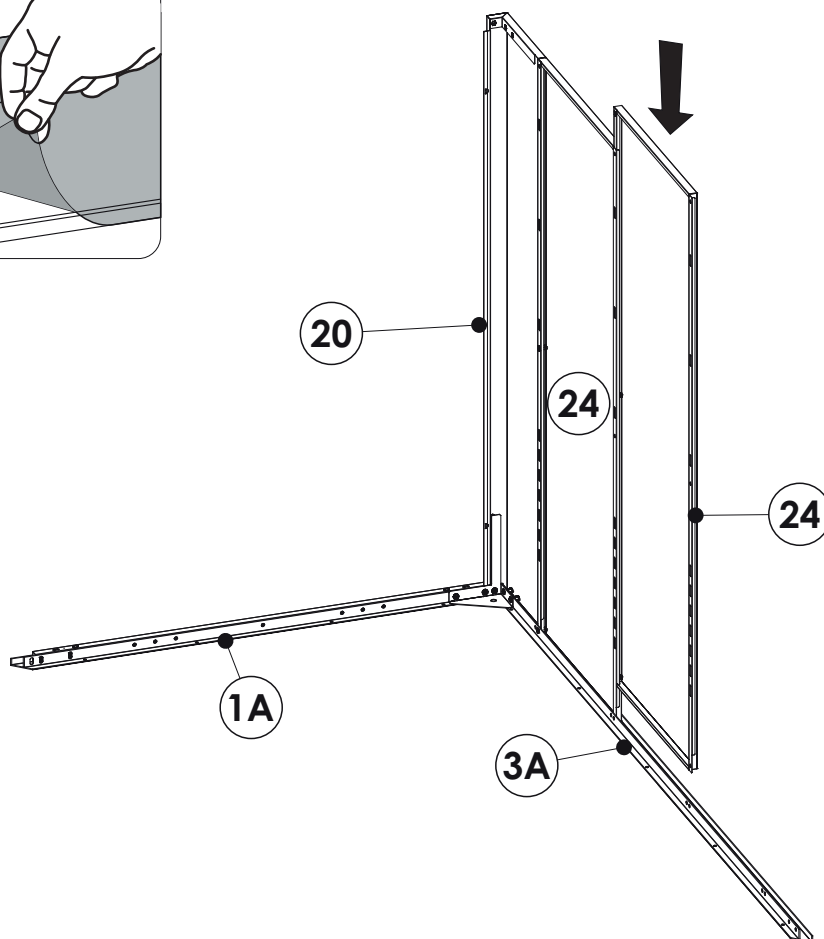
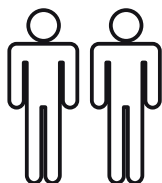
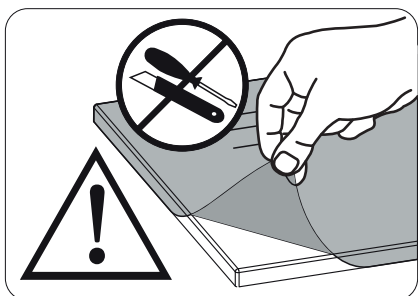

7

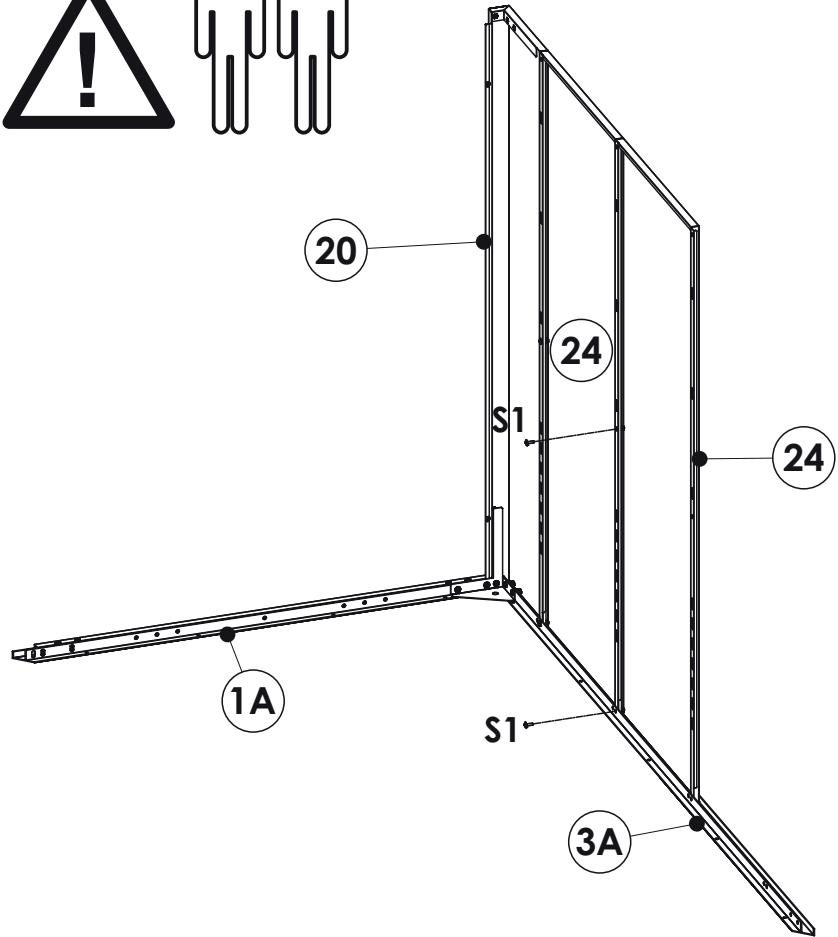
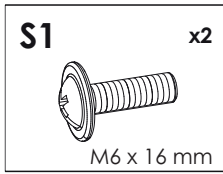

8

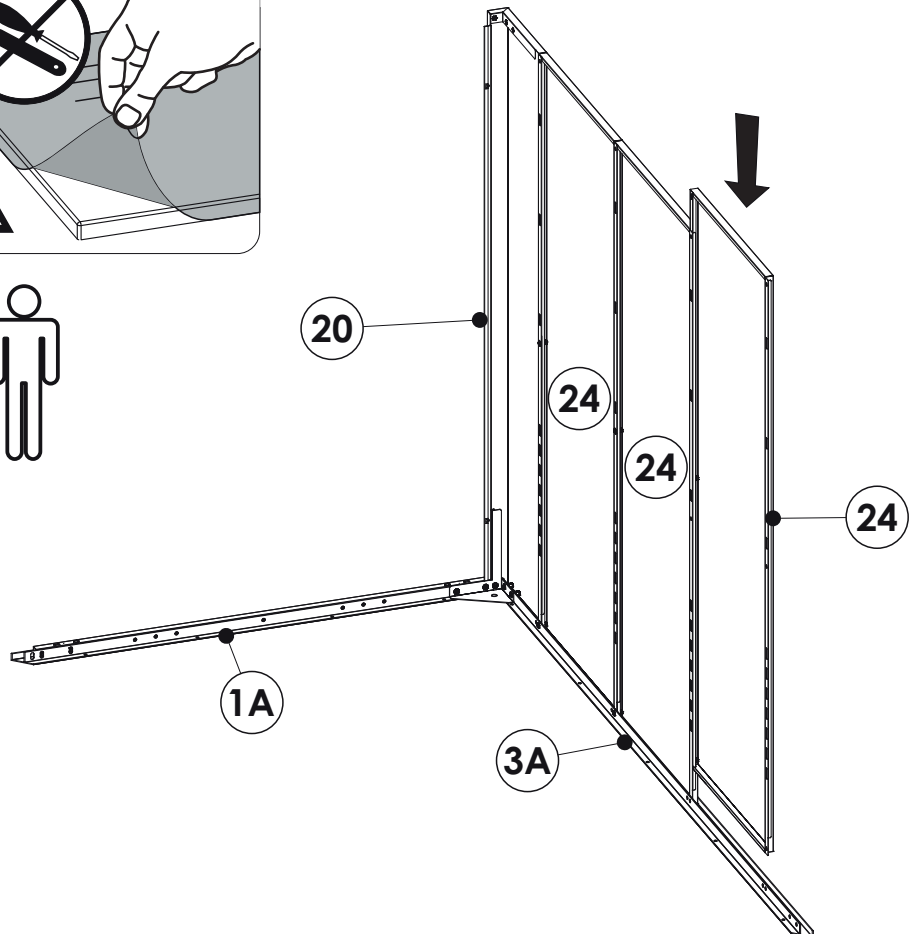
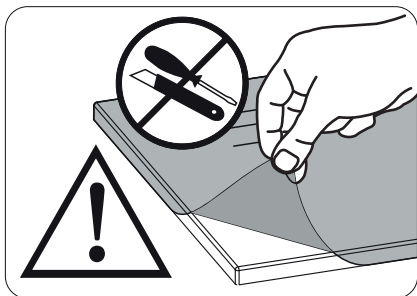

9

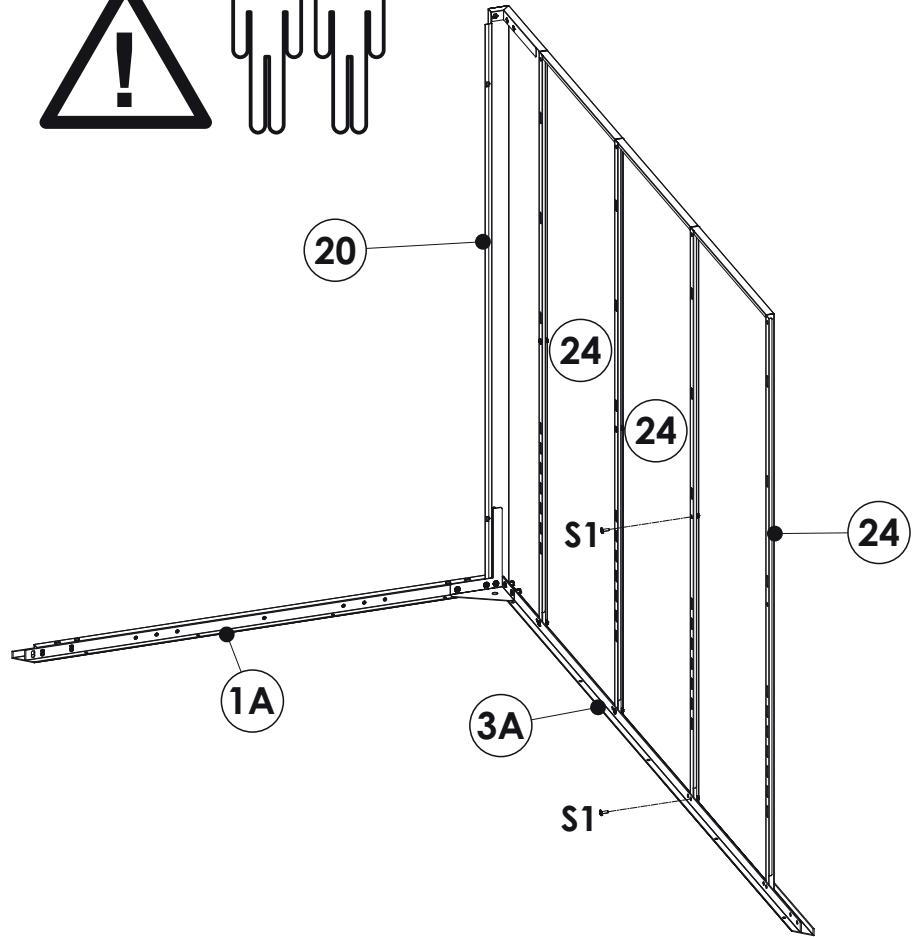
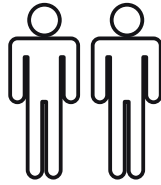
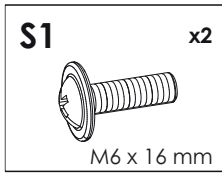

10

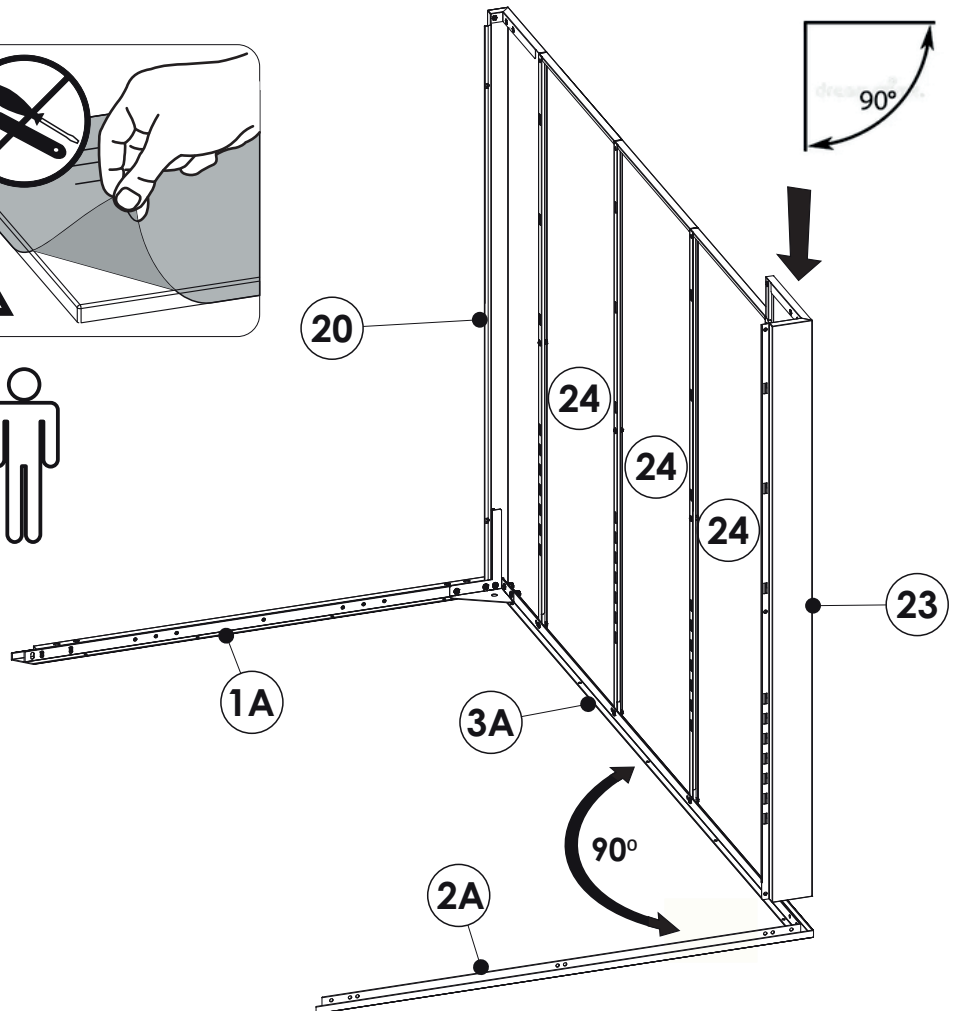
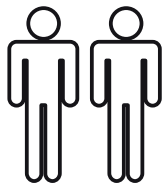
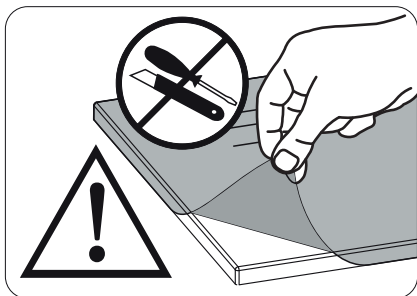

11

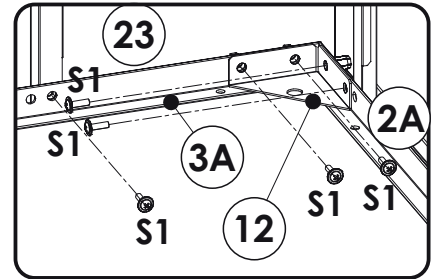
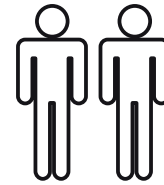
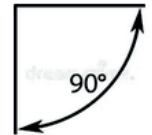
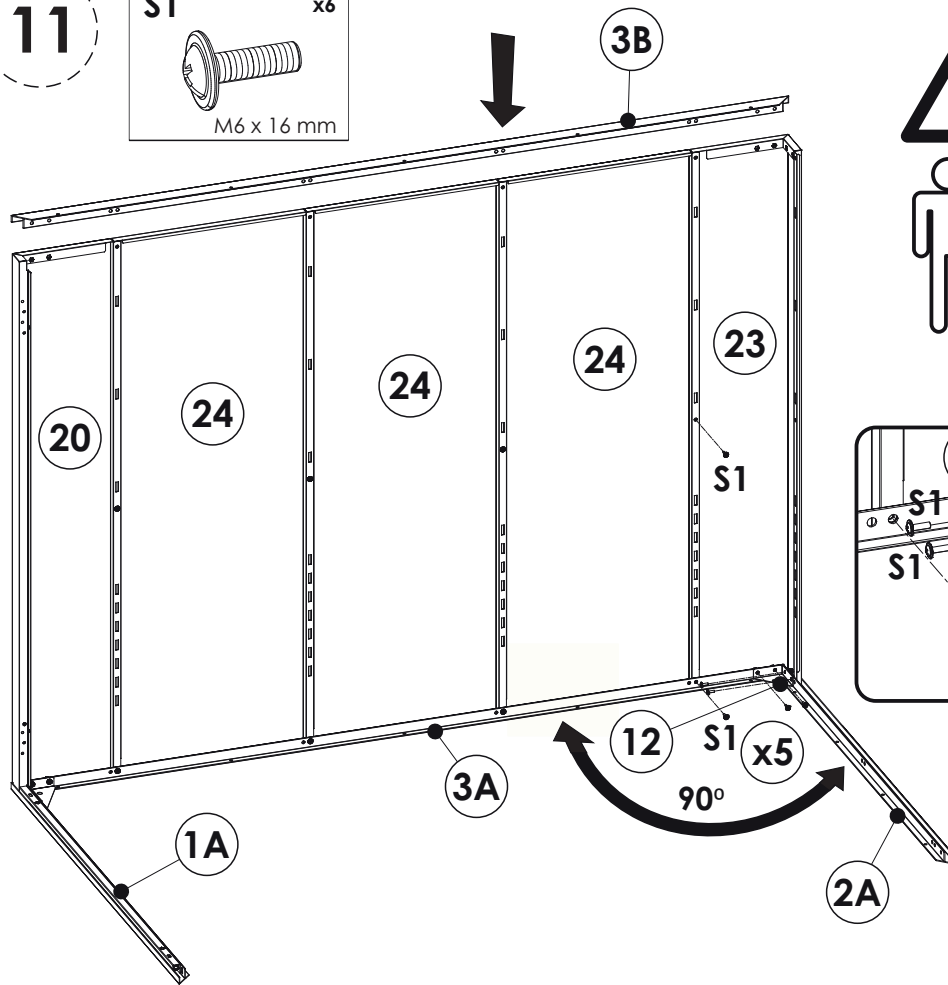
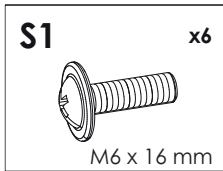

12

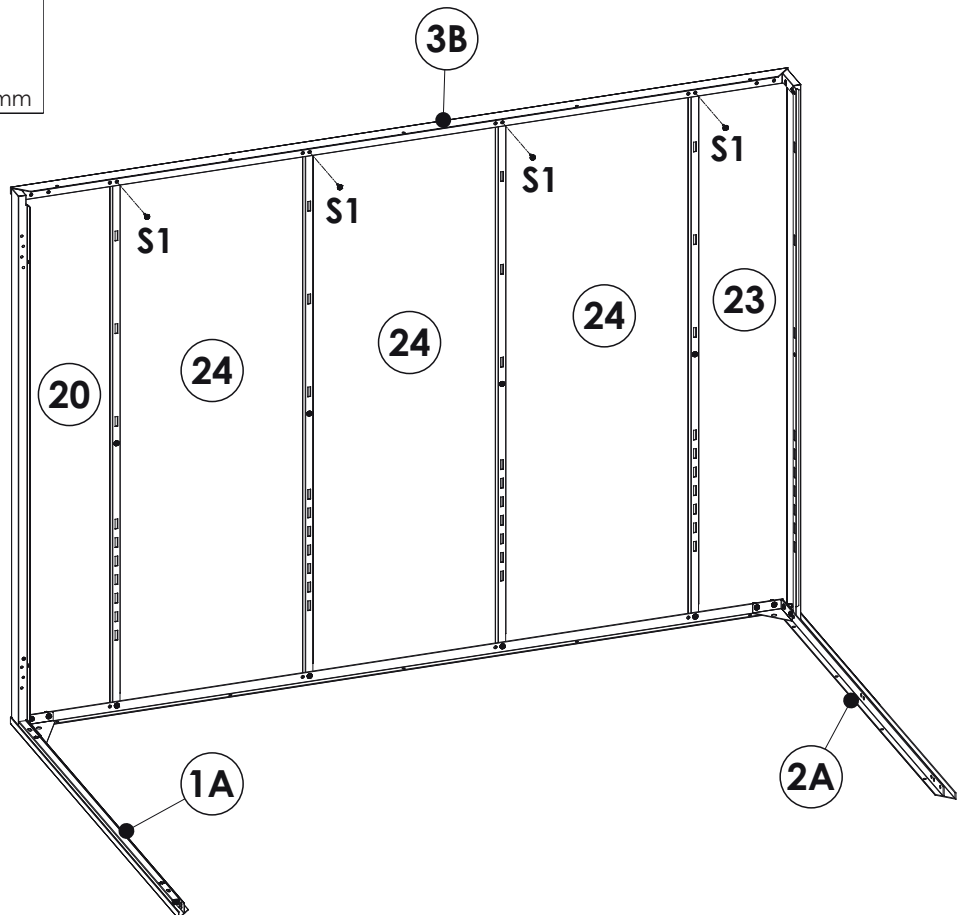
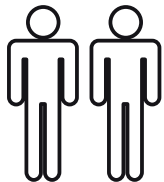
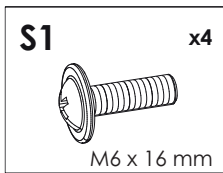

13

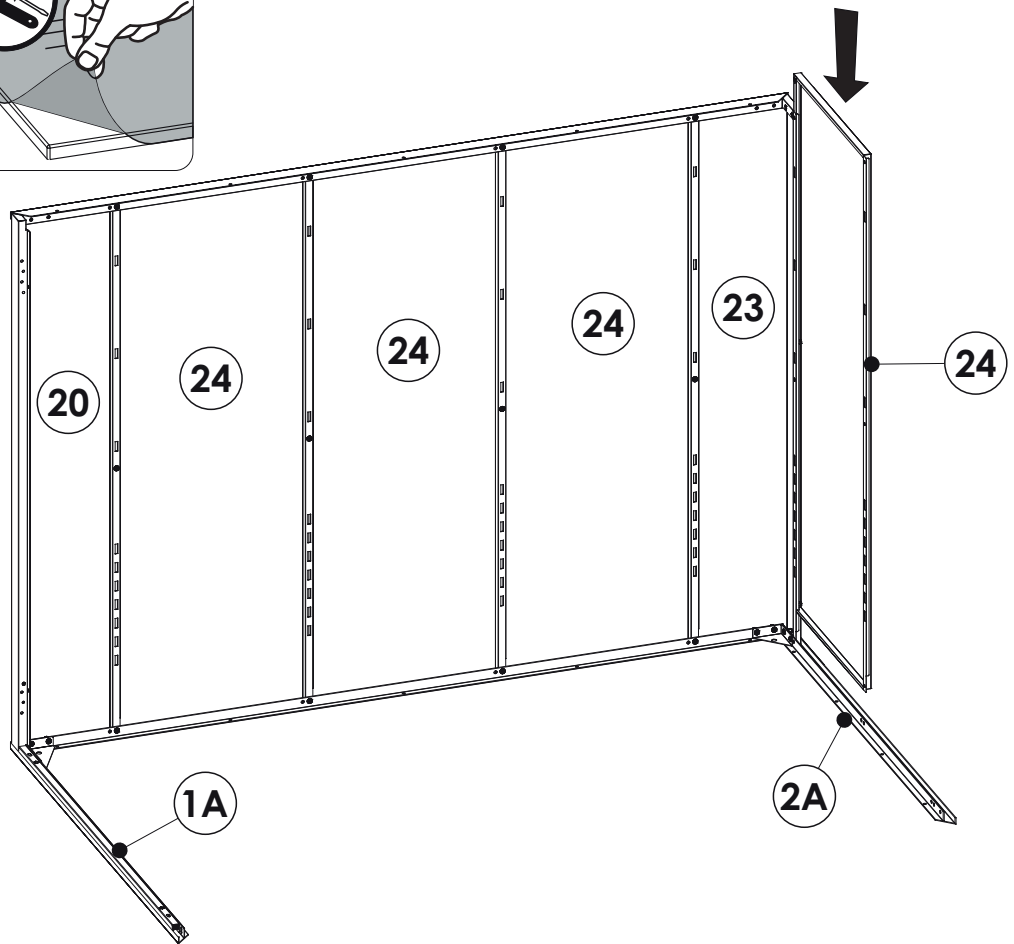
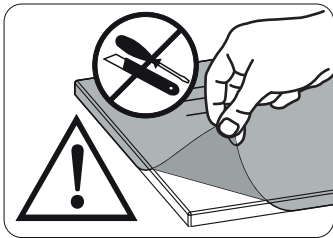

14

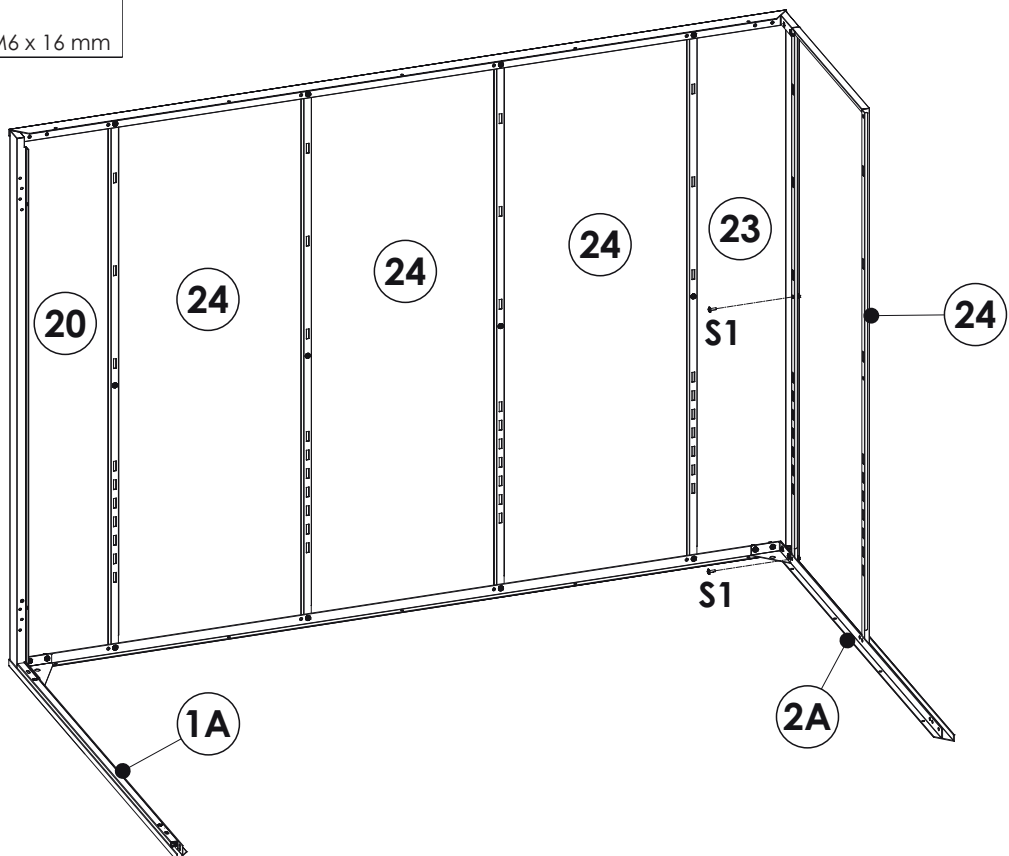
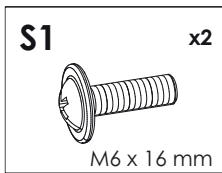

15

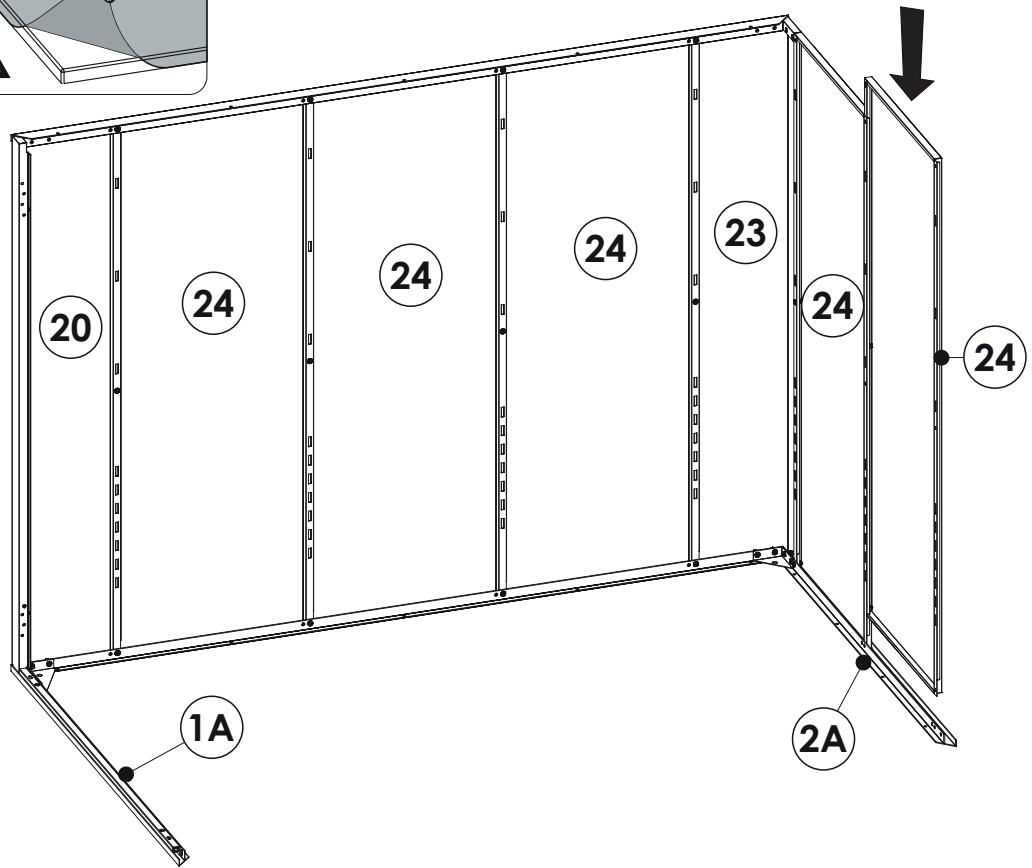
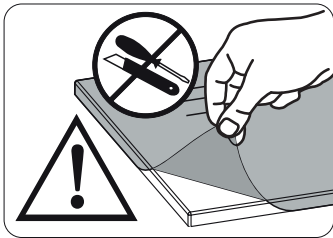

16

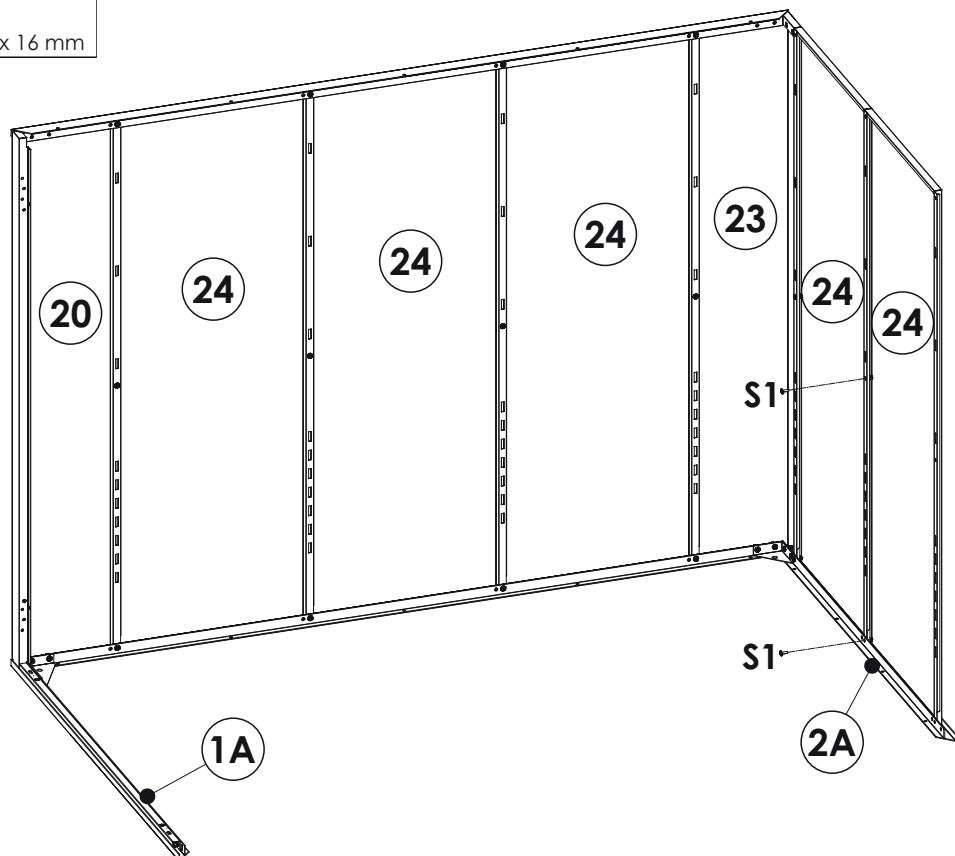
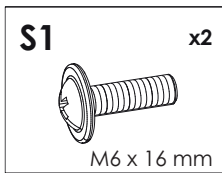

17

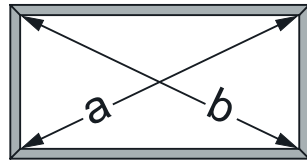
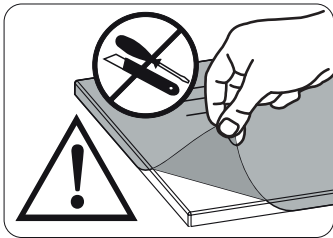

$a = b$

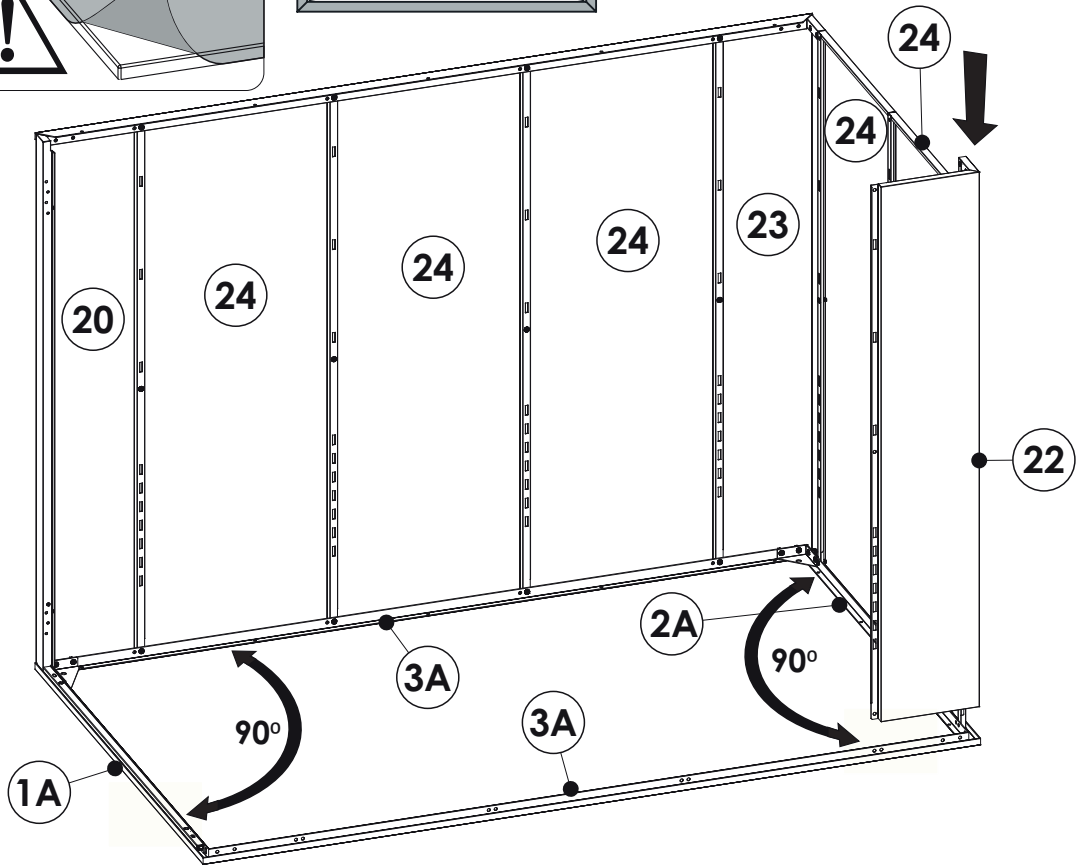
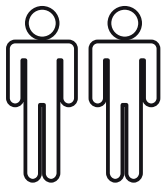

18

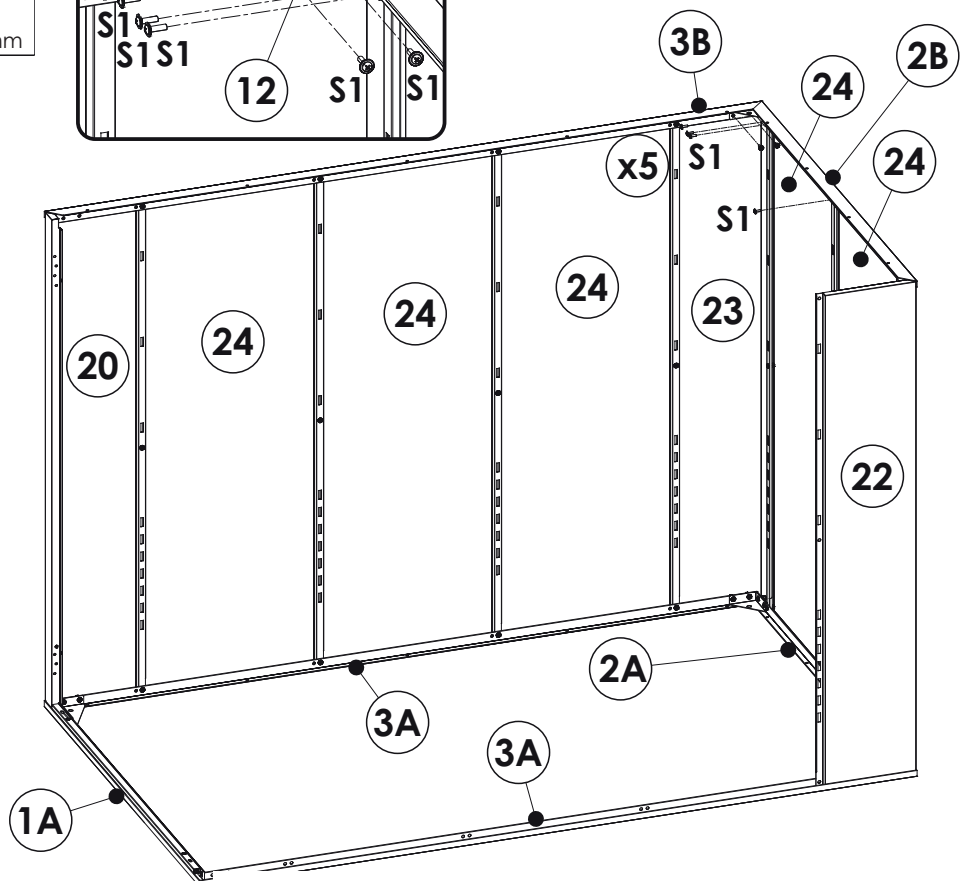
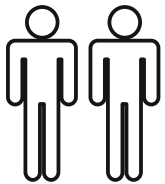
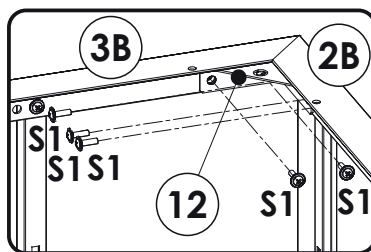
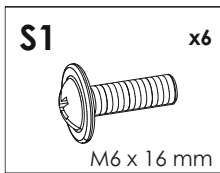

19

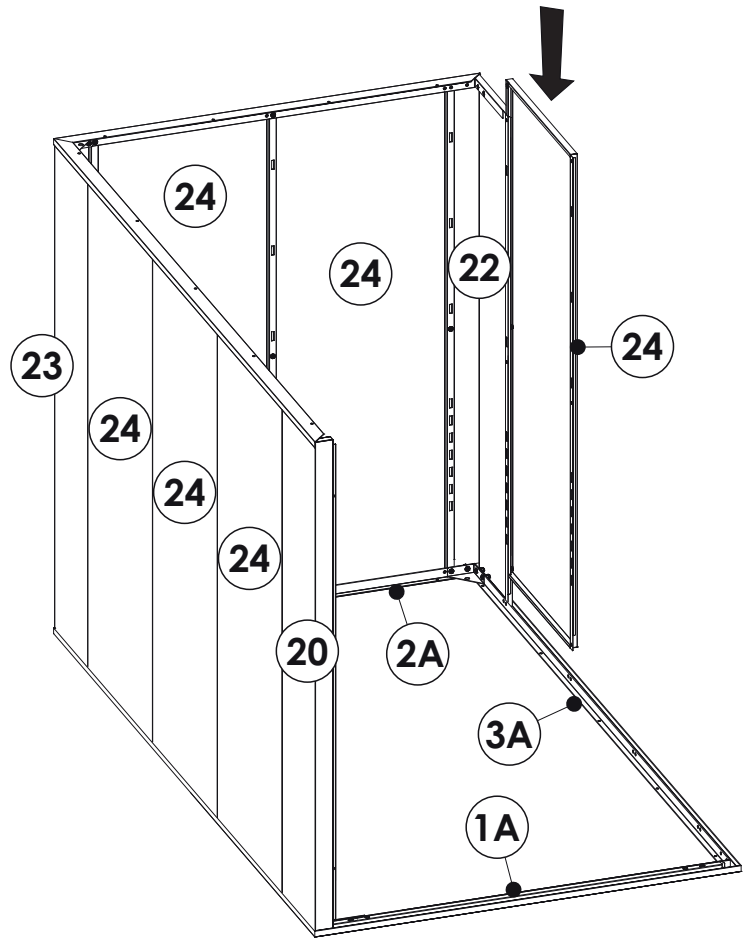
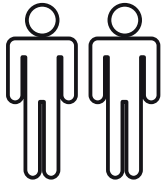
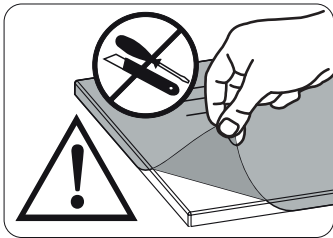

20

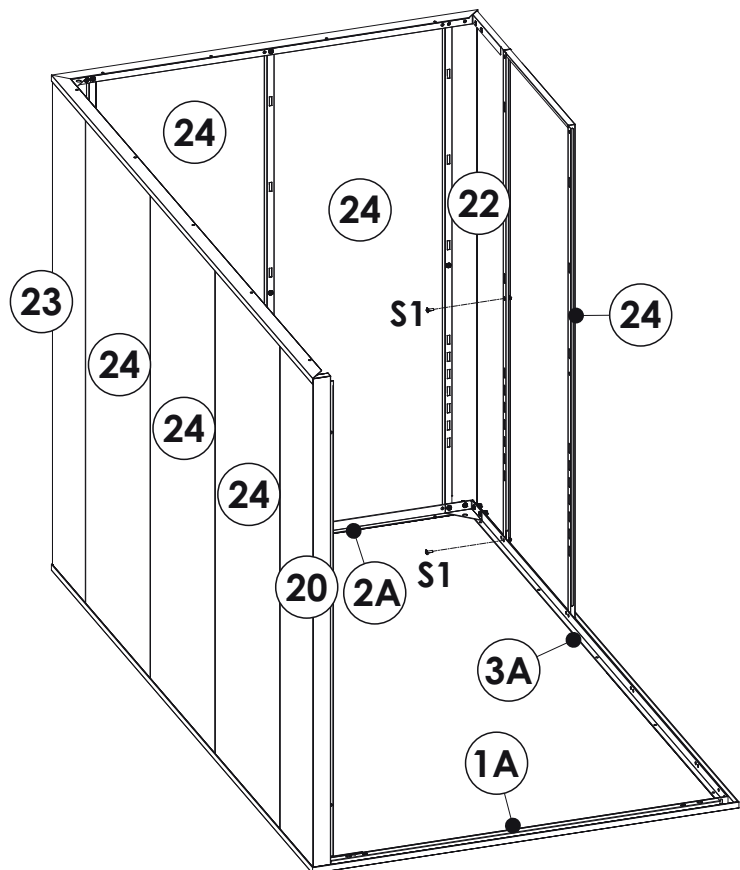
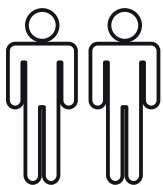
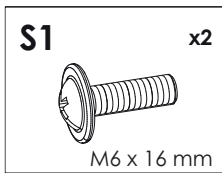

21

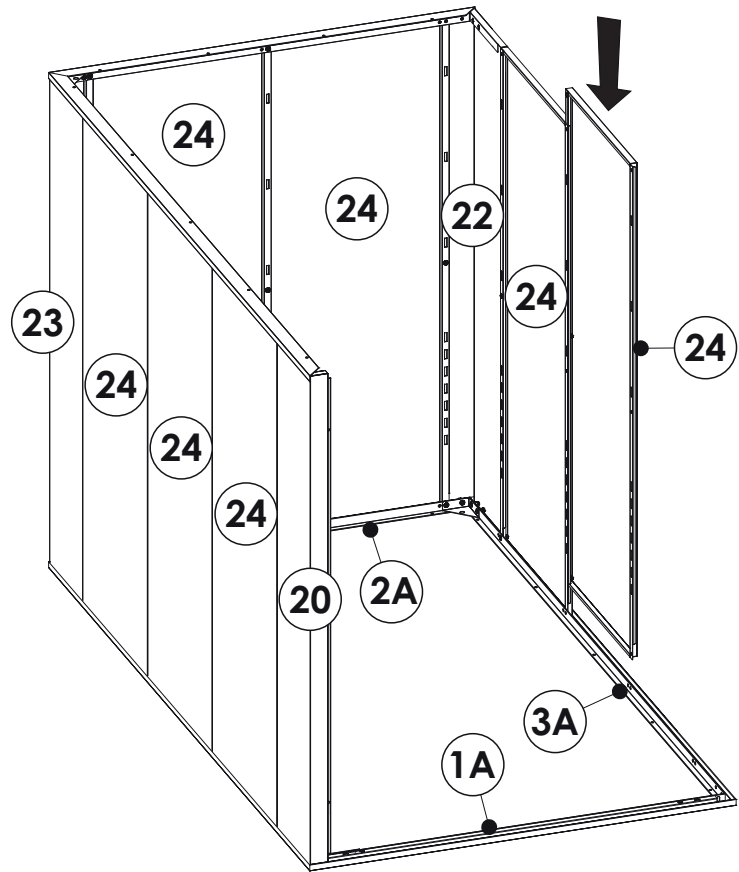
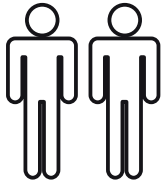
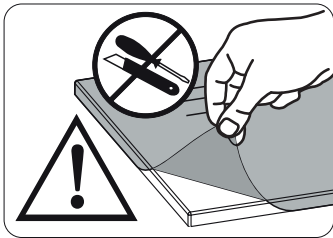

22

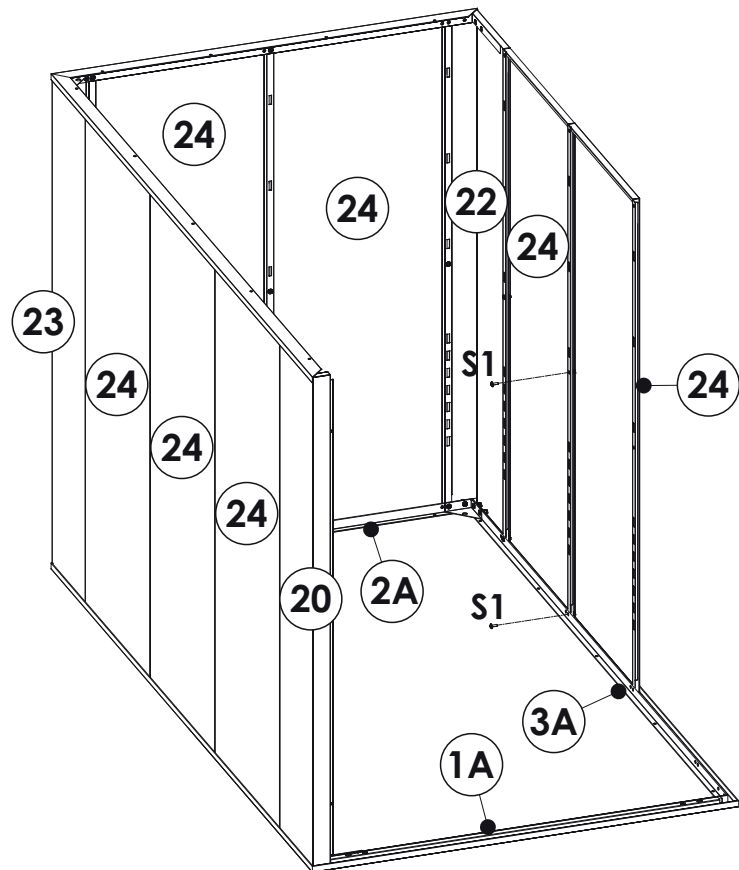
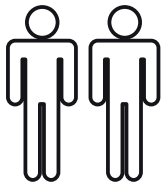
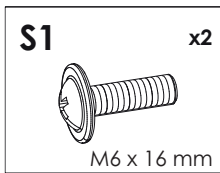

23

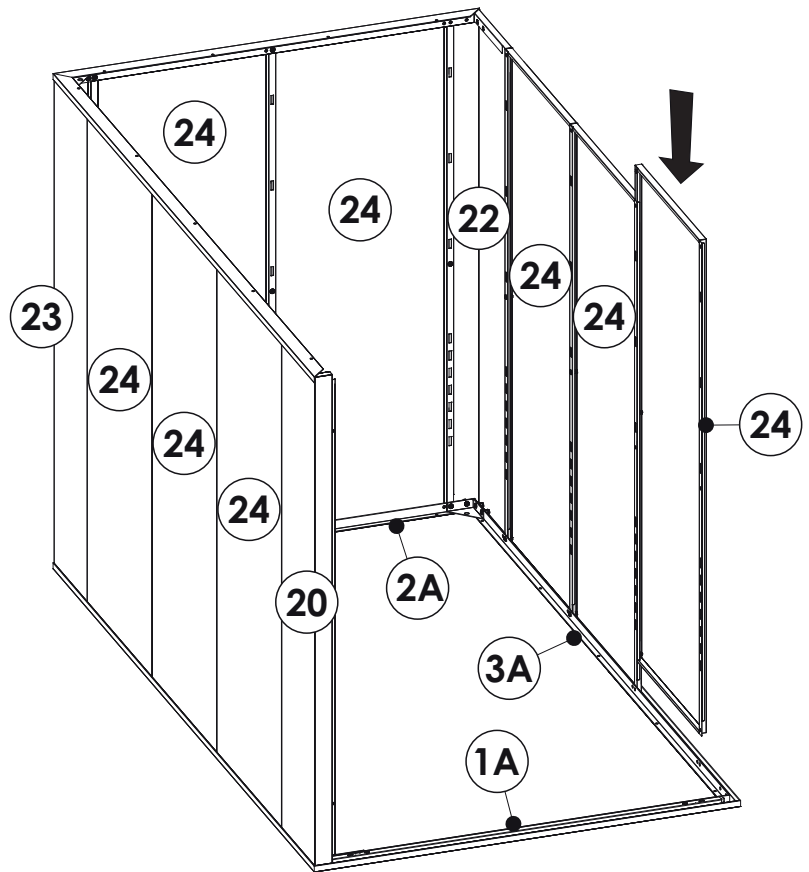
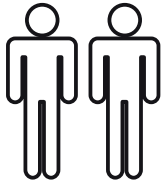
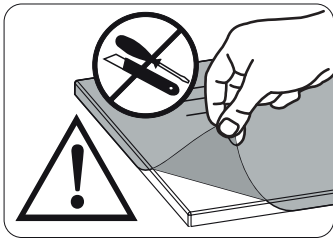

24

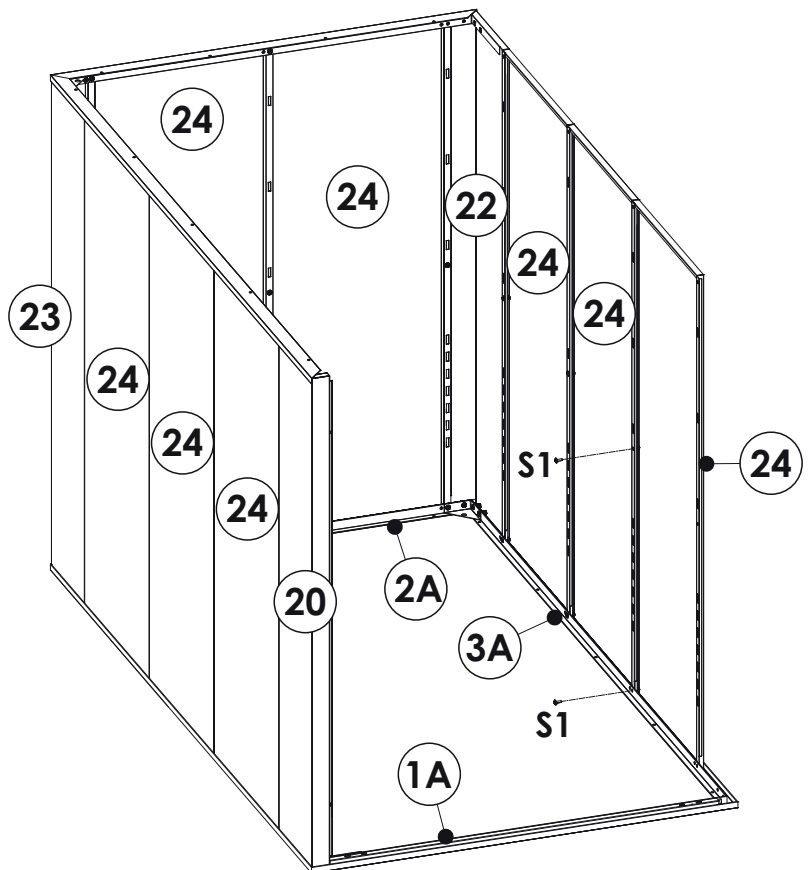
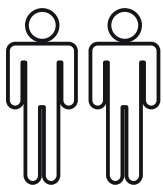
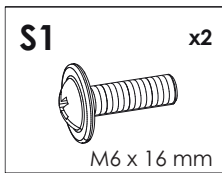

25

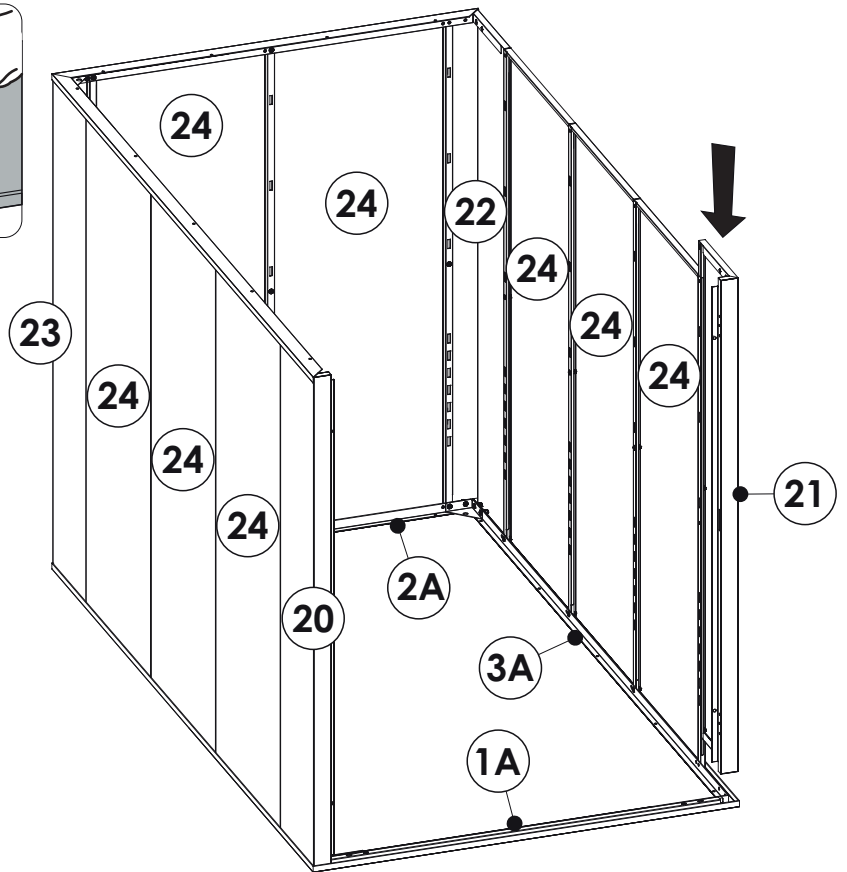
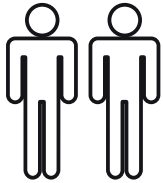
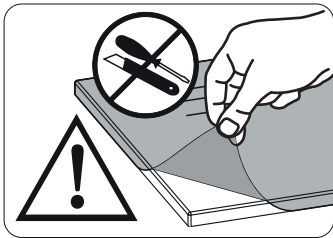

26

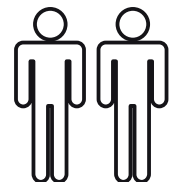
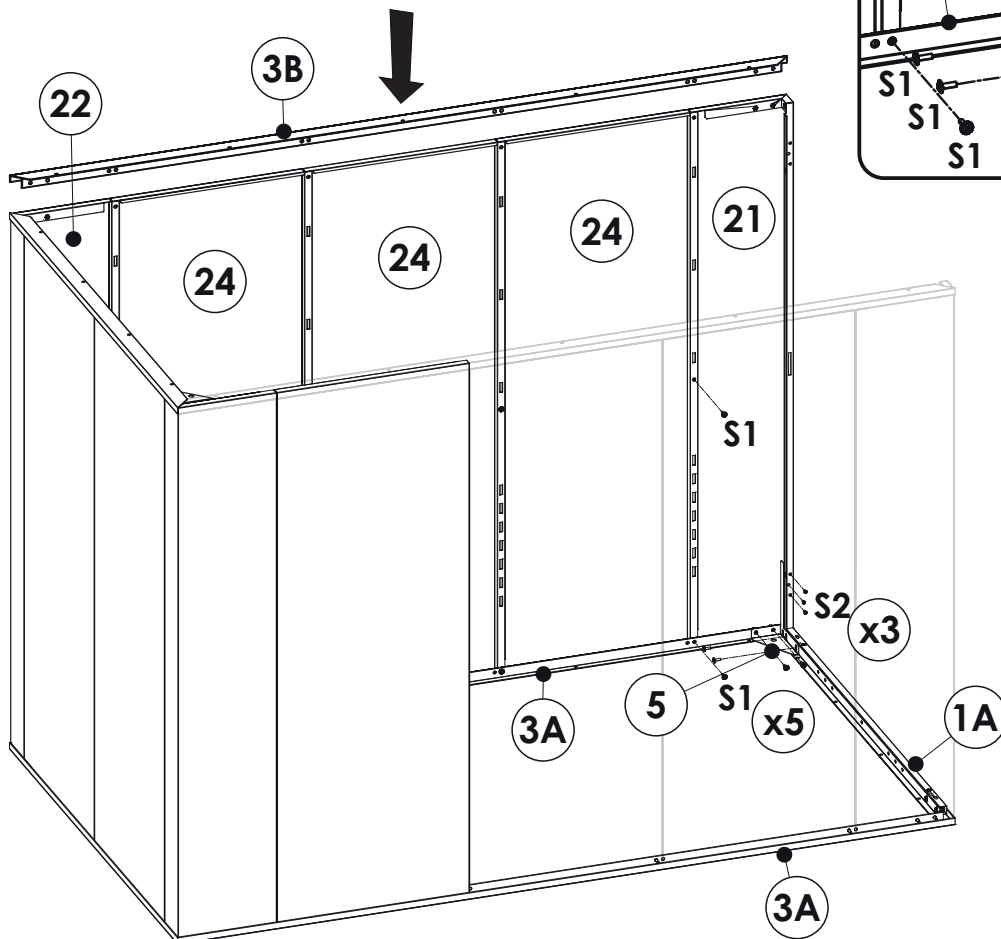
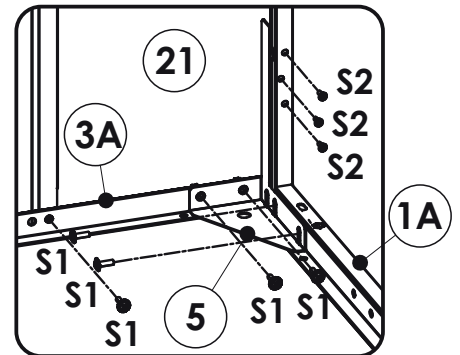
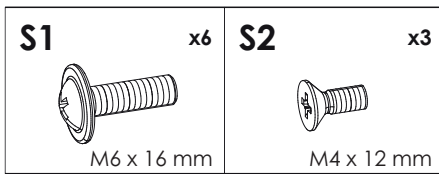

27

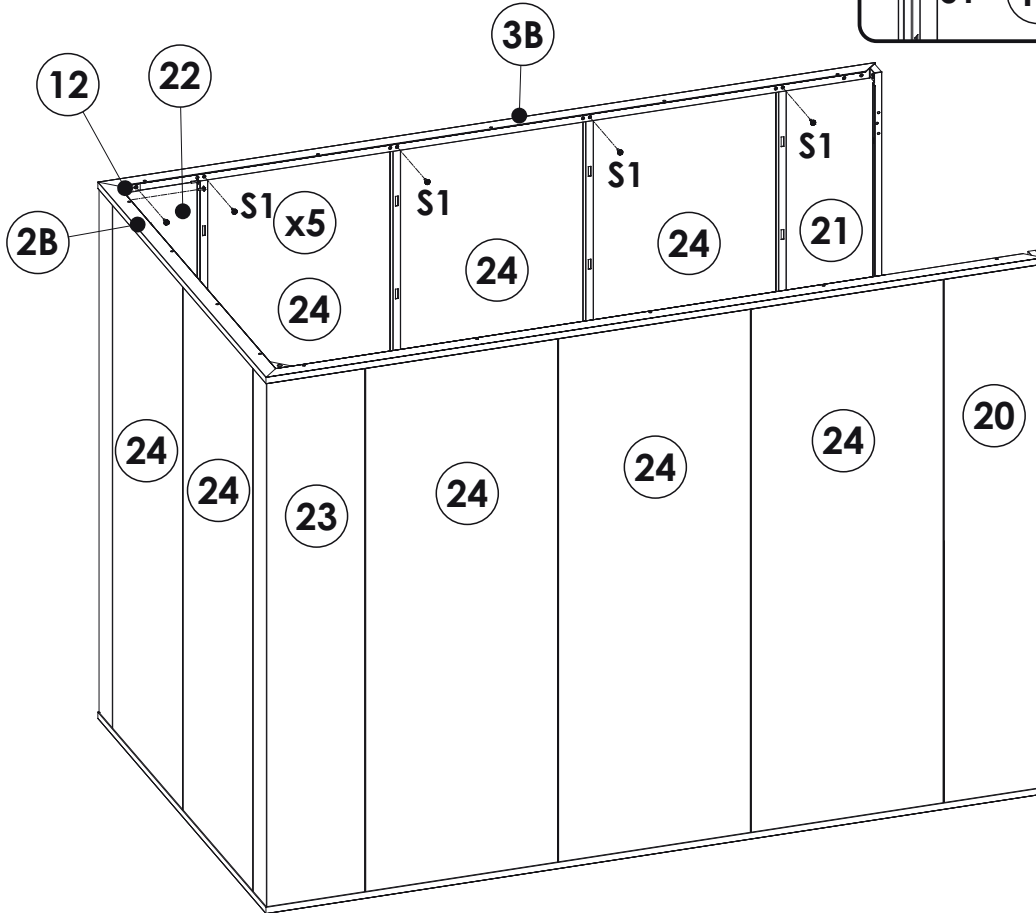
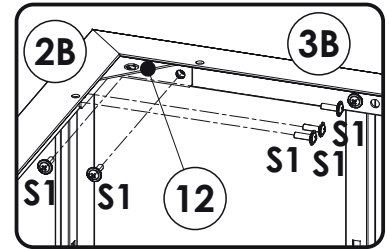
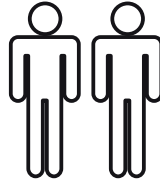
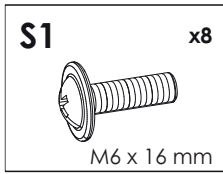

28

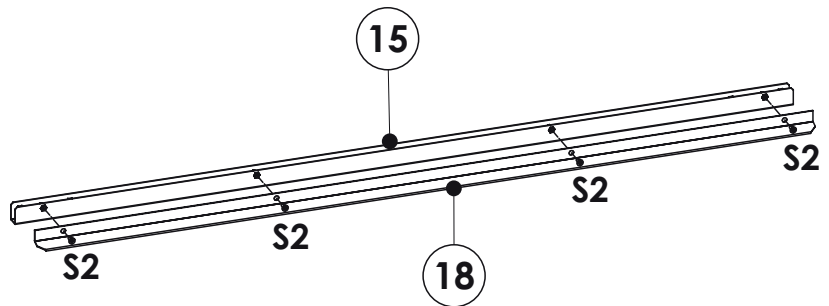
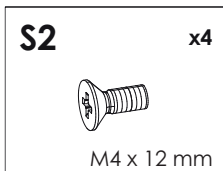

29

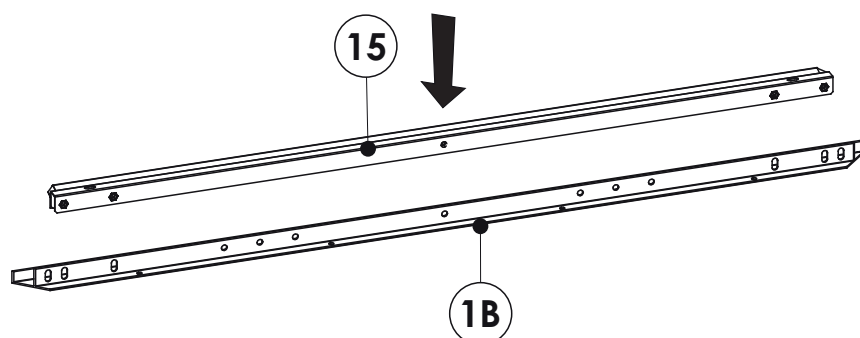

30

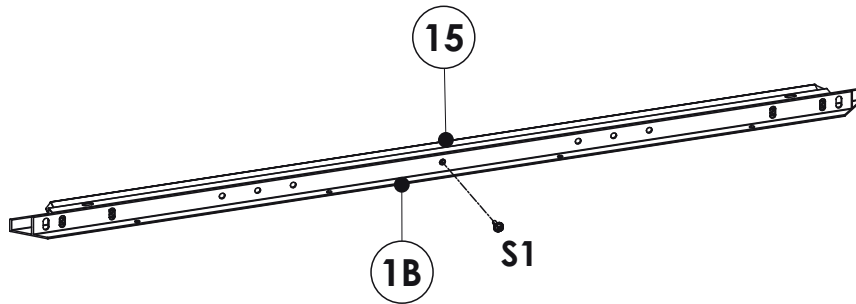
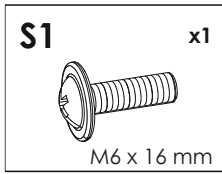

31

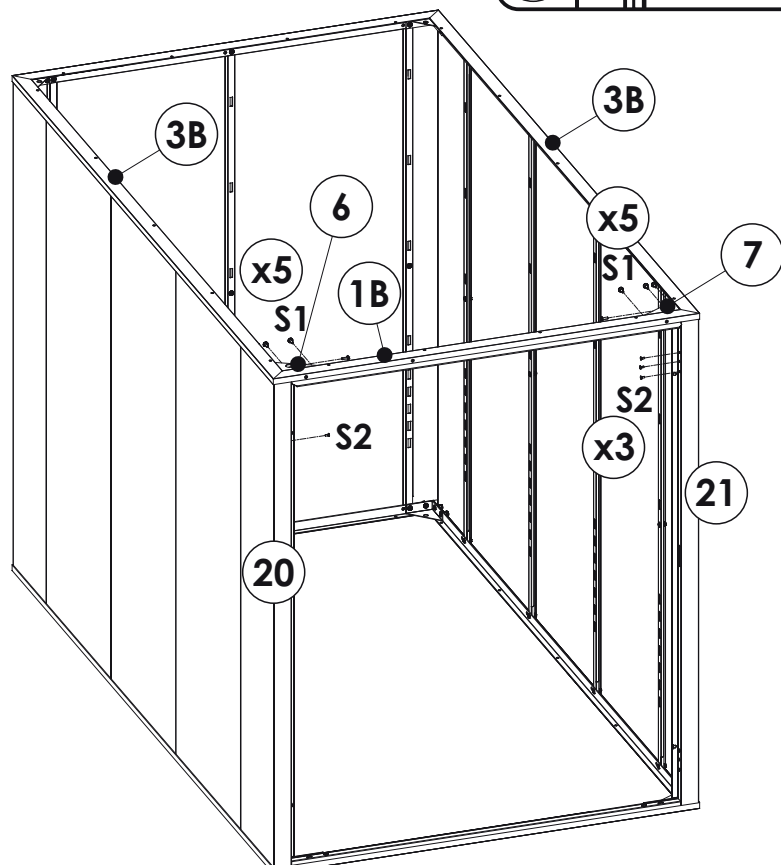
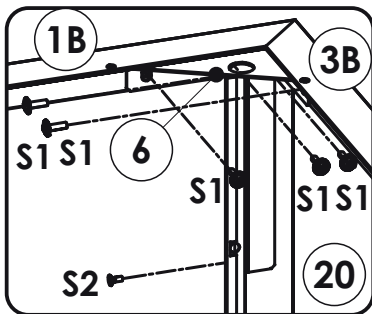
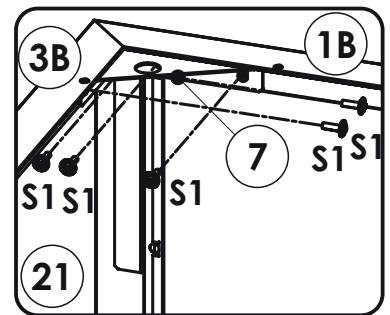
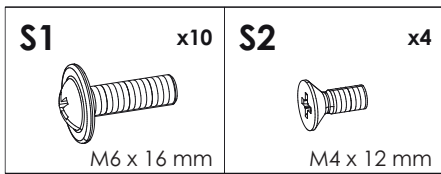

32

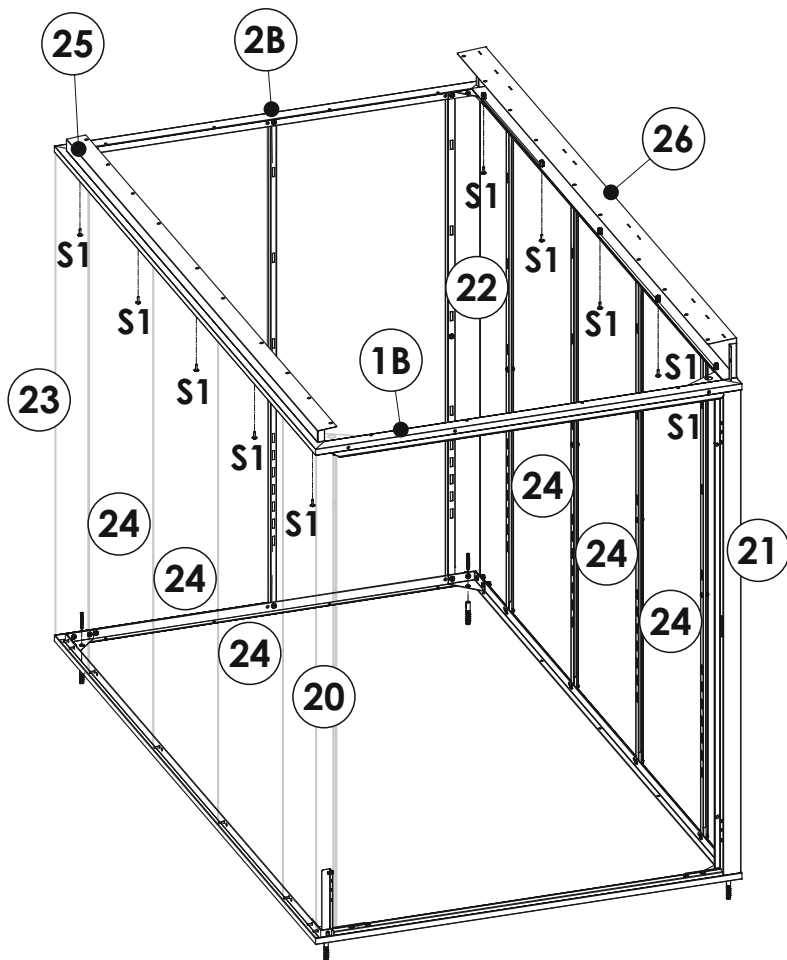
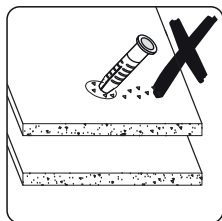
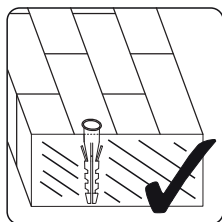
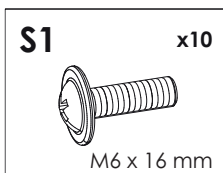

33

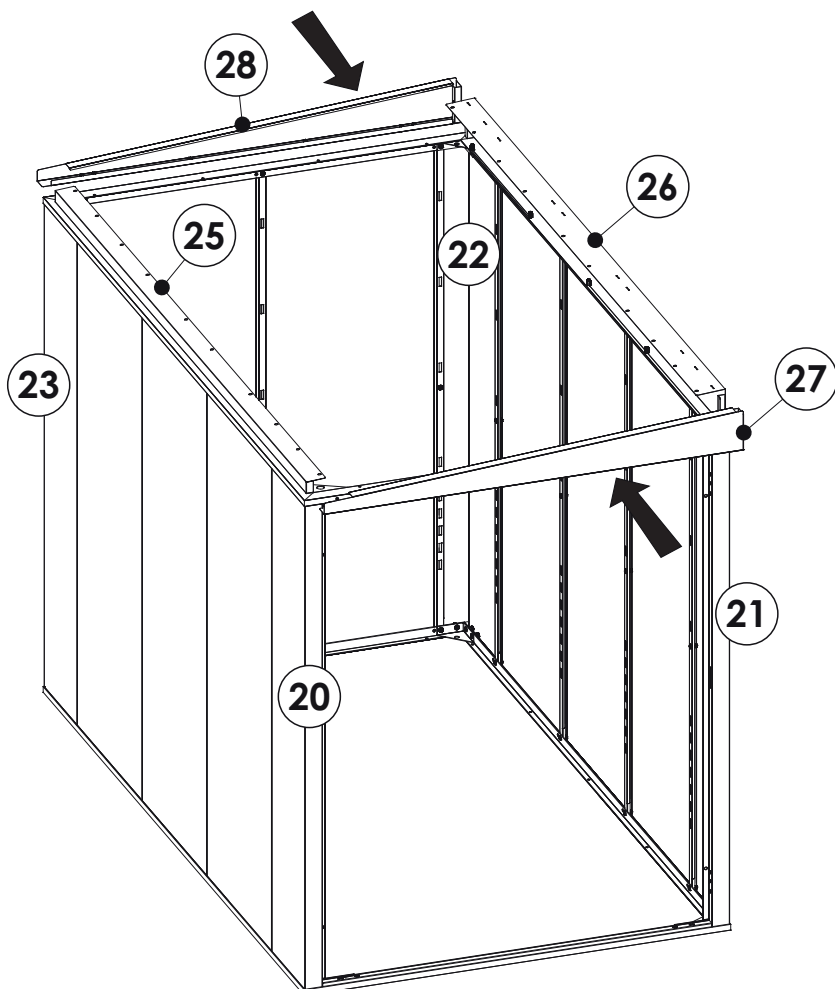
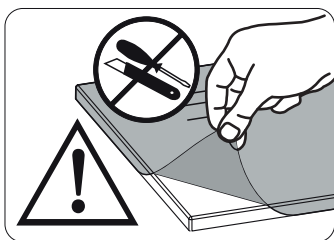

34

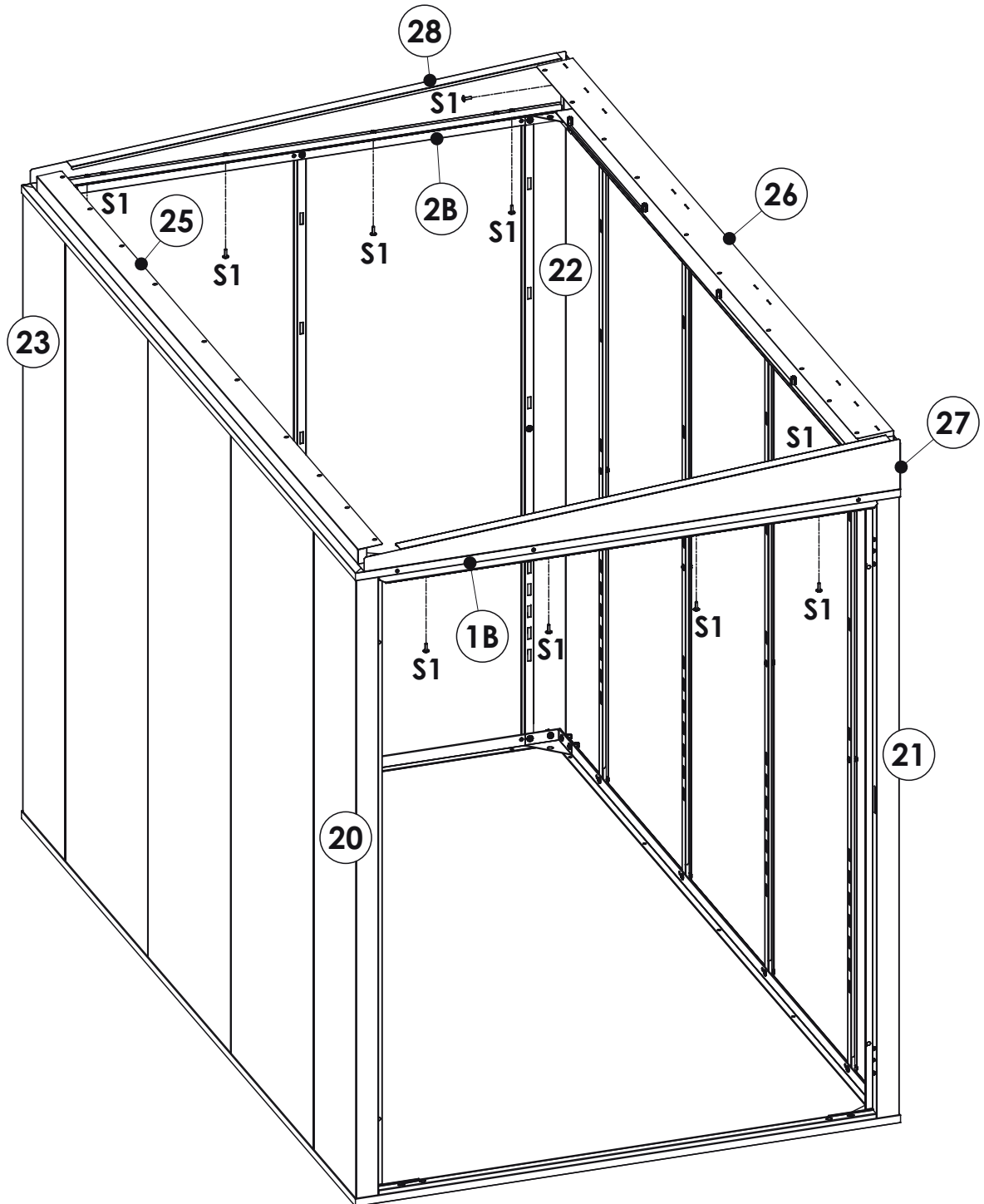
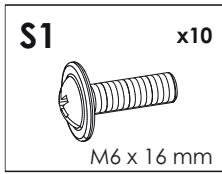

35

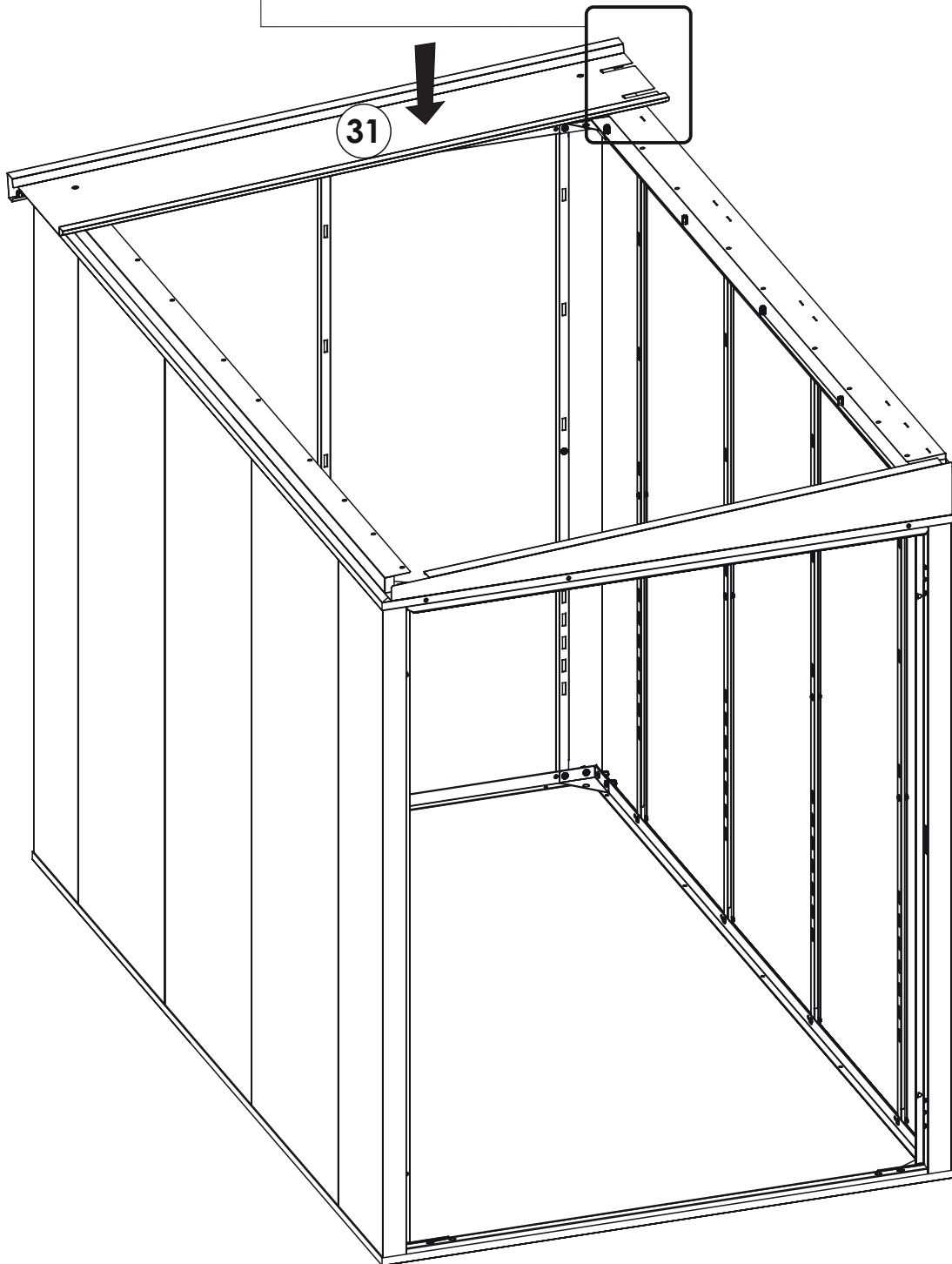
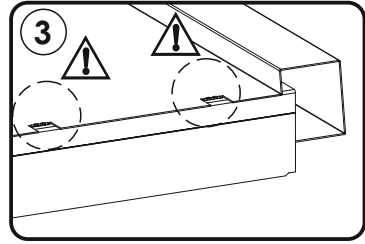
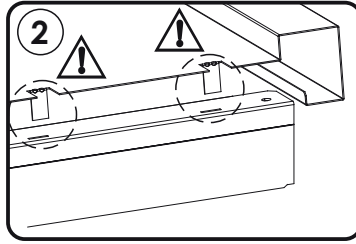
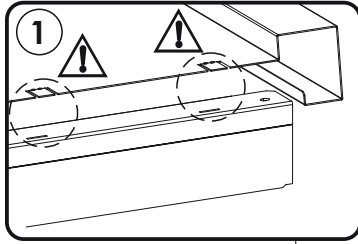
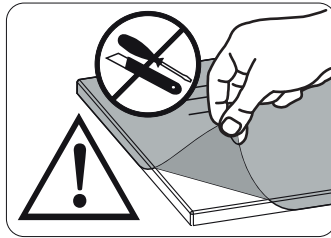
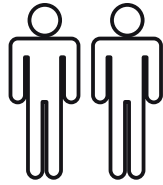

36

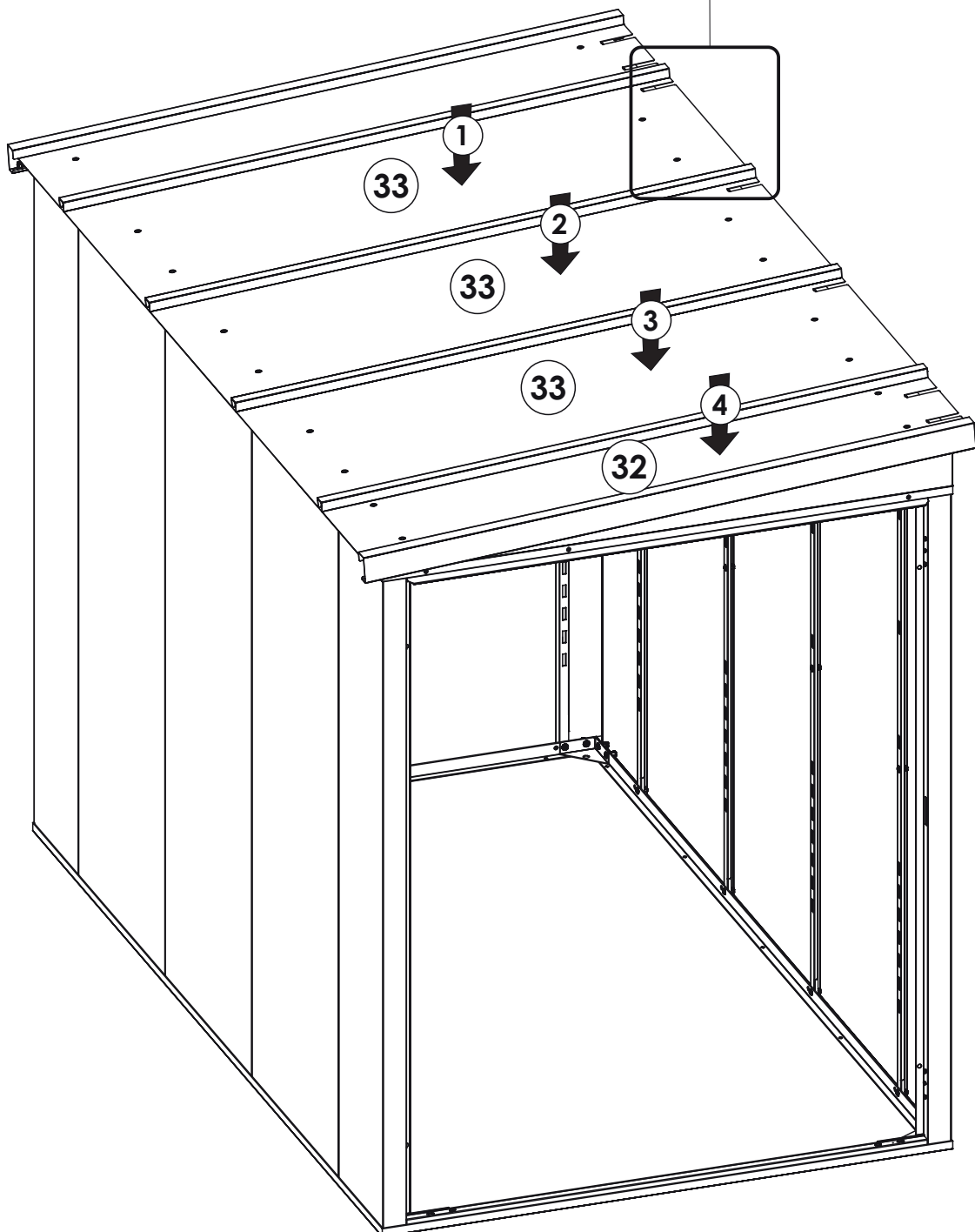
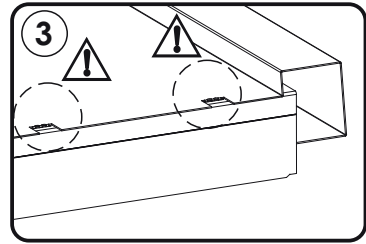
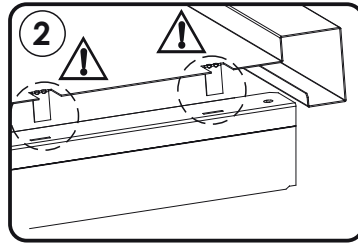
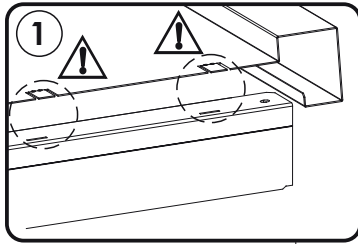
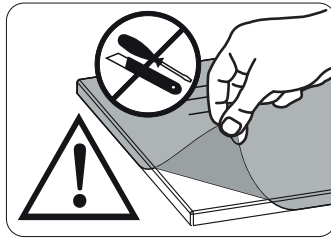
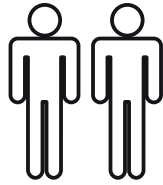

37

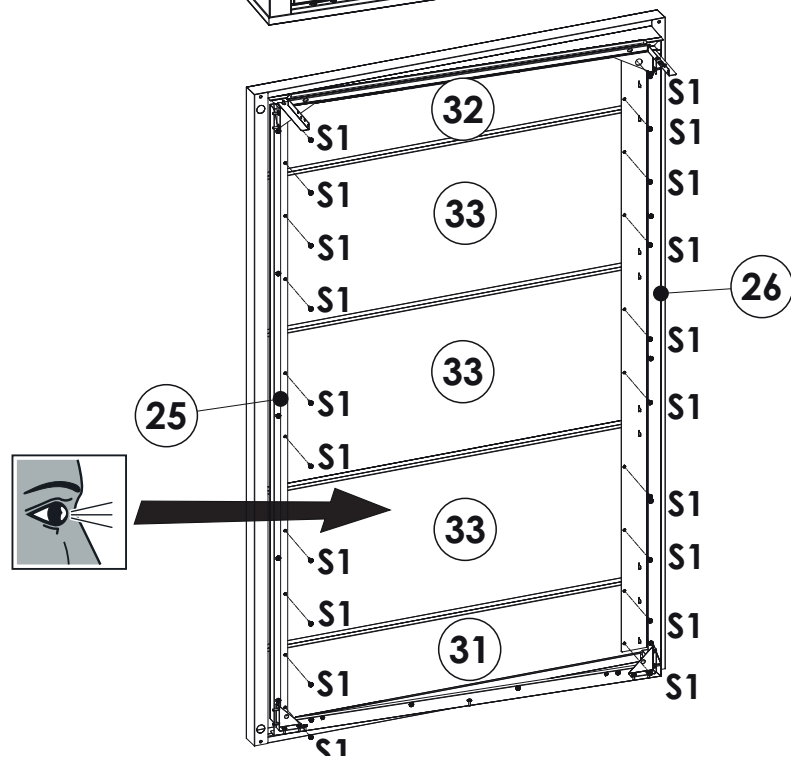
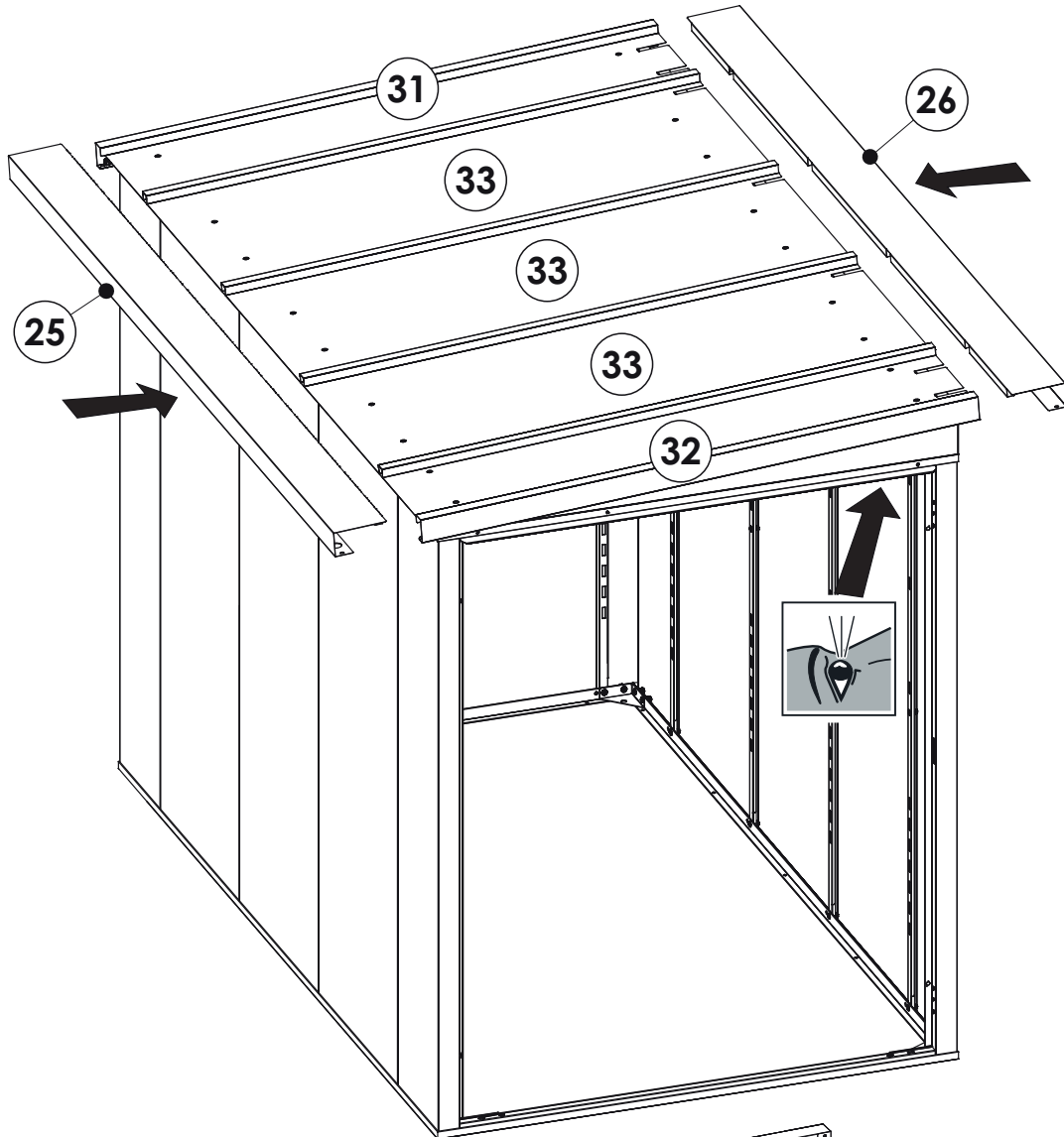
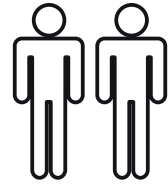
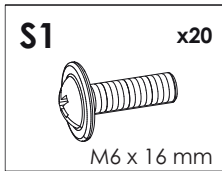

38

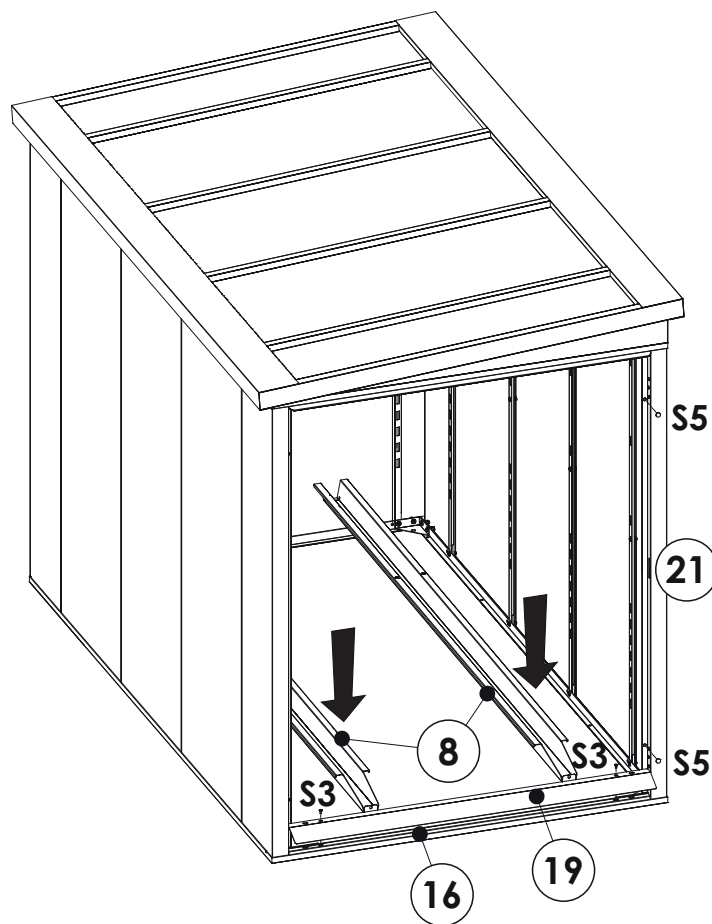
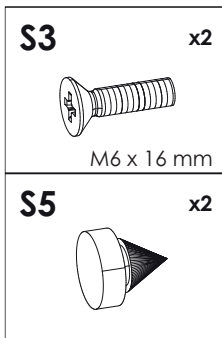

39

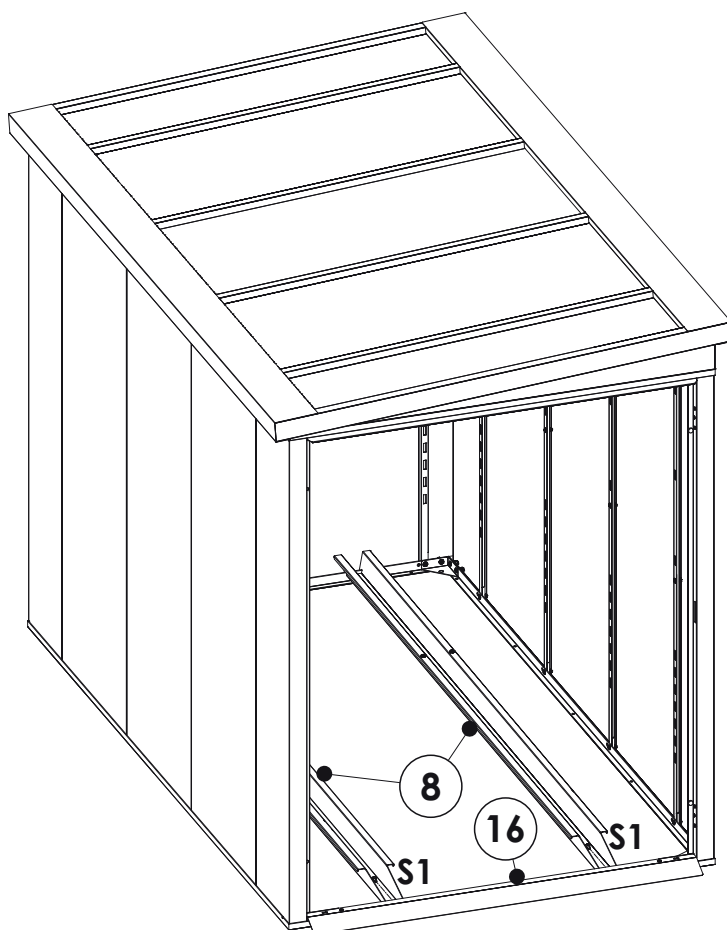
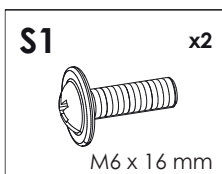

40

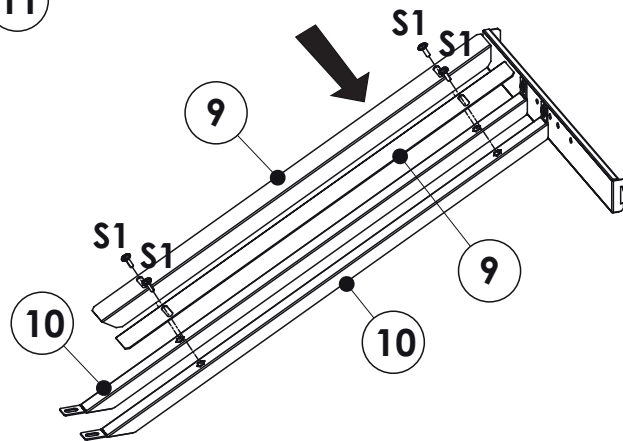
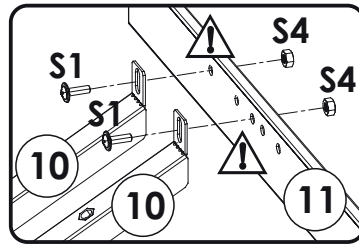
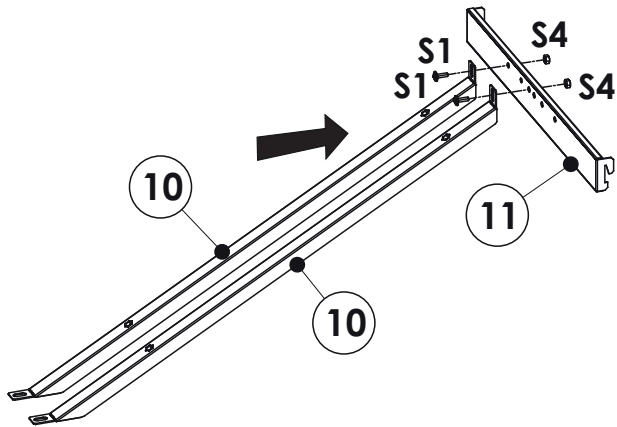
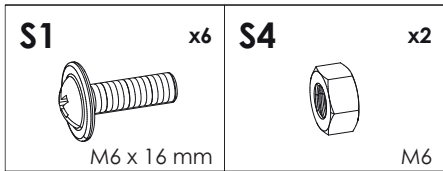

41

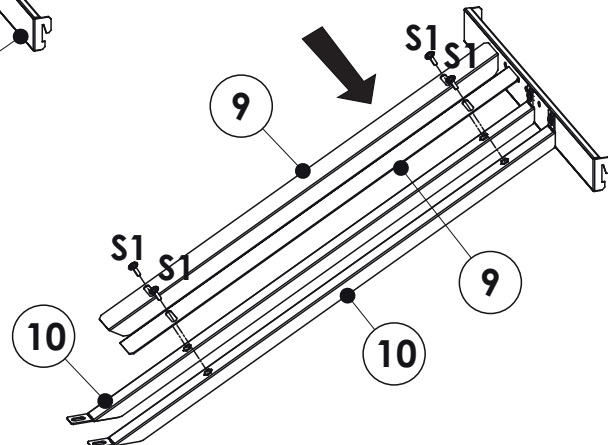
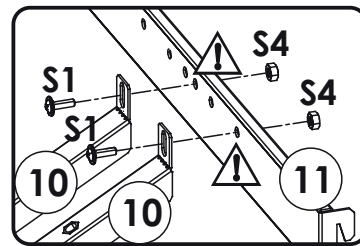
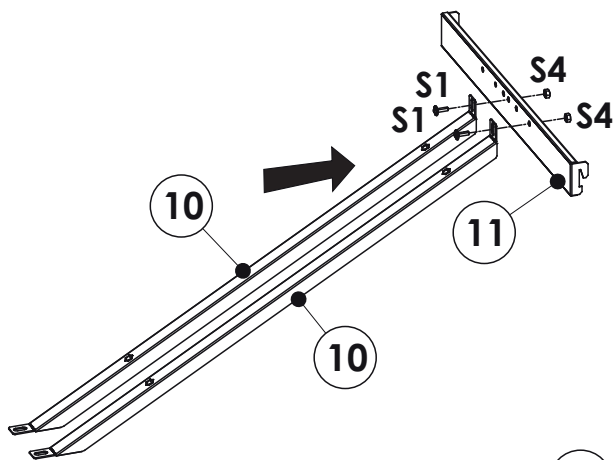
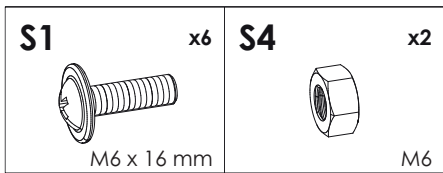

42

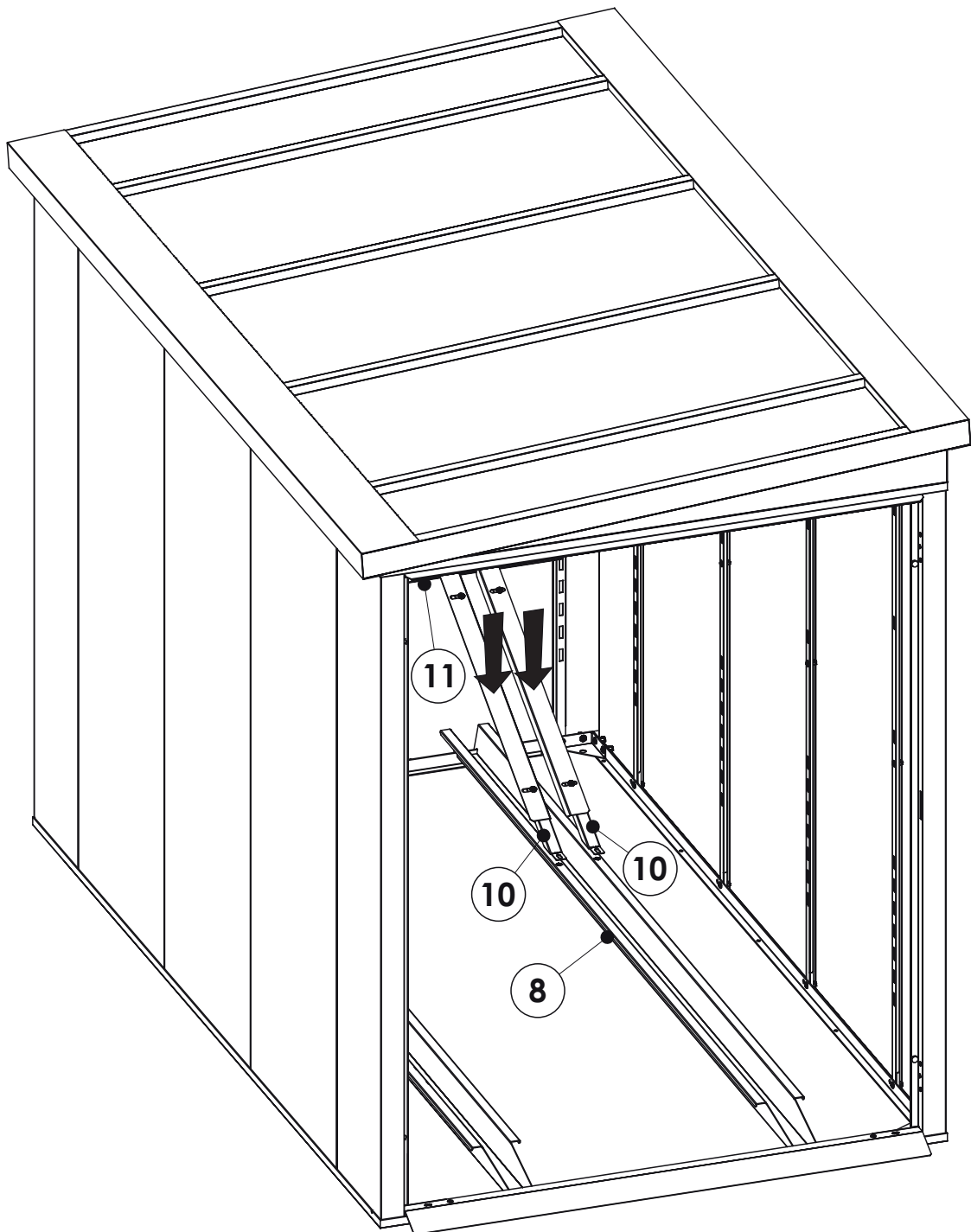
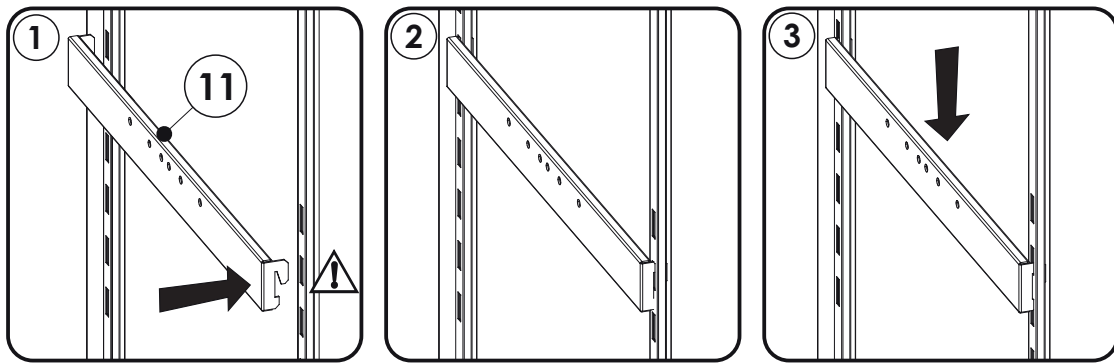

43

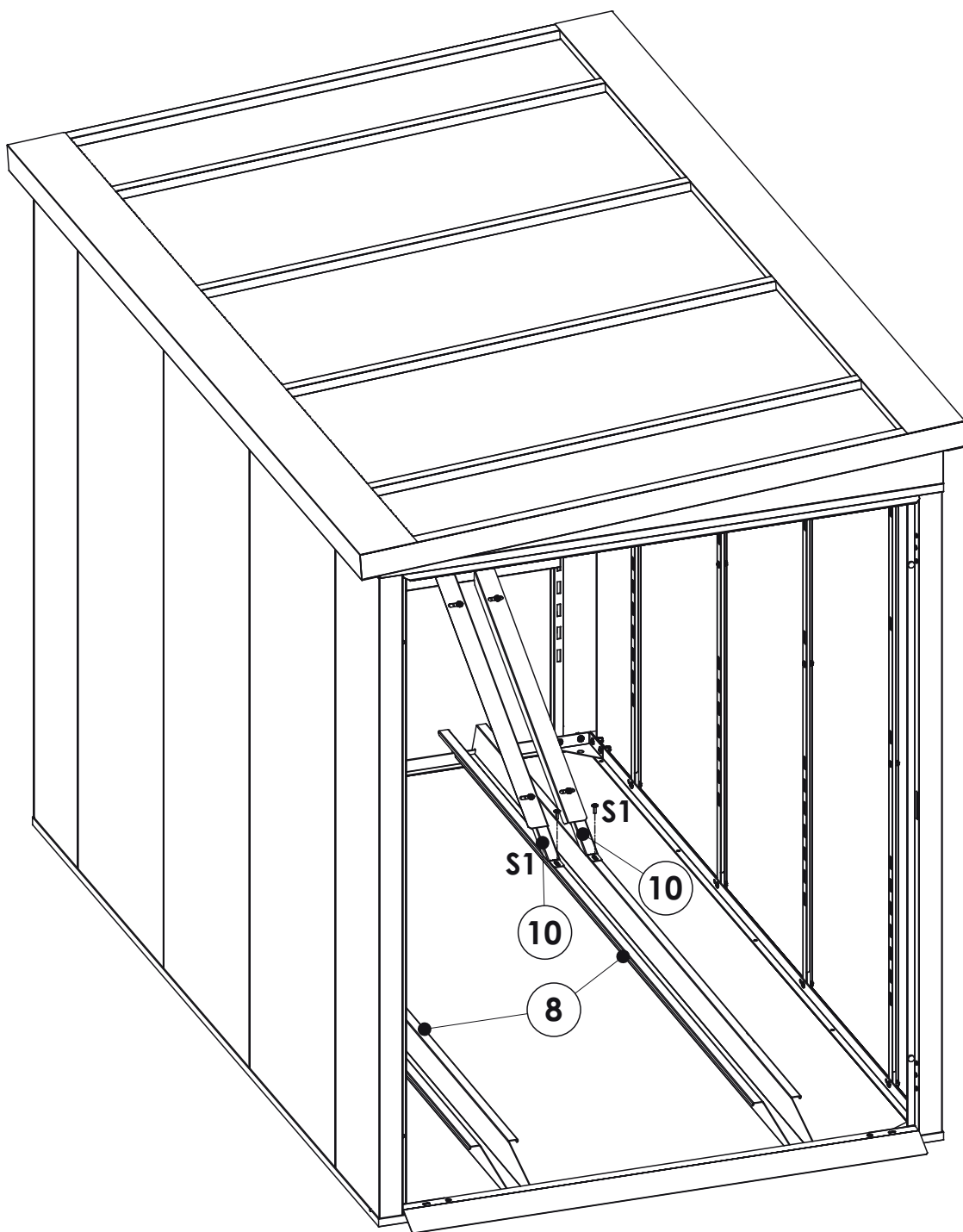
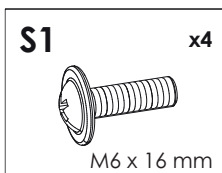

44

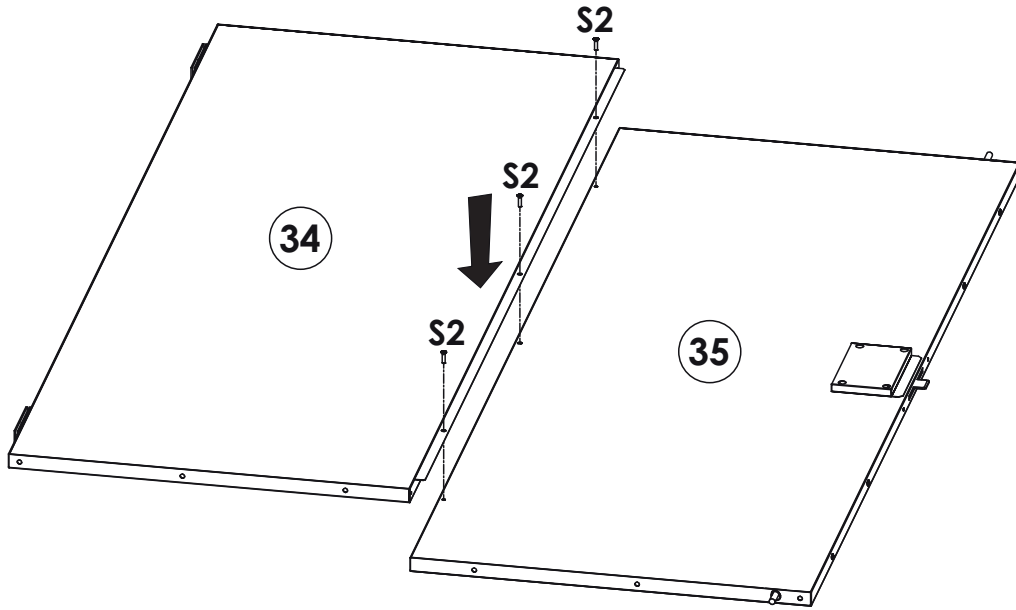
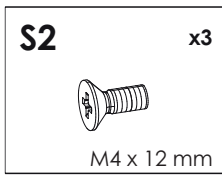

45

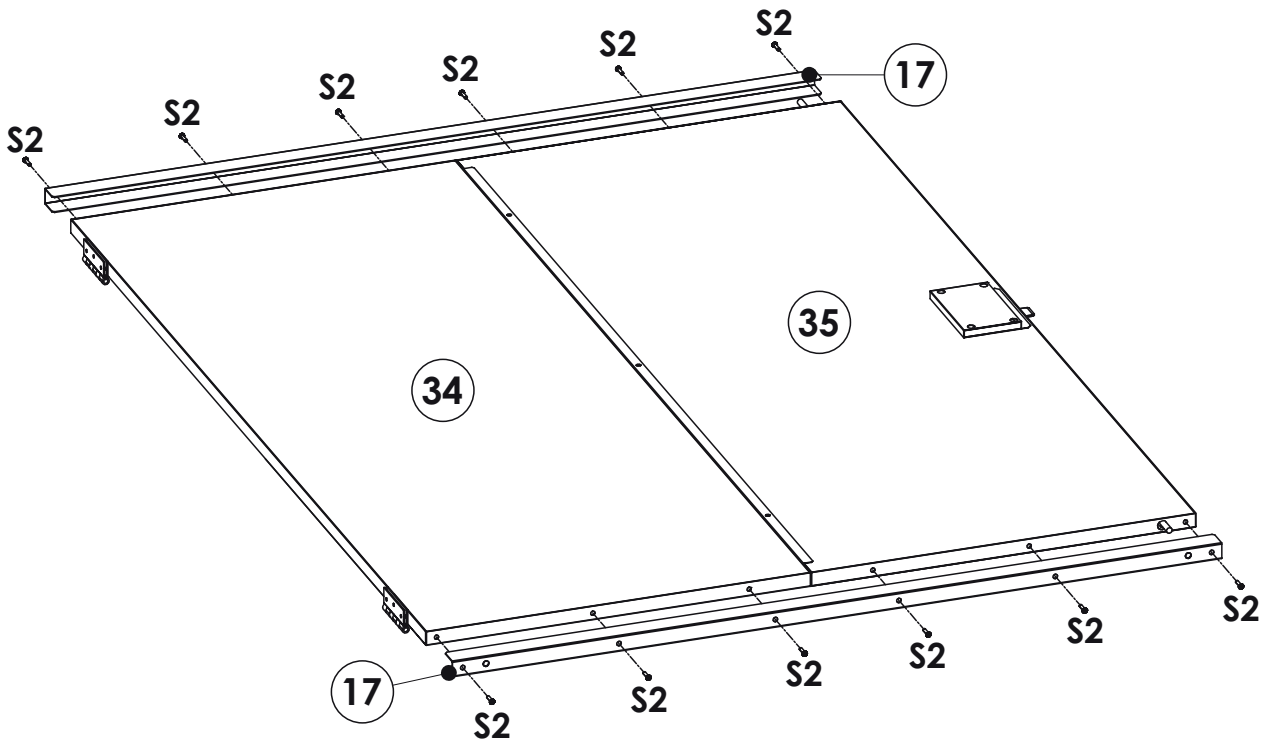
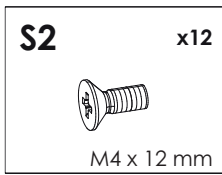

46

