

Abri de jardin métallique/ metal tool shed

weka

Référence : 70219090600 - 70229290700

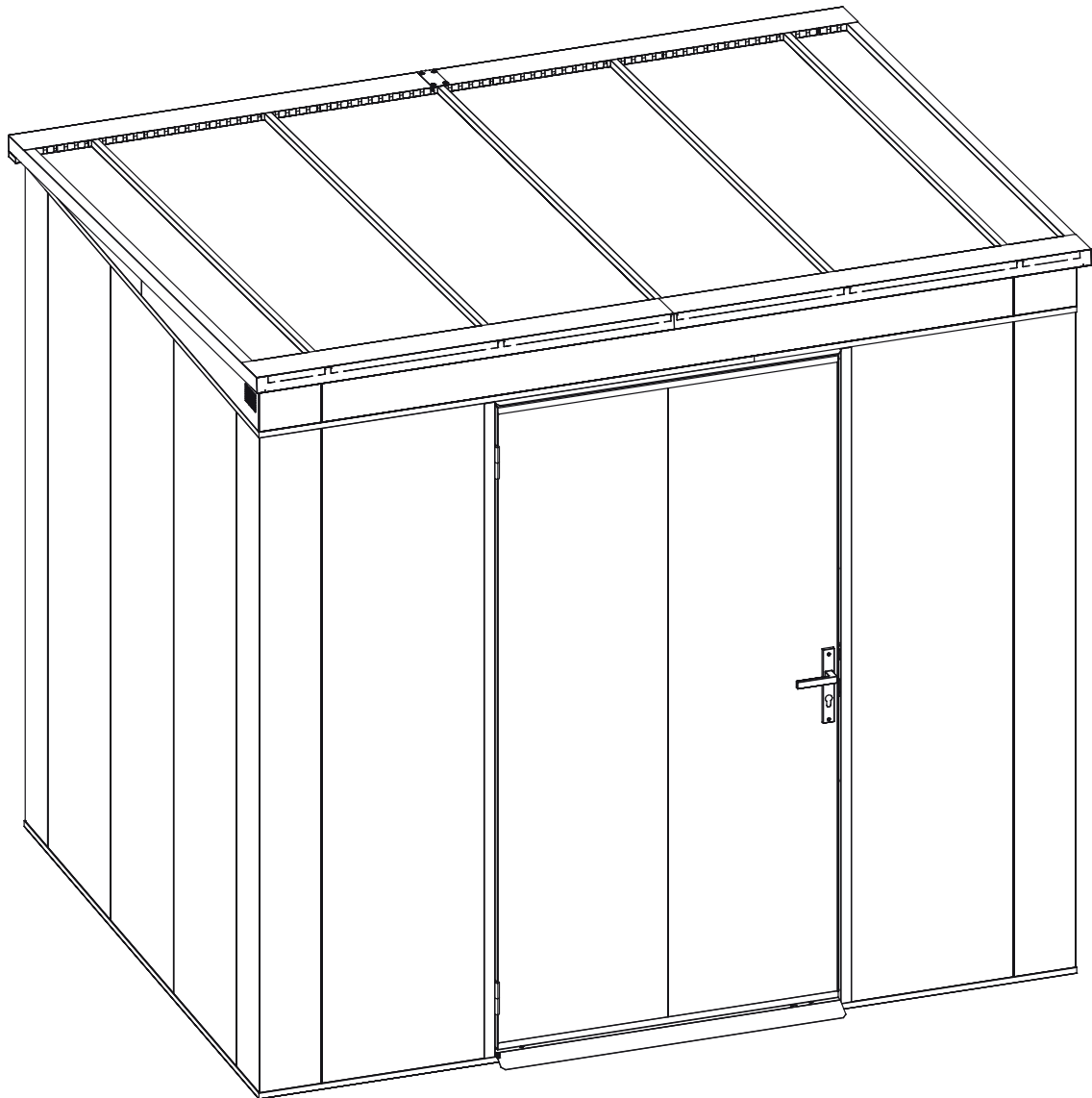

**Instructions de montage/
Assembly instructions**

weka Holzbau GmbH
Postfach 20 02 04
D-17013 Neubrandenburg

Vous pouvez nous joindre :
Du lundi au vendredi, de 8h30 à 18h00

www.weka-holzbau.com

+49 (0)395/42908-0

Sicherheitshinweise/ safety instructions

Les remarques s'appliquent aux articles suivants/The information applies to the following items: 70219090600, 70219090700, 70219140600, 70219140700, 70219190600, 70219190700, 70224140600, 70224140700, 70224190600, 70224190700, 70224240600, 70224240700, 70229140600, 70229140700, 70229190600, 70229190700, 70229290600, 70229290700

1. Équipe de montage/Assembly Team

FR: Le montage doit toujours être effectué par deux personnes.

EN: Assembly must always be carried out by two people.

2. Équipement de protection et support/ Protective Equipment & Surface Protection

FR: Portez des gants de travail pendant le montage.

Utilisez un support approprié pour éviter les rayures.

EN: Wear work gloves during assembly.

Use a suitable surface protector to avoid scratches.

3. Pièces endommagée / Damaged Parts

FR: N'installez pas de pièces endommagées.

Les dommages constatés doivent nous être signalés à l'aide de photos explicites. Les pièces déjà montées sont considérées comme acceptées.

EN: Do not install any damaged components.

Report all identified damage to us with meaningful photos.

Parts that have already been installed are considered accepted.

4. Assemblages vissés/ Screw Connections

FR: Ne serrez tous les assemblages vissés qu'une fois le montage terminé.

EN: Tighten all screw connections only after the assembly has been fully completed.

5. Stabilité et intempéries/ Stability & Weather Conditions

FR: Veillez à ce que l'ancrage au sol soit résistant aux tempêtes.

N'installez pas le produit par temps venteux.

EN: Ensure the product is securely anchored to the ground to withstand strong winds.

Do not assemble the product in windy conditions.

6. Sécurité des enfants et arêtes vives/ Child Safety and Sharp Edges

FR: Pendant le montage, tenez les petites pièces et les matériaux d'emballage hors de portée des enfants.

Les composants peuvent présenter des arêtes vives ou des parties saillantes.

Faites attention à cela pendant le montage et l'utilisation quotidienne.

EN: Keep small parts and packaging materials away from children during assembly.

Components may have sharp edges or protruding parts.

Pay attention to this during assembly and during everyday use

7. Sécurité à des températures élevées

FR: en été, des températures très élevées peuvent être atteintes à l'intérieur.

EN: During summer, very high temperatures may occur inside the house.

8. Couvertures/ Covers

FR: n'utilisez pas de housses ou de coques pour le produit.

EN: Do not use covers or tarpaulins on the product.

9. Sol / Ground Surface

FR : le produit ne doit être monté que sur un support adapté, solide et plat..

EN: The product may only be assembled on a suitable, solid, and level surface.

10. Transport/ Transport

FR: le produit n'est pas adapté au transport une fois monté. Il doit être monté sur son emplacement définitif afin d'éviter tout dommage lié au transport.

EN: The product is not suitable for transport in assembled condition.

It must be assembled at its final installation location to avoid transport damage.

11. Remarque concernant la garantie/ Warranty Notice

FR : veuillez noter que toute modification ou altération du produit entraîne l'annulation de la garantie.

EN: Please note – Any changes or modifications to the product will void the warranty.

Entretien et maintenance / Care and Maintenance

1. Produits chimiques et nettoyage / Chemicals & Cleaning

FR : ne stockez pas de produits chimiques agressifs tels que du chlore ou du sel de déneigement dans ou sur le produit.

N'utilisez pas de produits nettoyants abrasifs. Éliminez la crème solaire et autres crèmes à l'eau et au savon !

EN: Do not store aggressive chemicals such as chlorine or road salt in or near the product.

Do not use abrasive cleaning agents. Remove sunscreen and other creams with soap and water!

2. Neige et charge de neige/ Snow & Snow load

FR : Enlevez régulièrement la neige du toit afin de ne pas dépasser la limite maximale de charge de neige et d'éviter tout risque d'effondrement.

EN: Regularly remove snow from the roof to avoid exceeding the maximum snow load limit and prevent the risk of collapse.

3. Serrure/ Lock

FR : Huilez la serrure une fois par an !

EN: Oil the lock annually!

4. Assemblages vissés/ Screw Connections

FR : Contrôlez régulièrement les assemblages vissés !

EN: Check screw connections regularly!



a = b

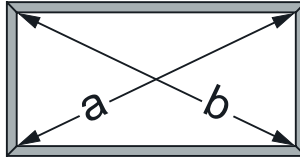

A

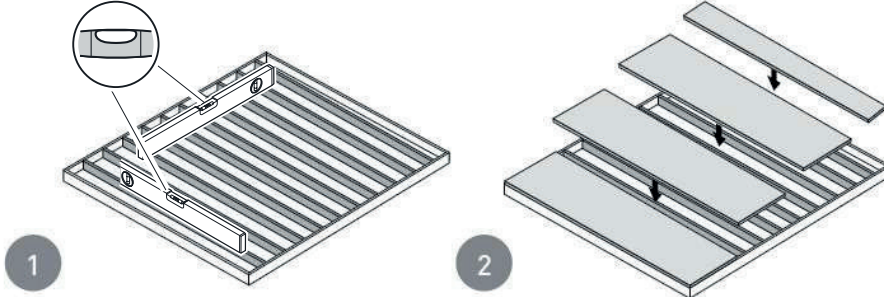

B

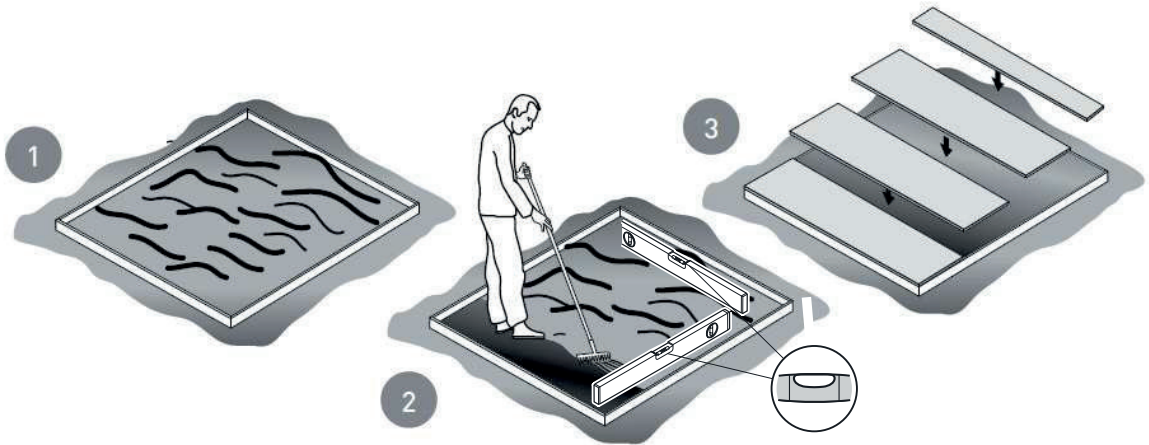

C

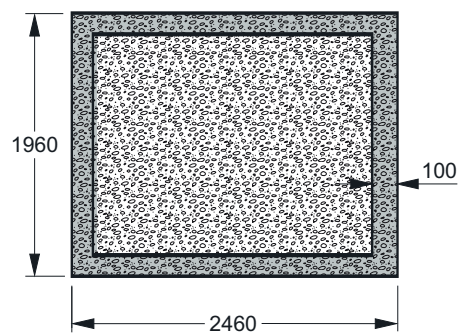
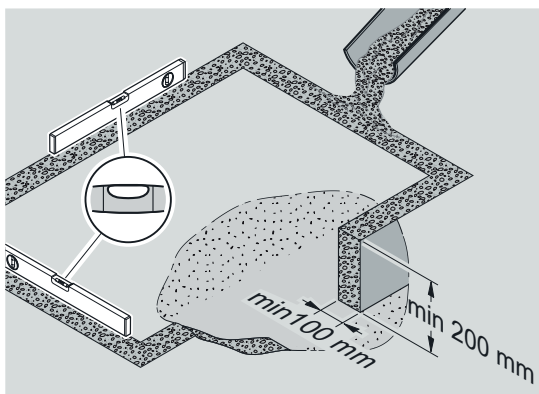

1. Aperçu des pièces/ Summary of Components

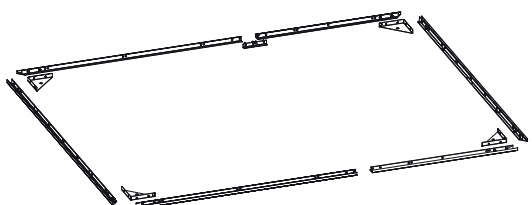
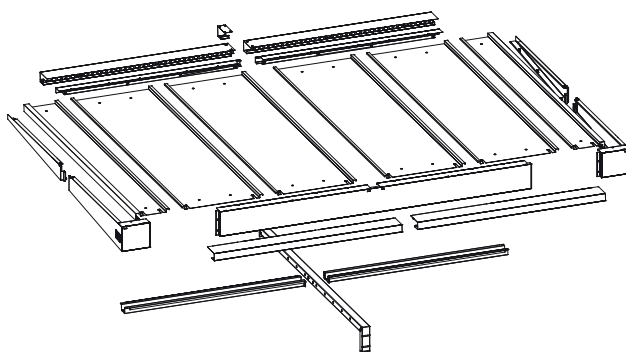
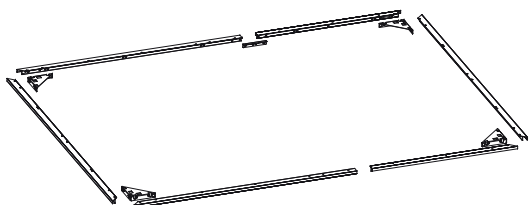
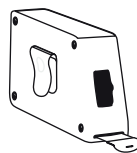
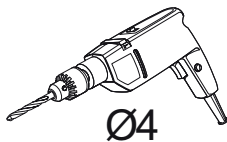
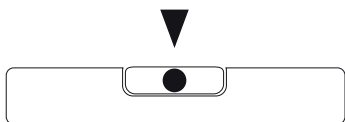
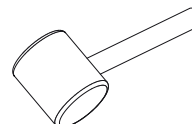
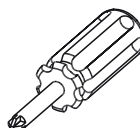
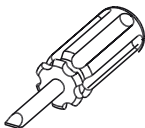
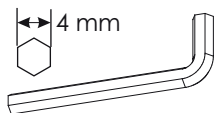
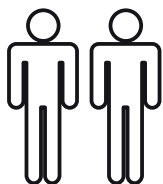

A.1

C.1

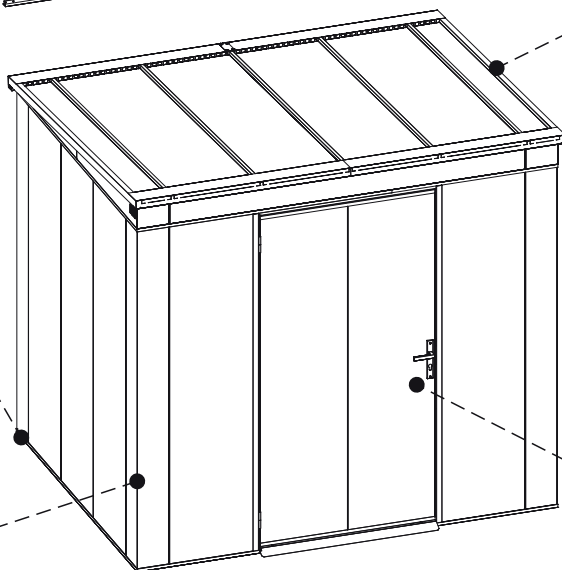

B.1

D.1

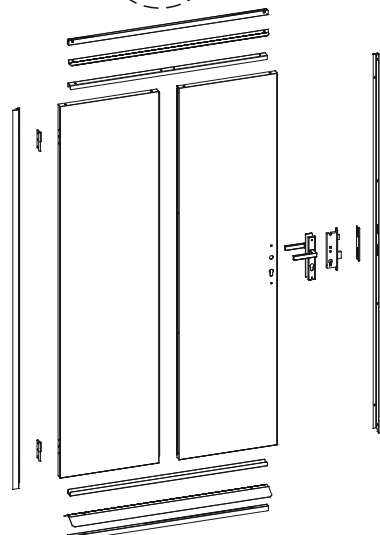
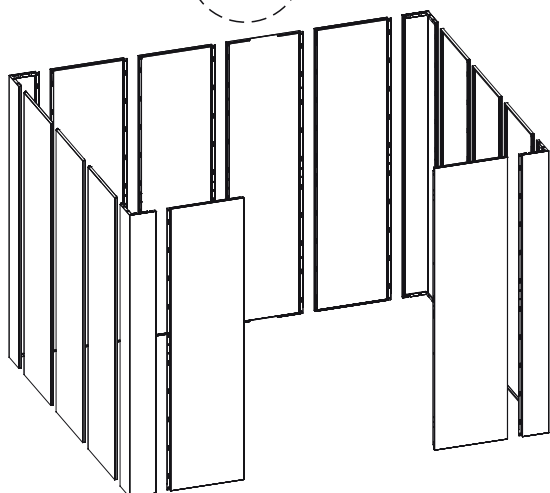

Aperçu des pièces / Summary of Components

A1

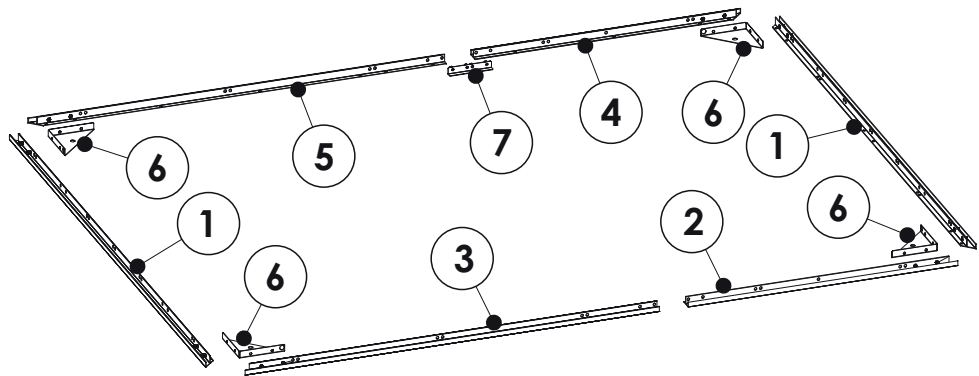
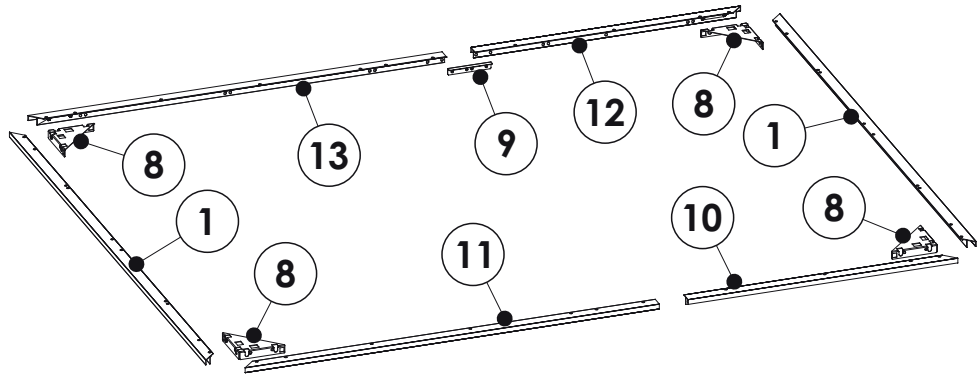

B1

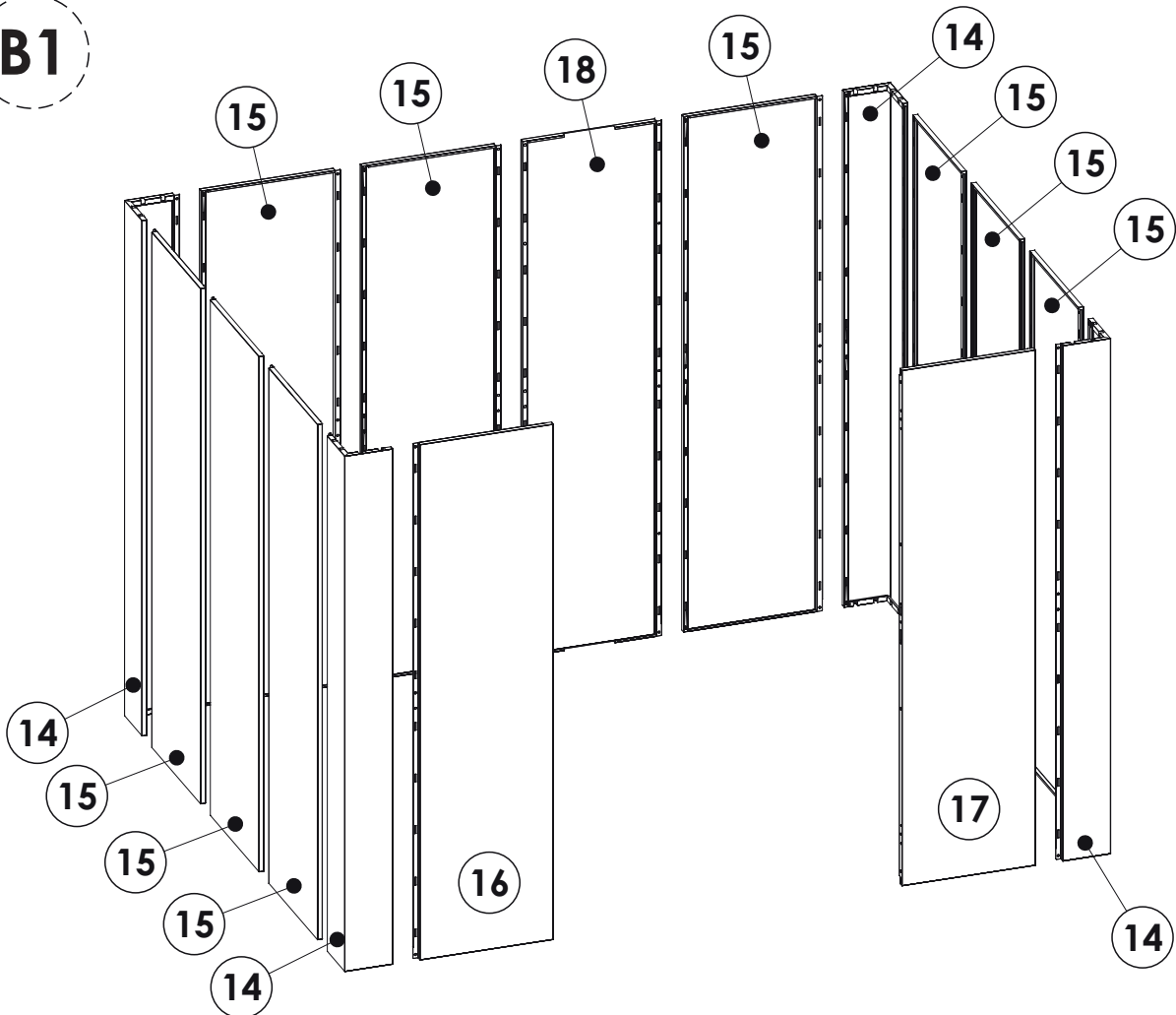

Aperçu des pièces/ Summary of Components



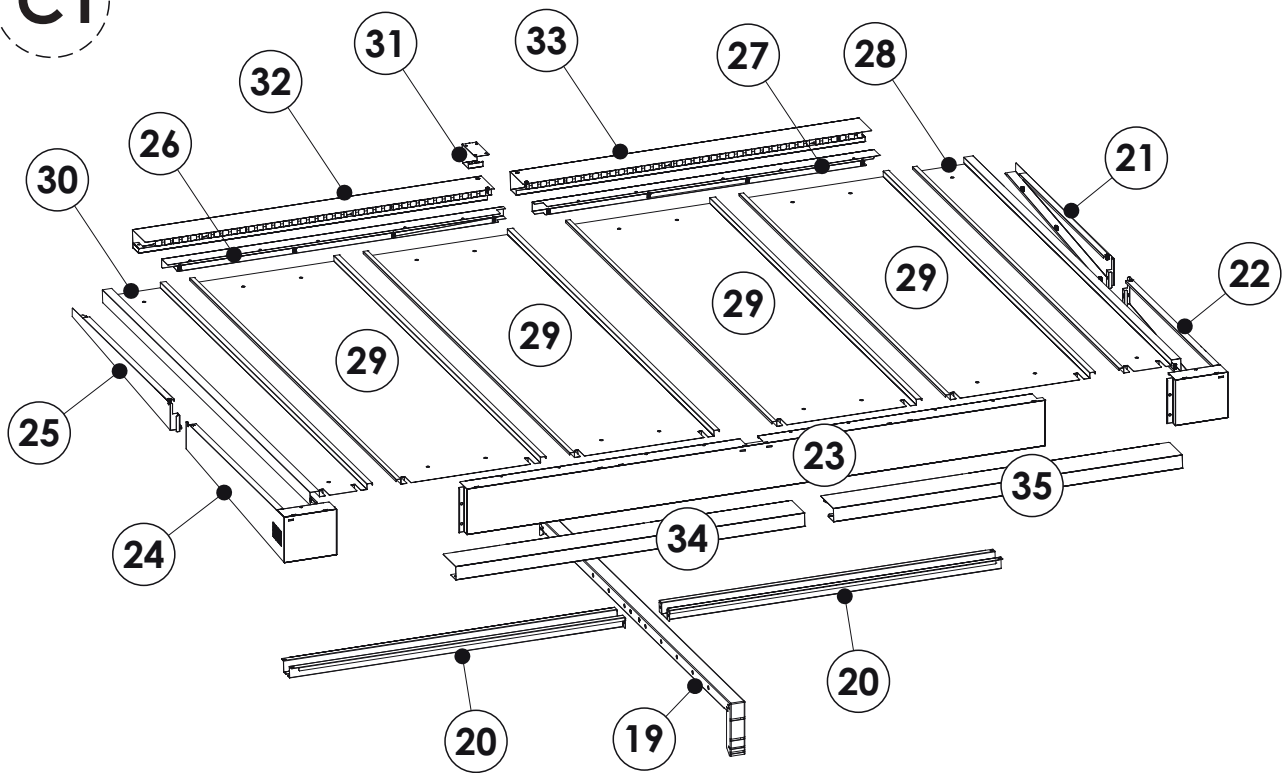

C1

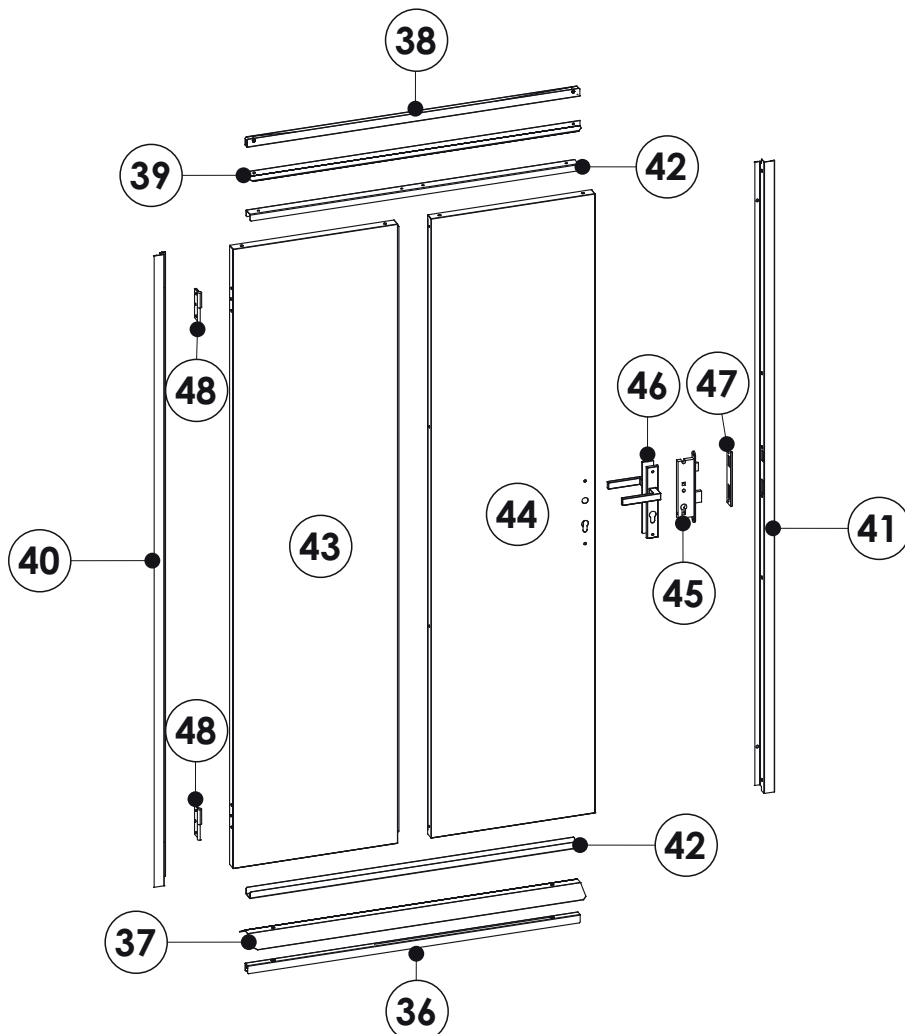

D1

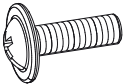

Aperçu des pièces / Summary of Components

S1 x177  M6 x 16 mm	S2 x14  M5 x 10 mm	S3 x20  M4 x 10 mm	S4 x9  M6 x 12 mm	S5 x2  x2
--	---	---	--	--

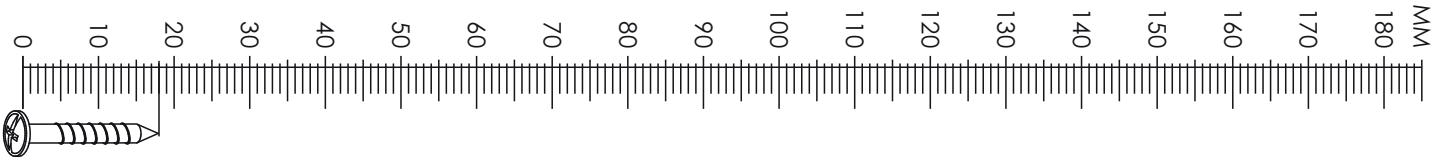

1. Début de l'installation / Start of installation

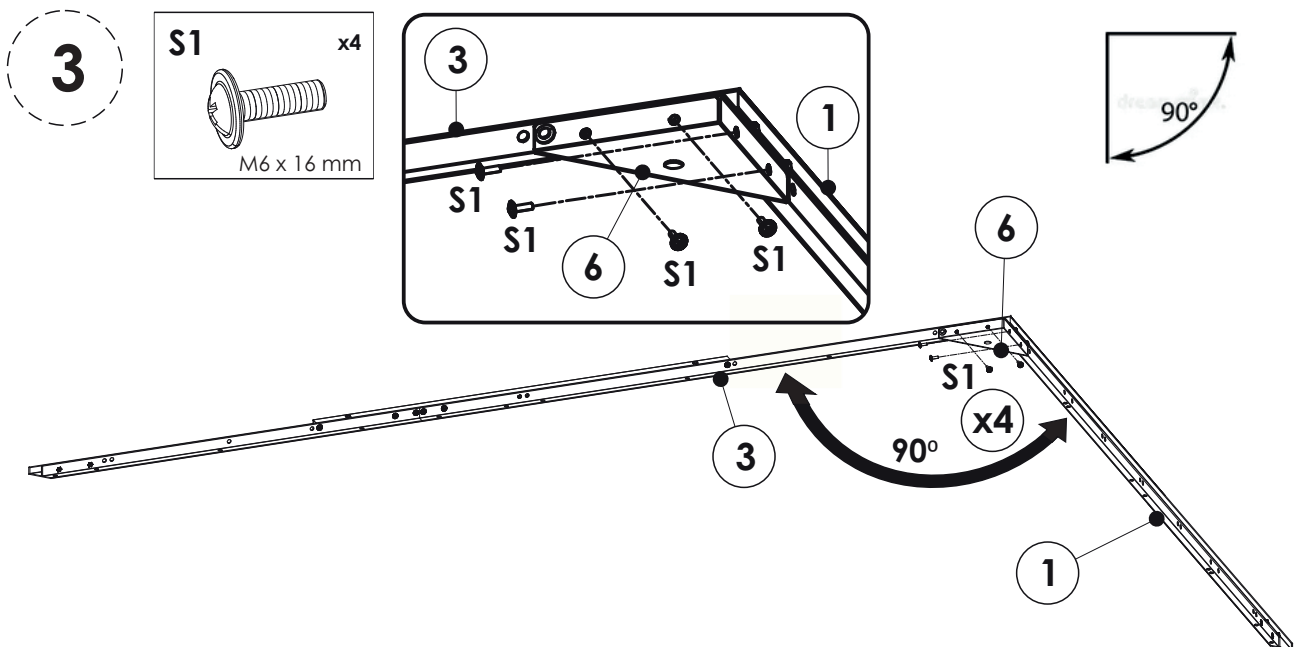
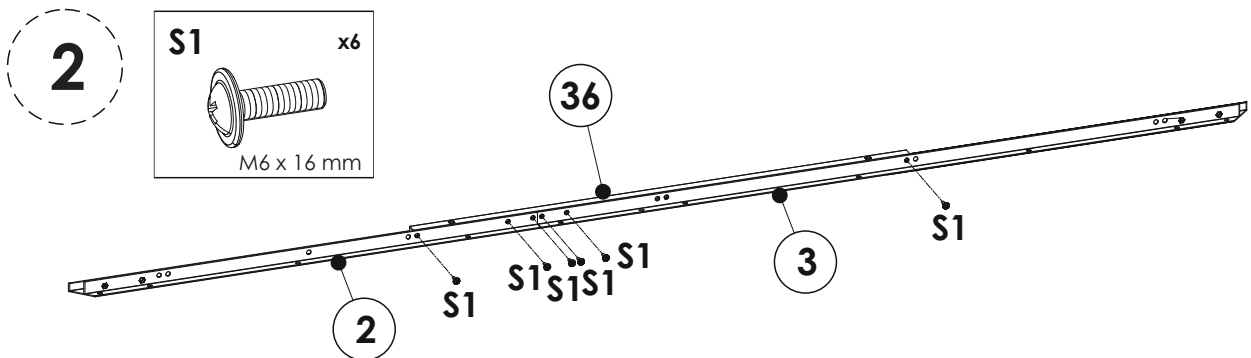
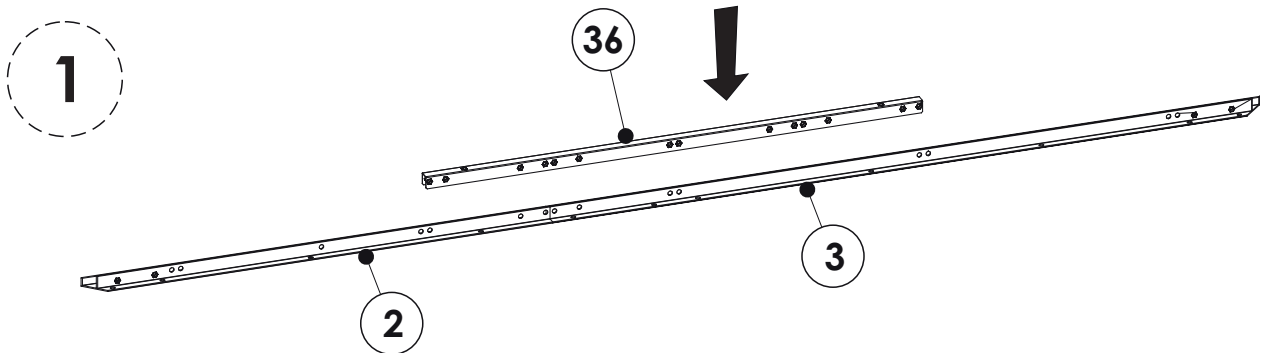

4

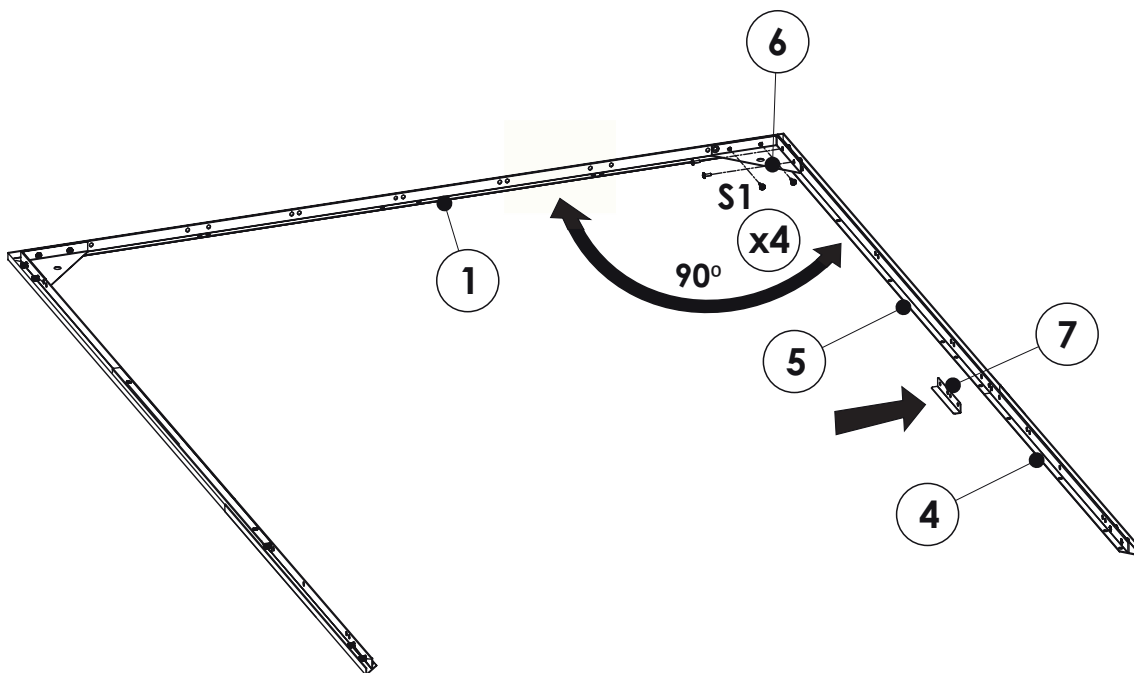
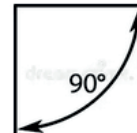
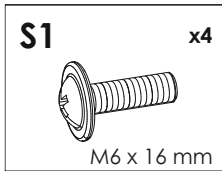

5

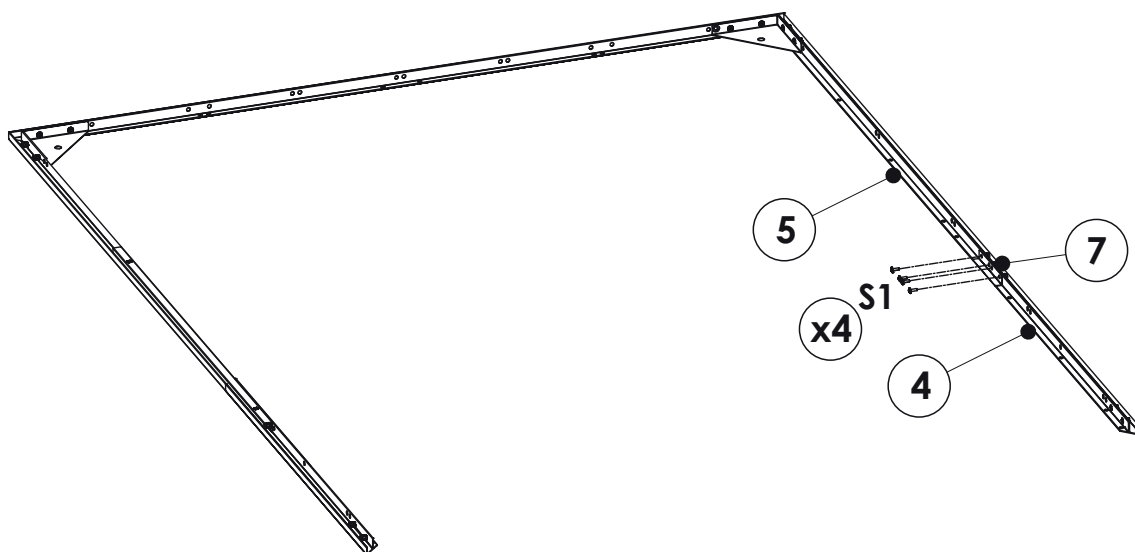
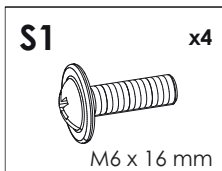

6

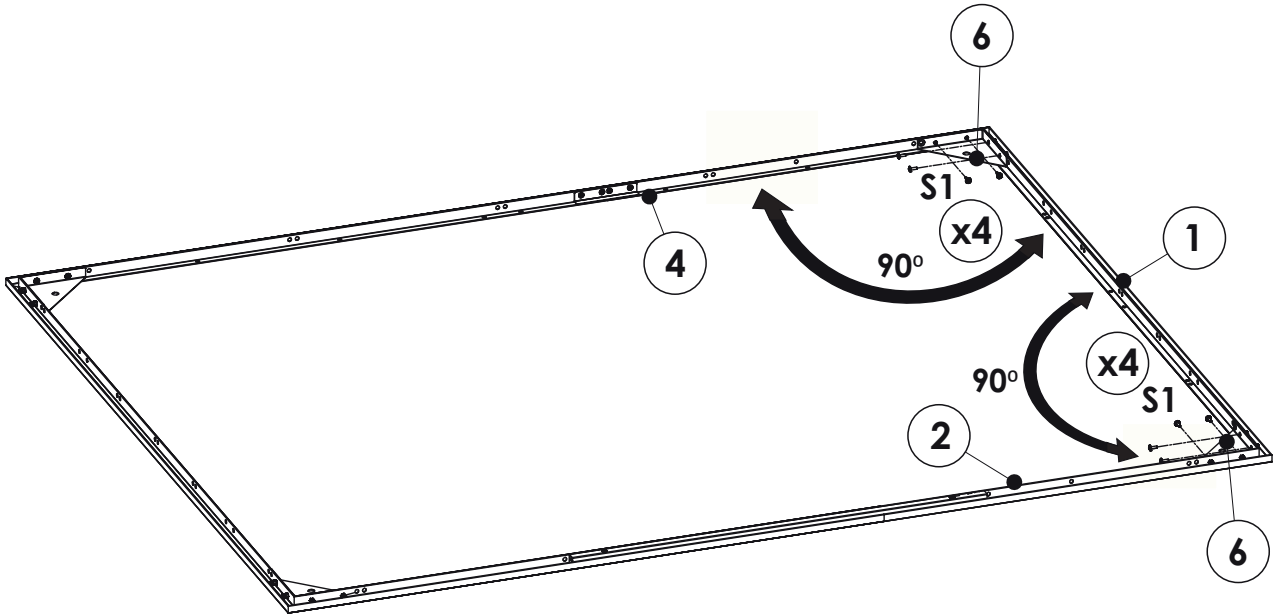
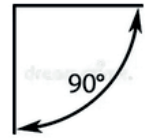
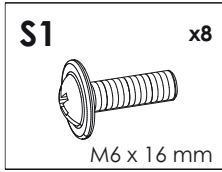

7

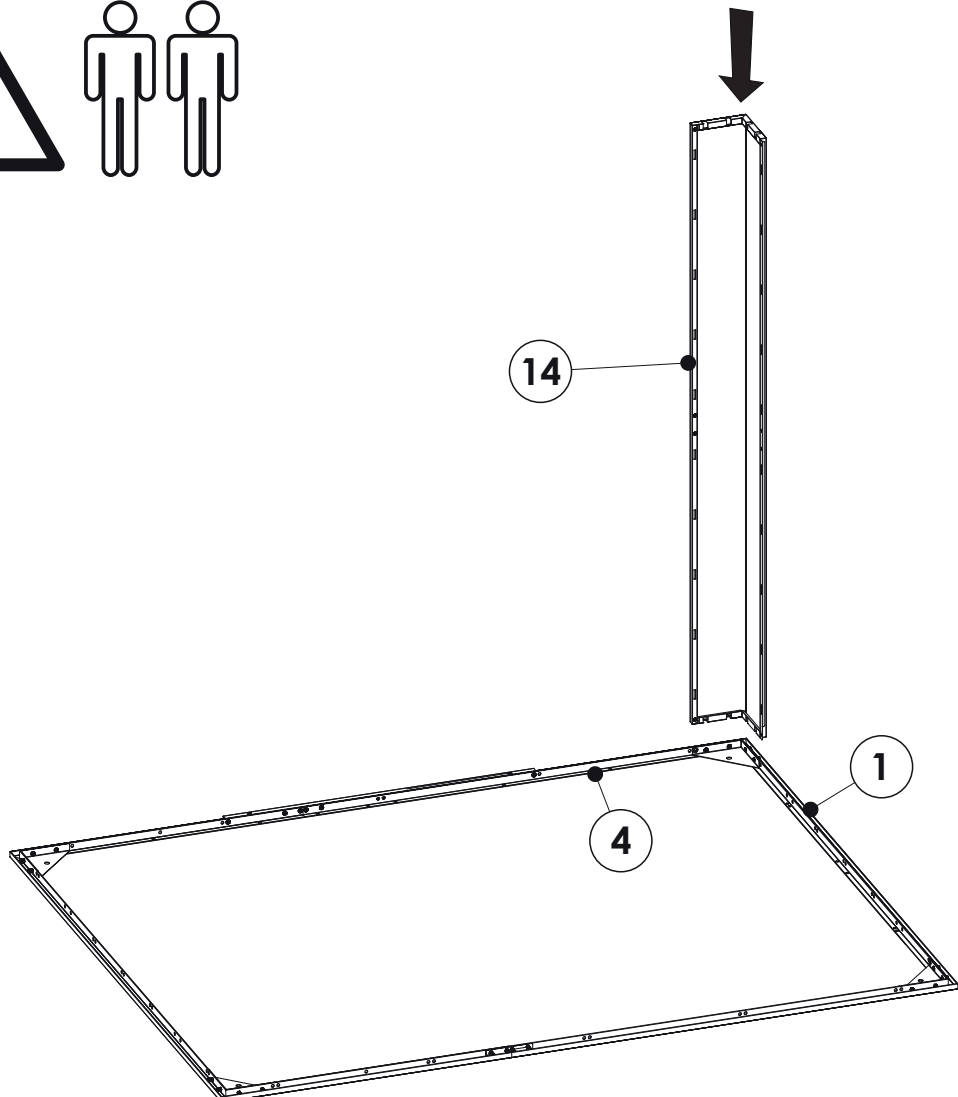
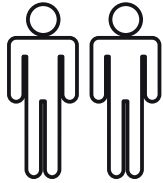

8

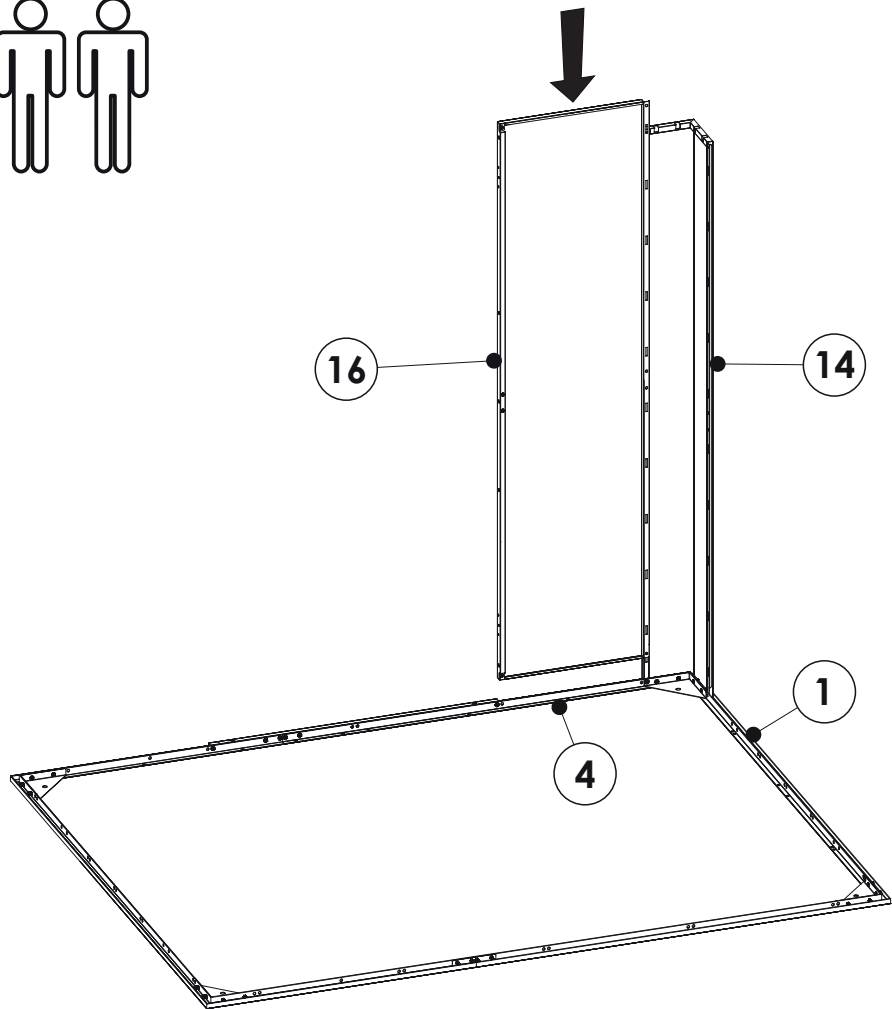
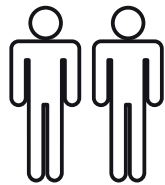

9

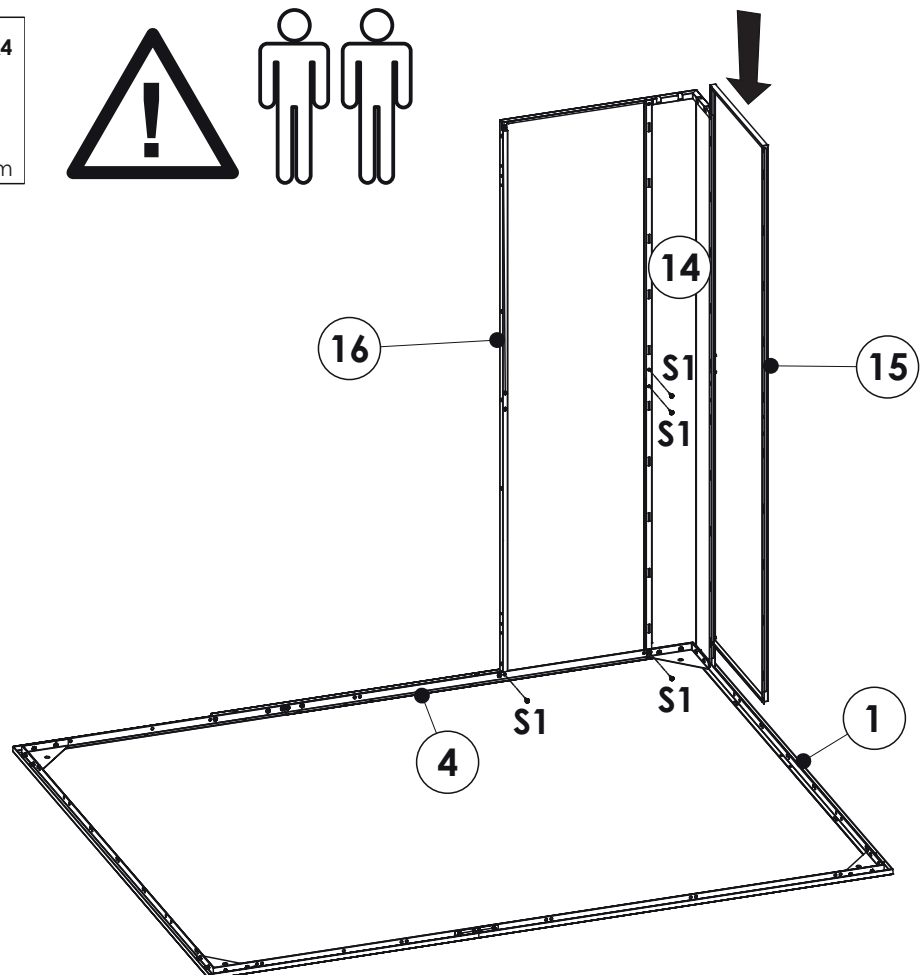
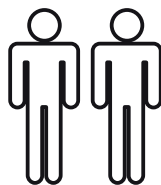
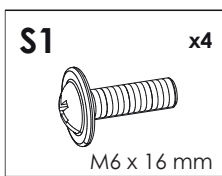

10

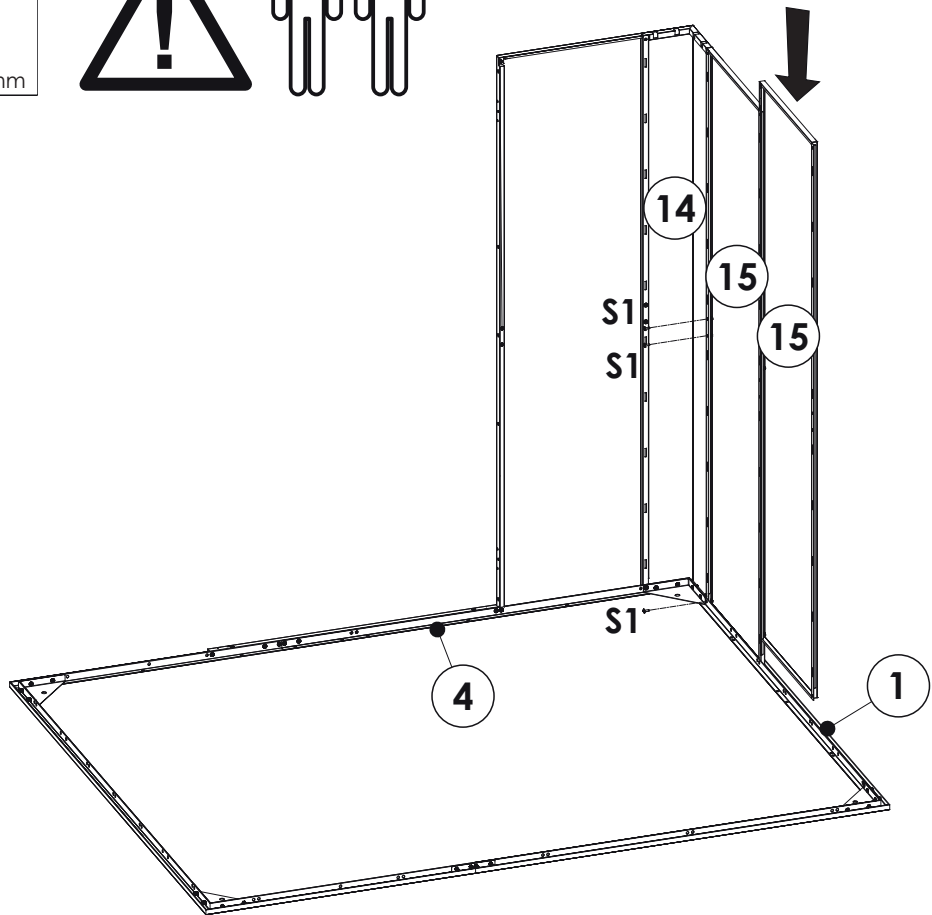
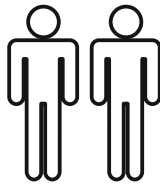
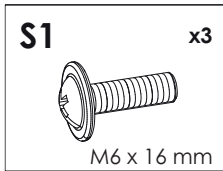

11

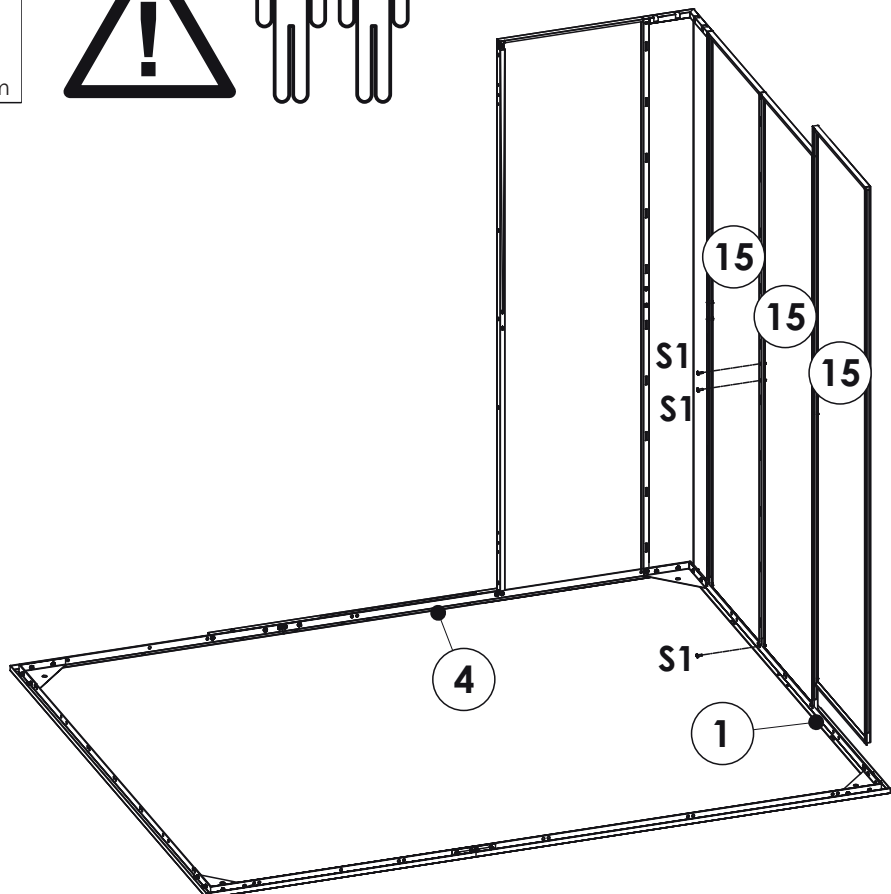
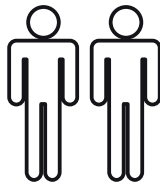
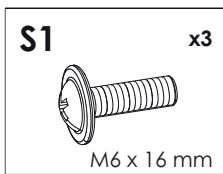

12

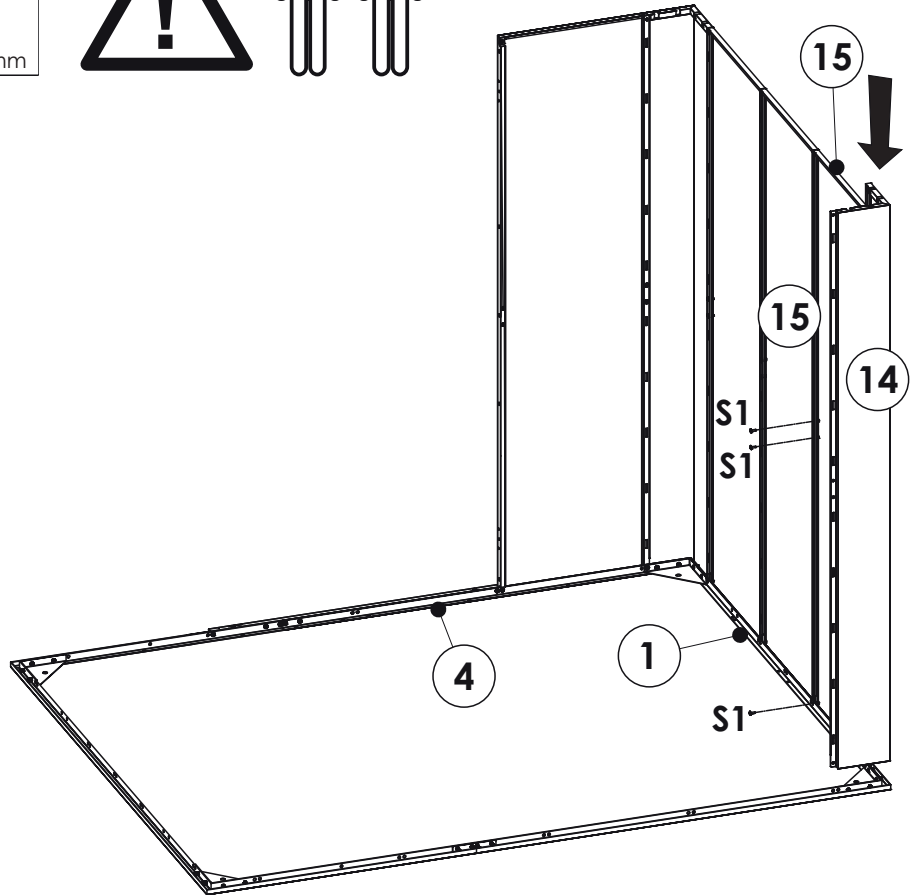
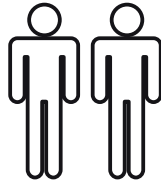
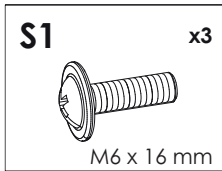

13

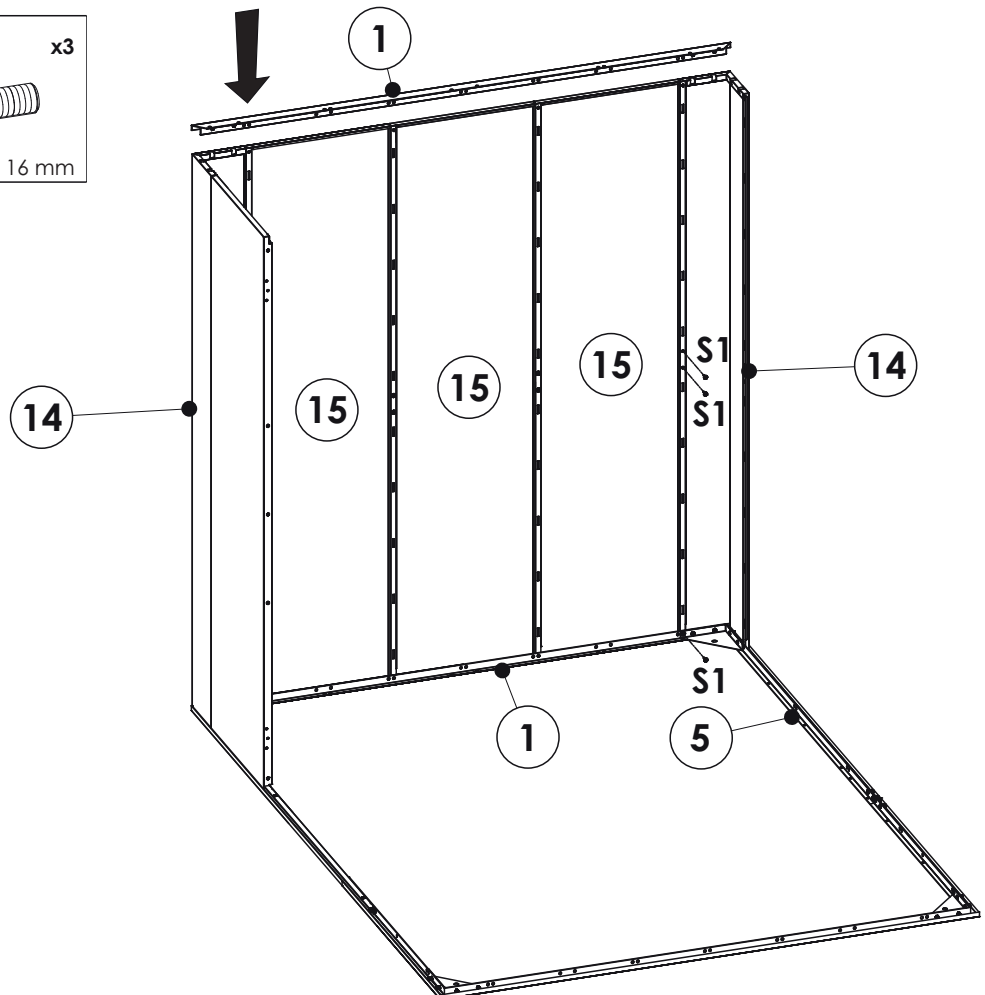
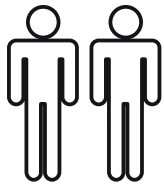
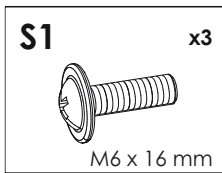

14

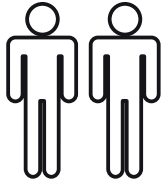
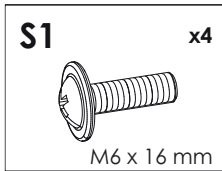

14

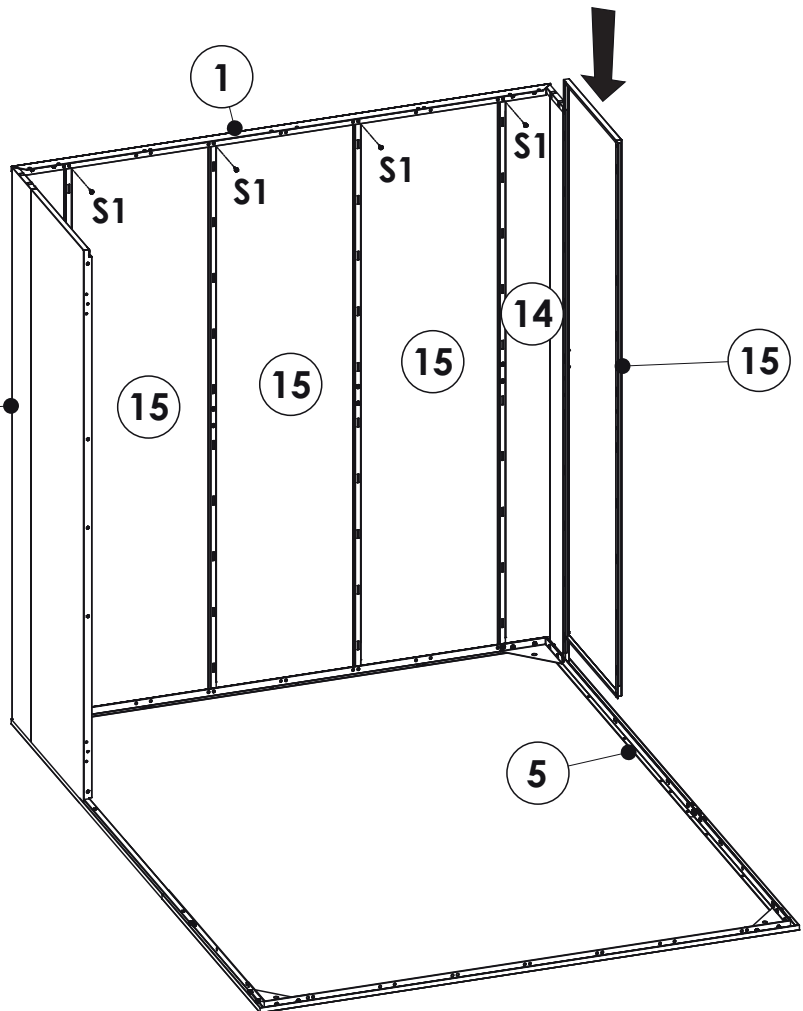

15

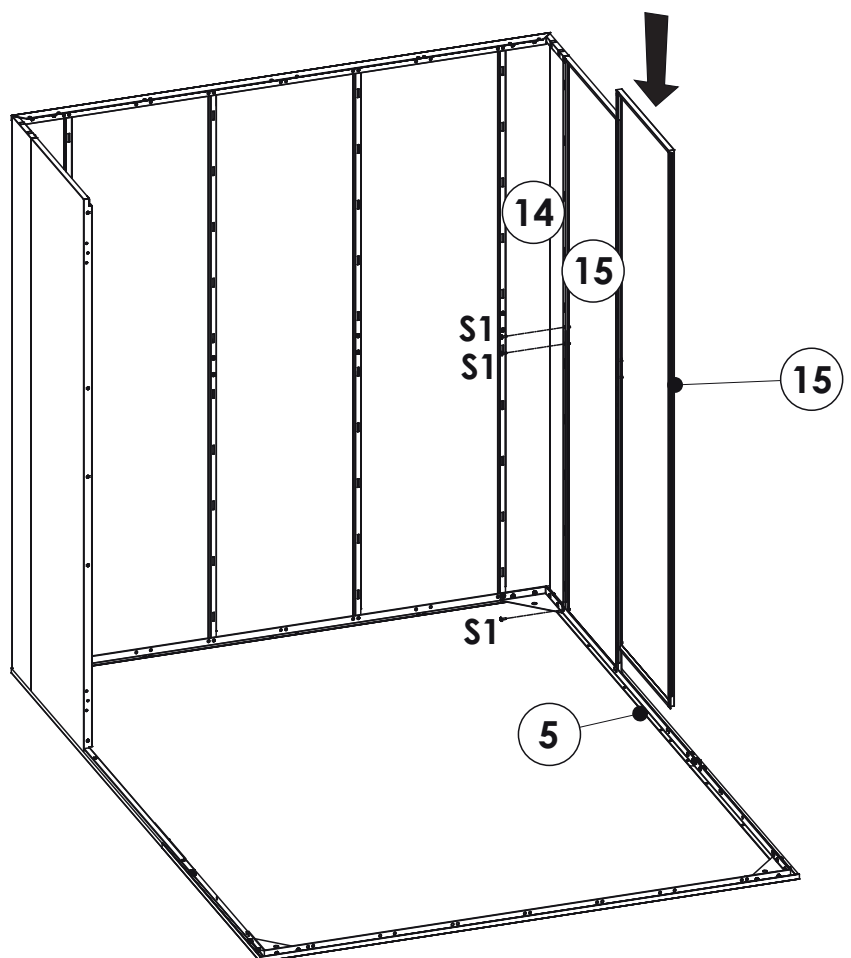
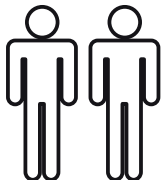
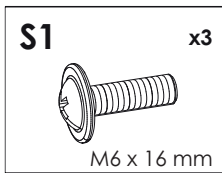

16

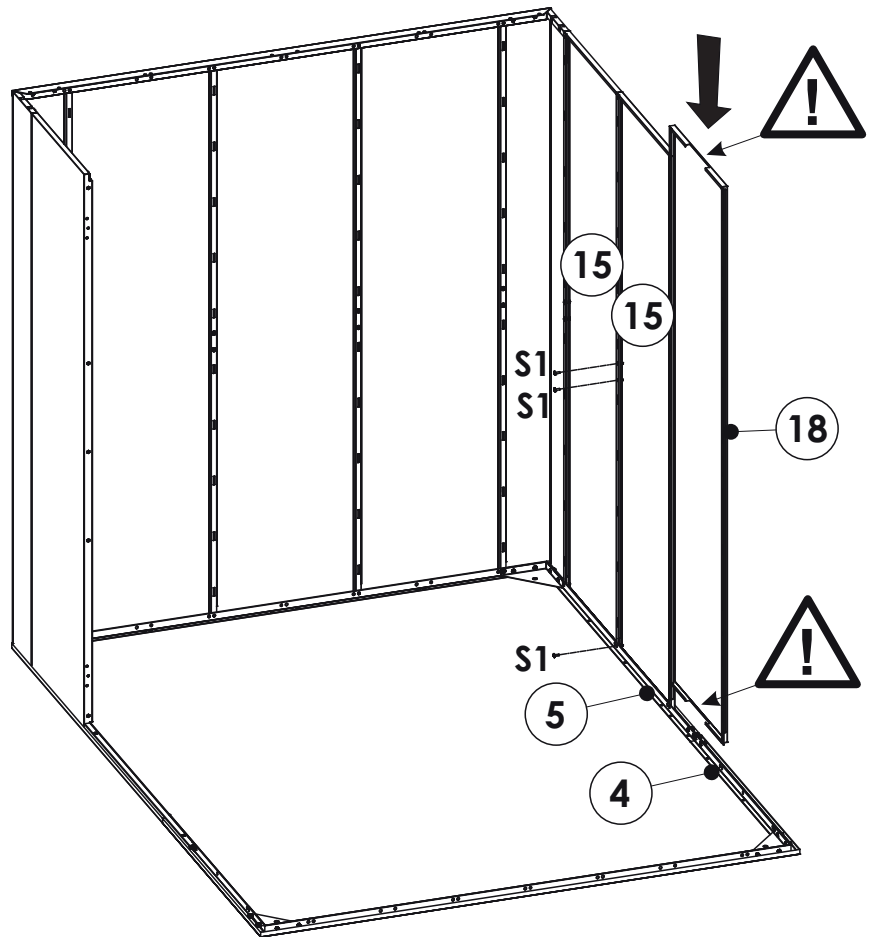
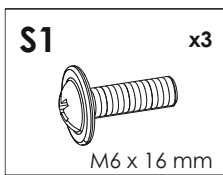

17

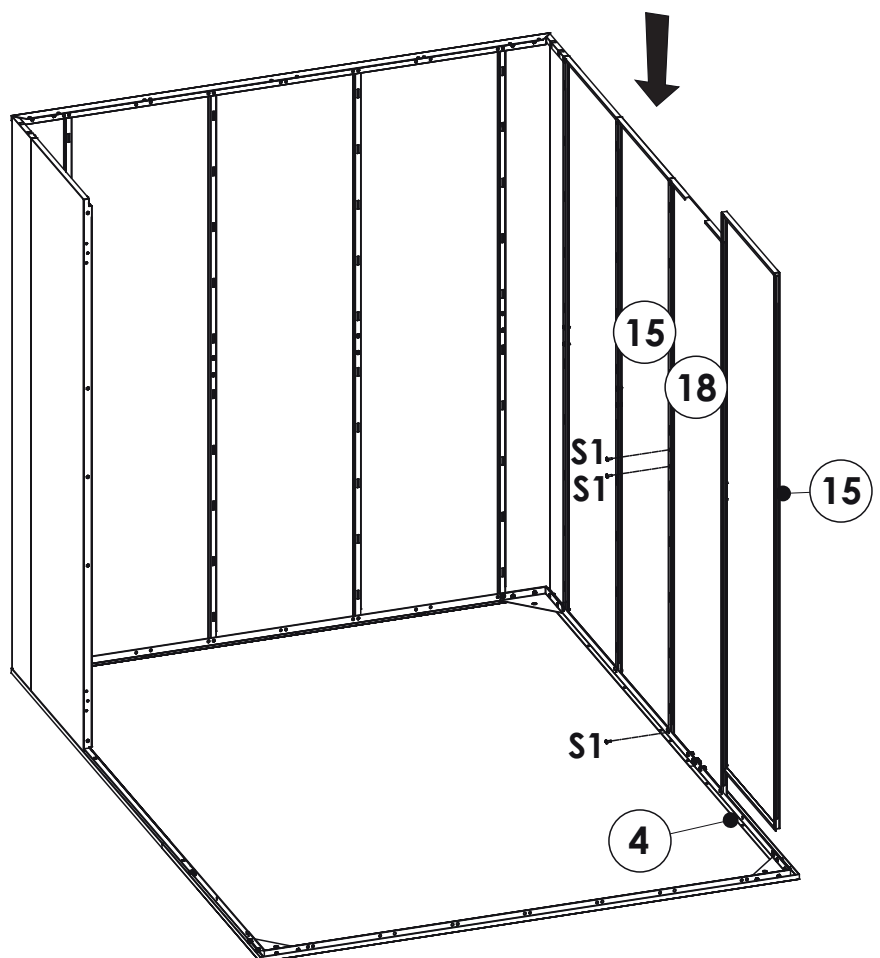
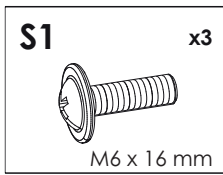

18

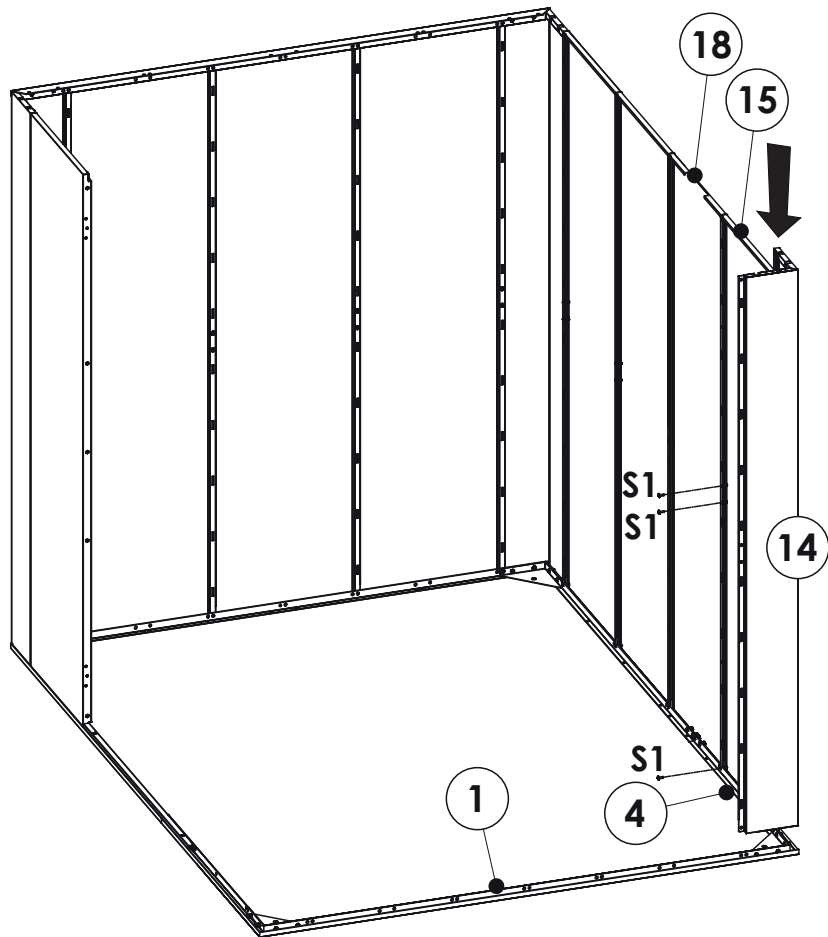
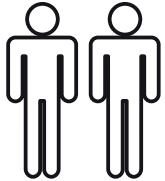
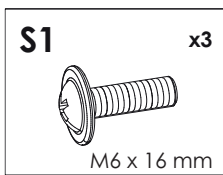

19

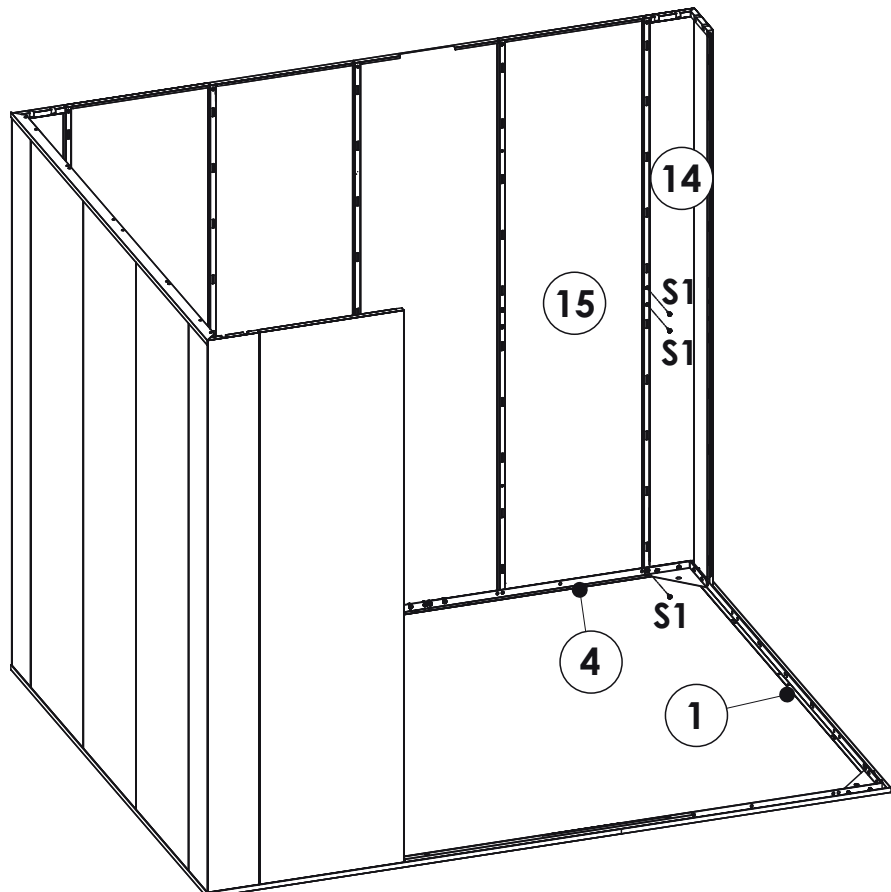
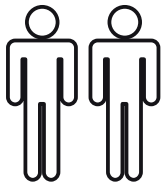
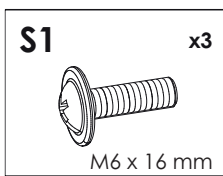

20

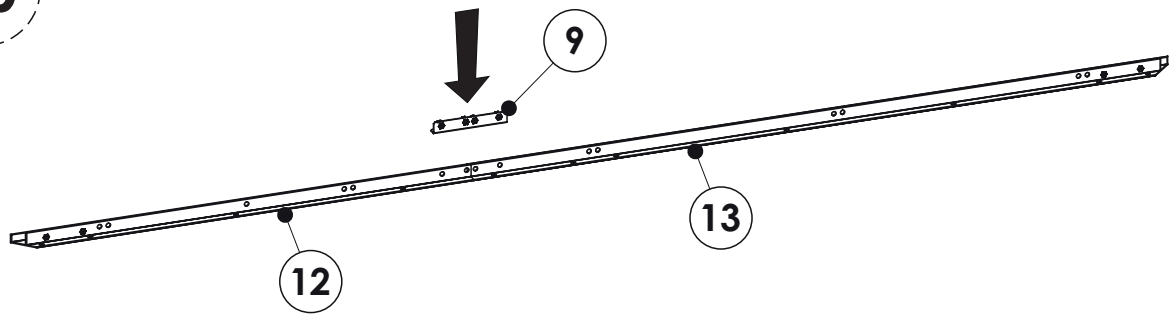

21

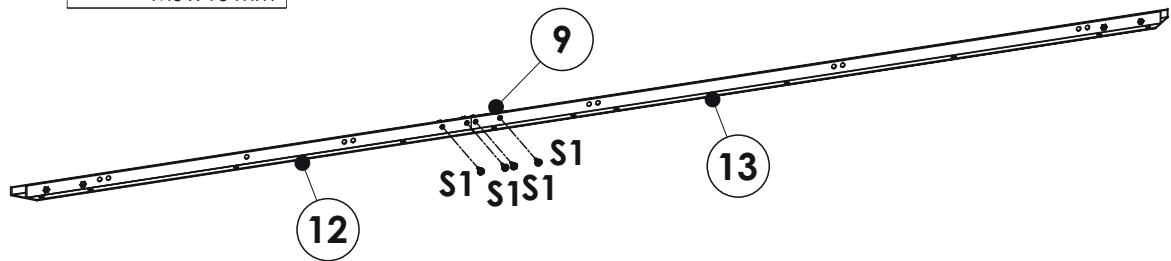
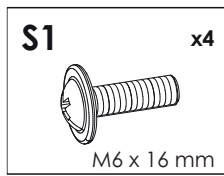

22

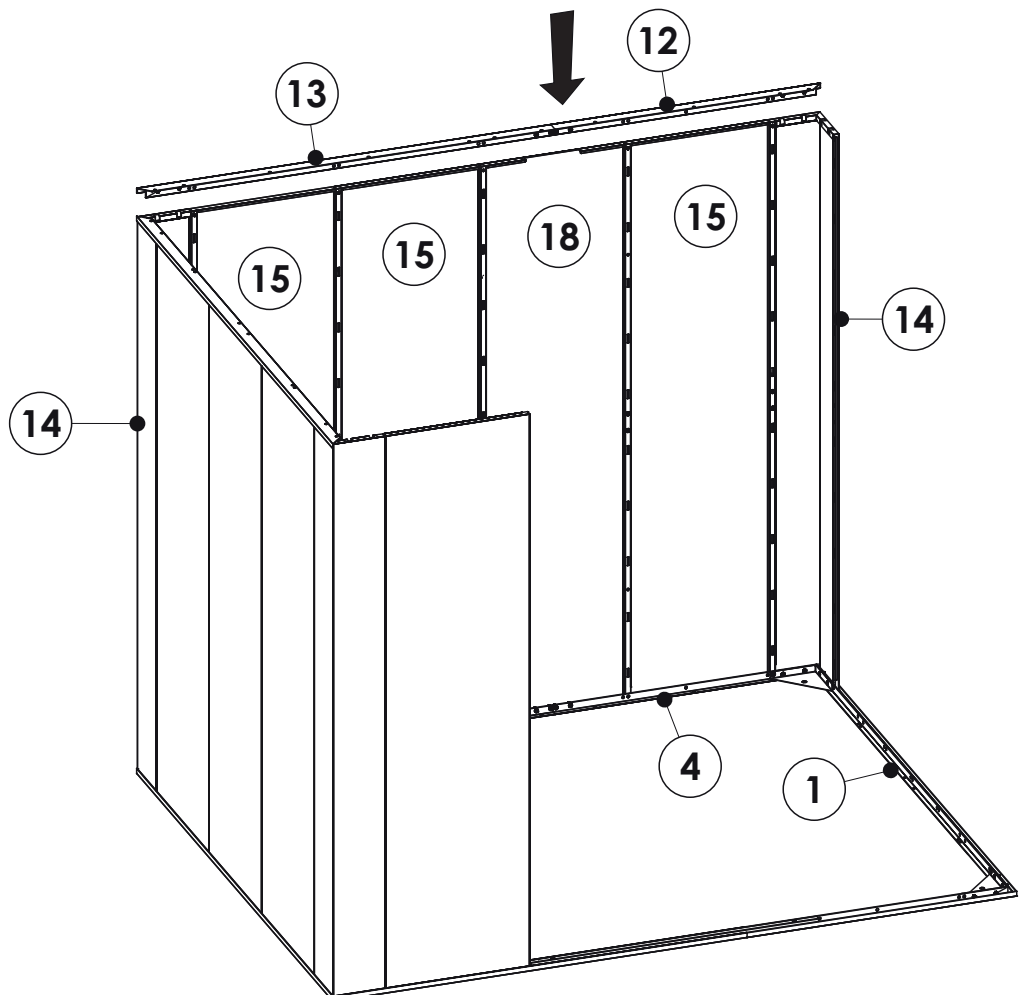
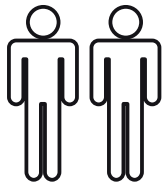

23

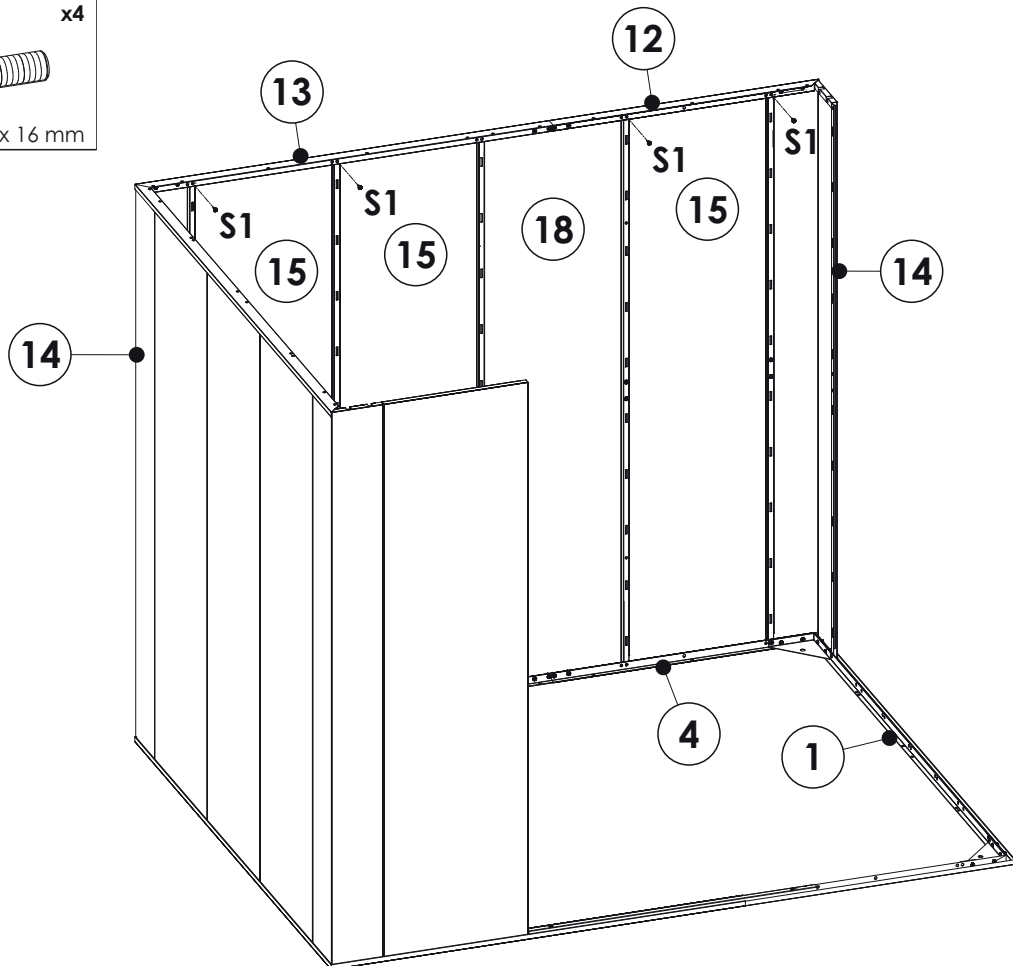
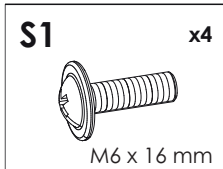

24

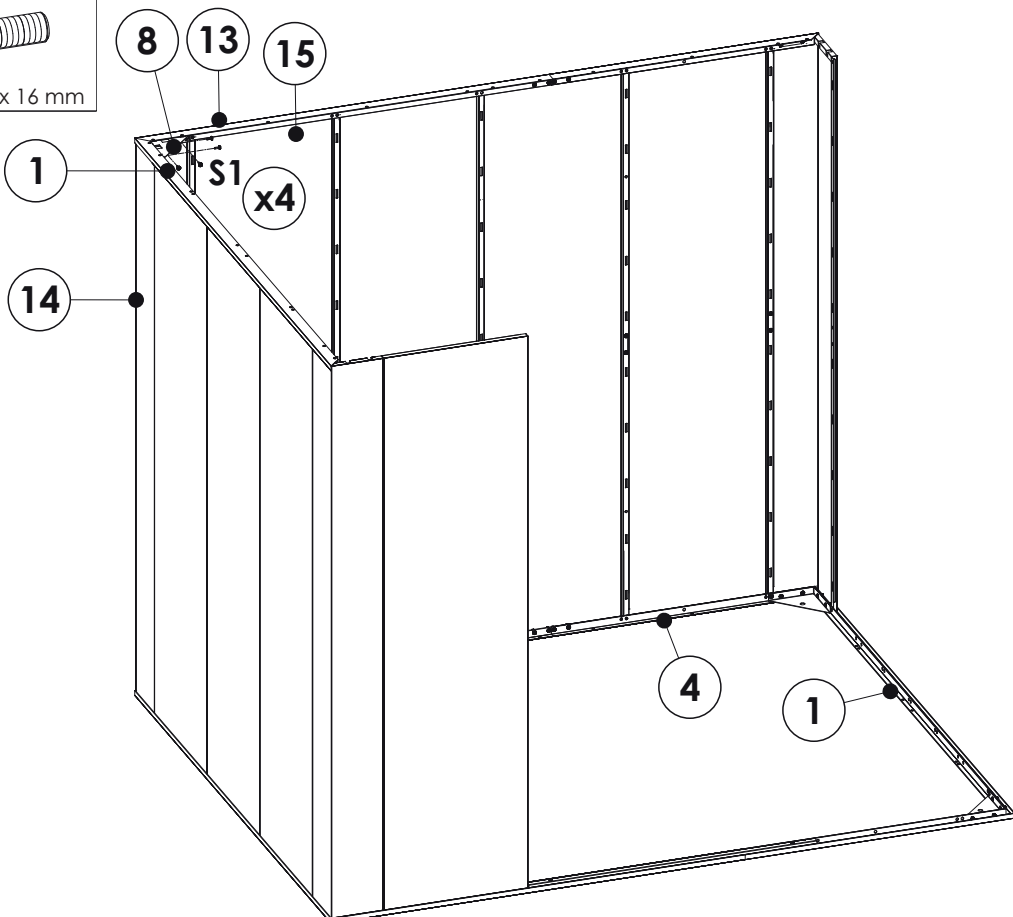
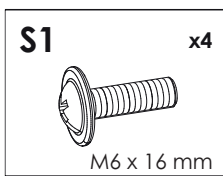

25

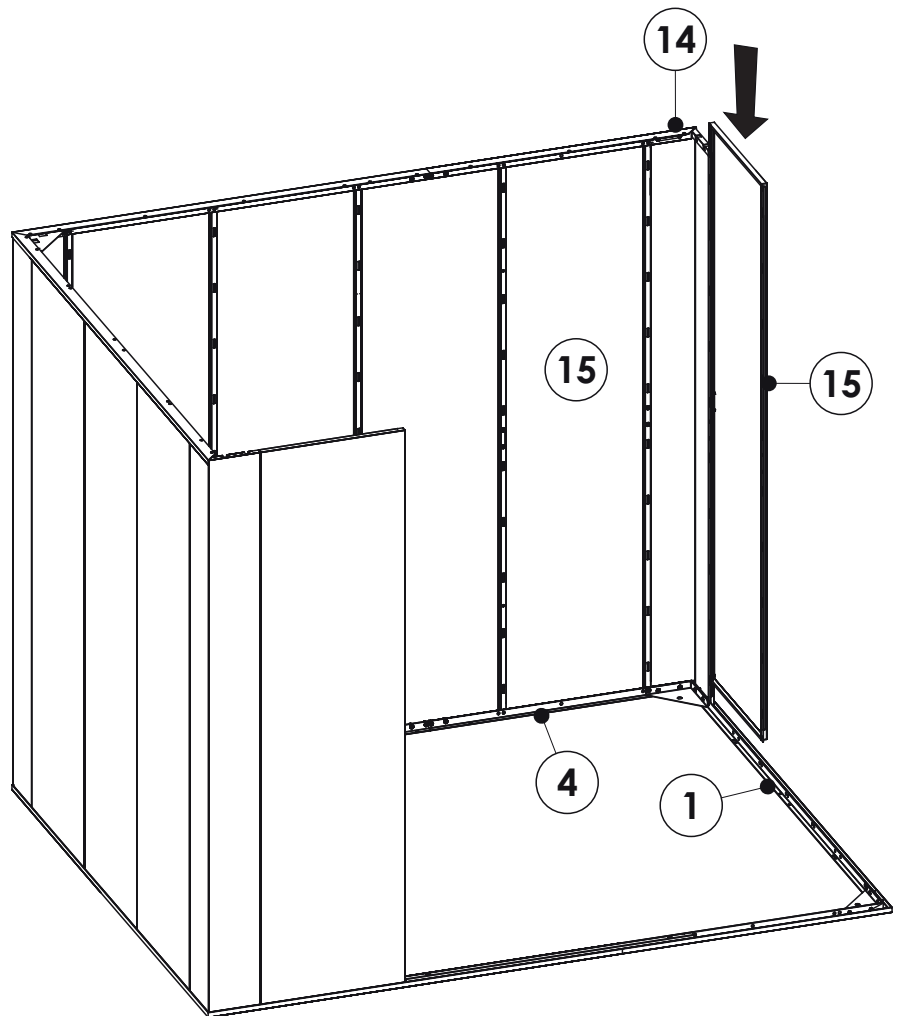
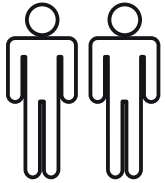

26

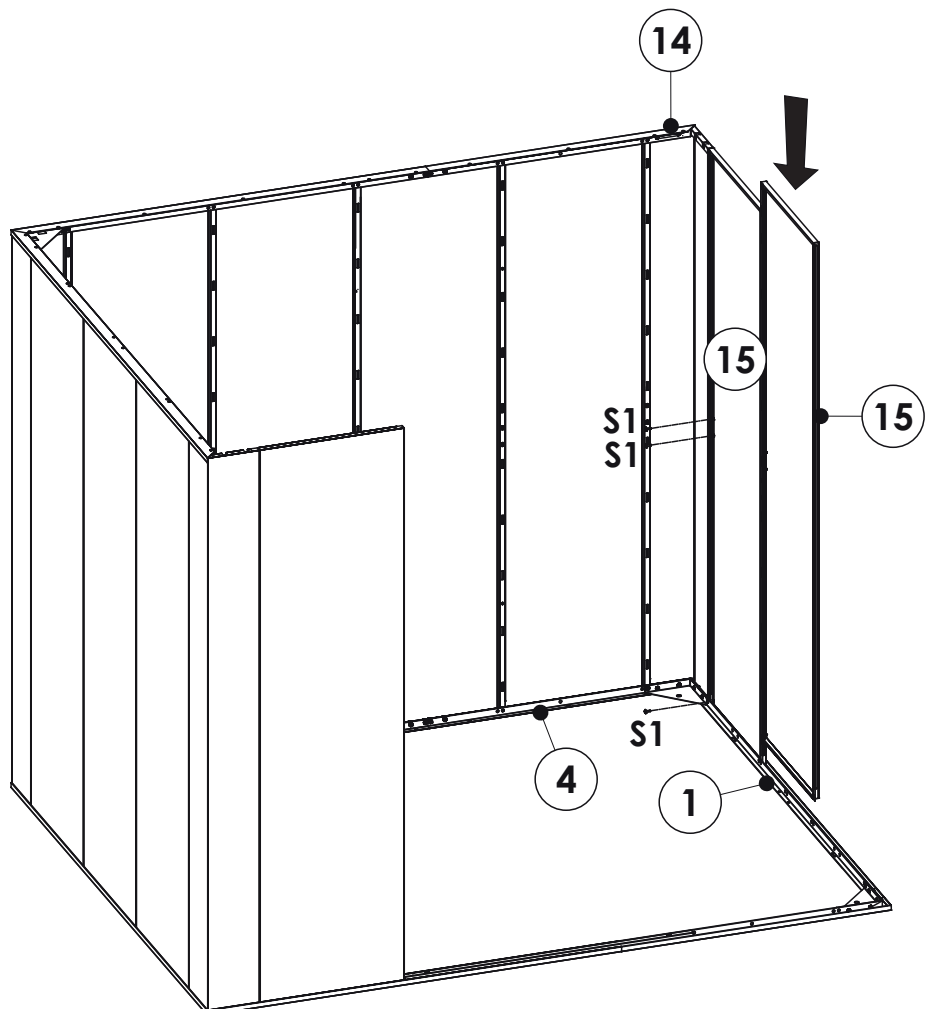
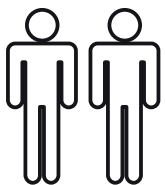
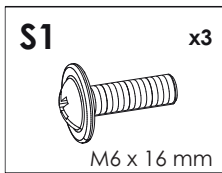

27

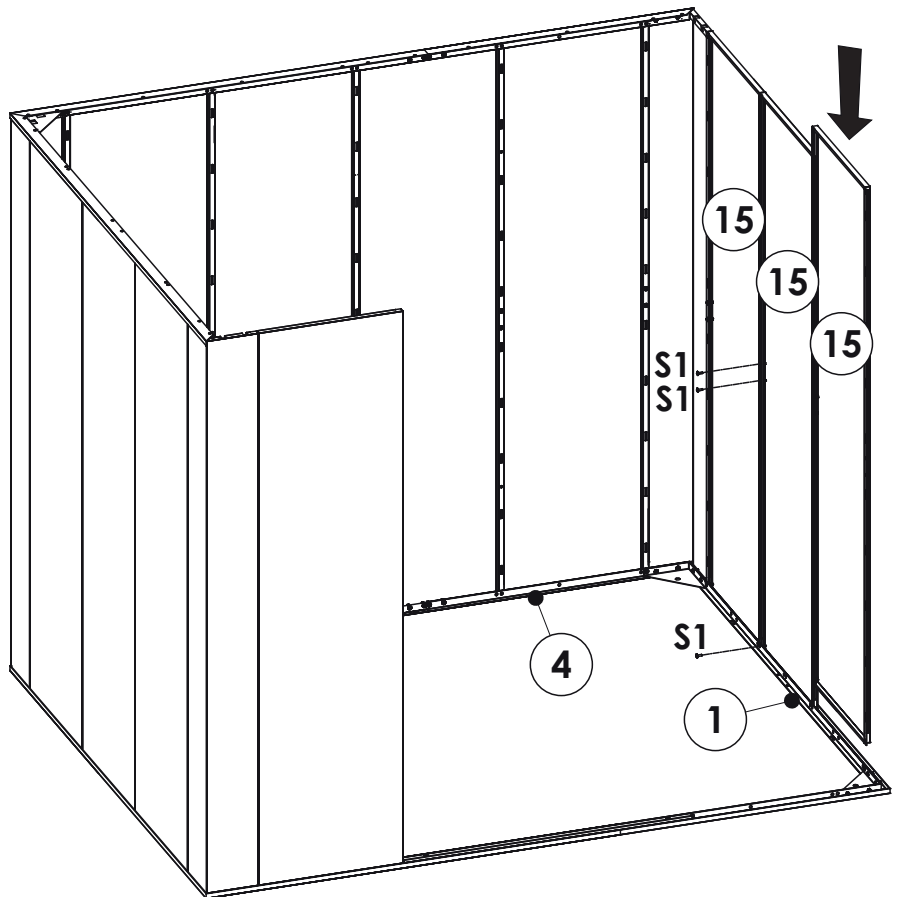
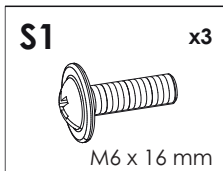

28

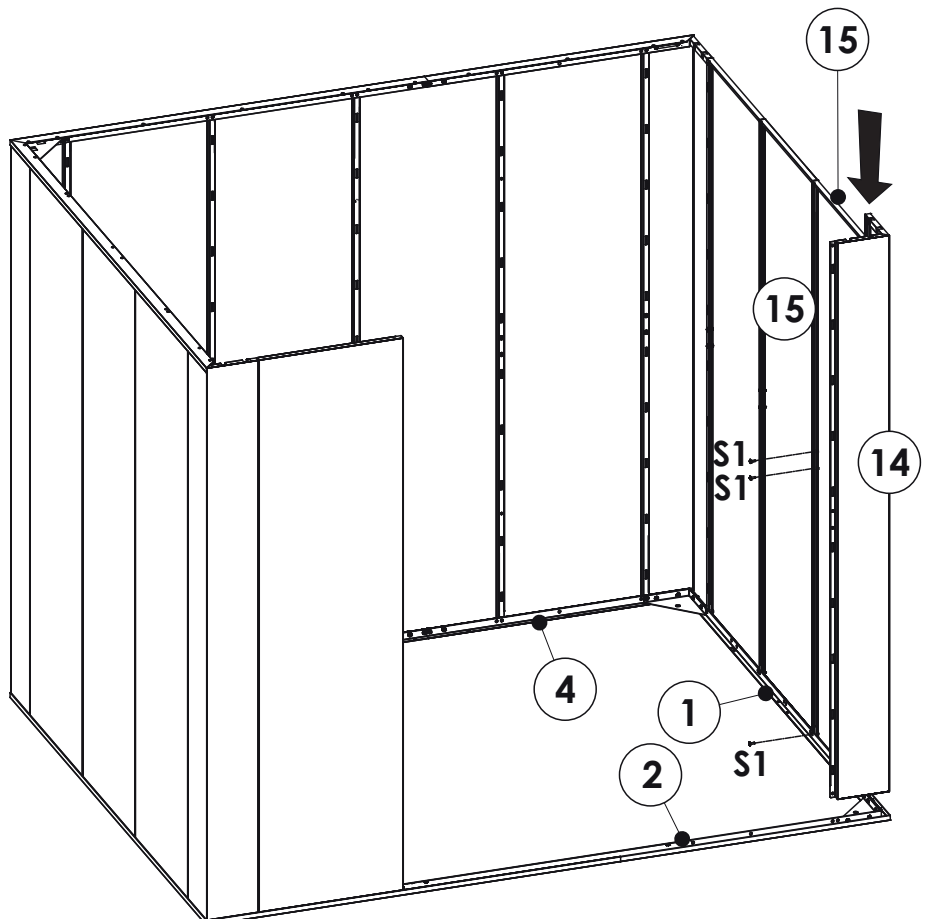
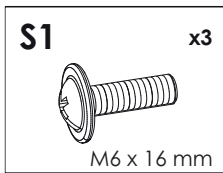

29

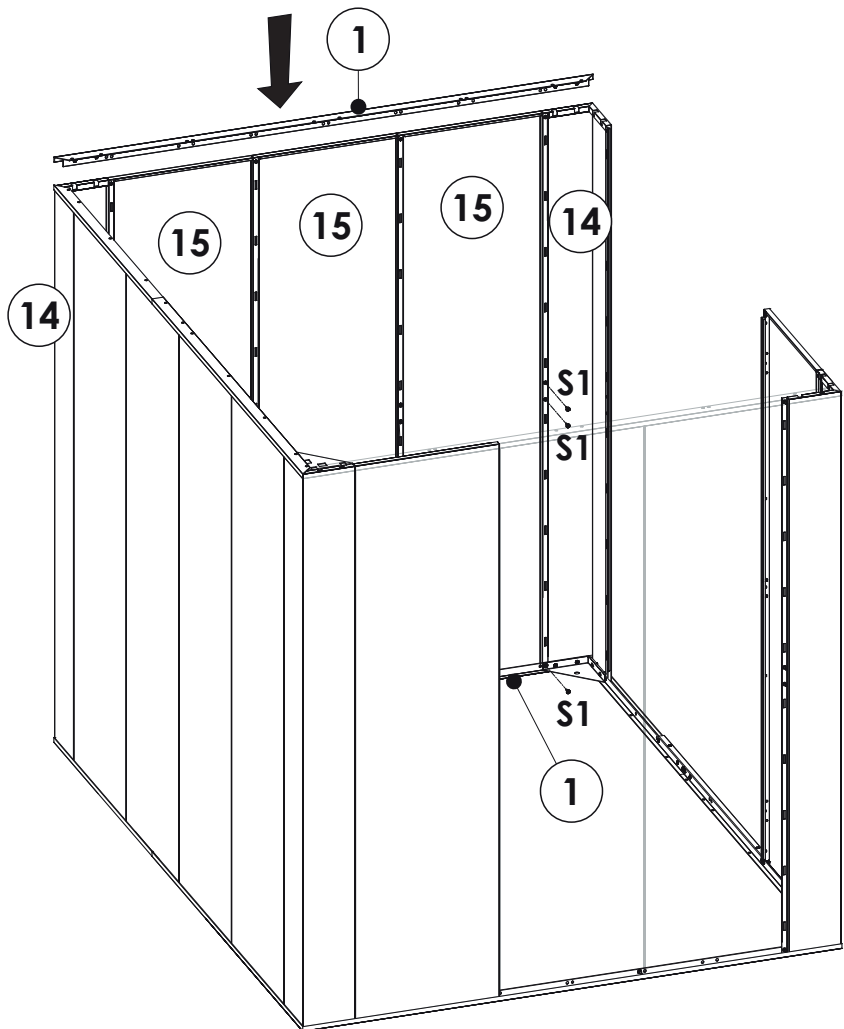
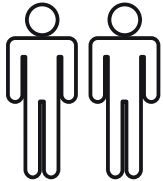
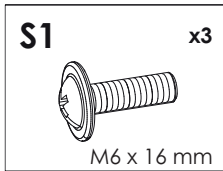

30

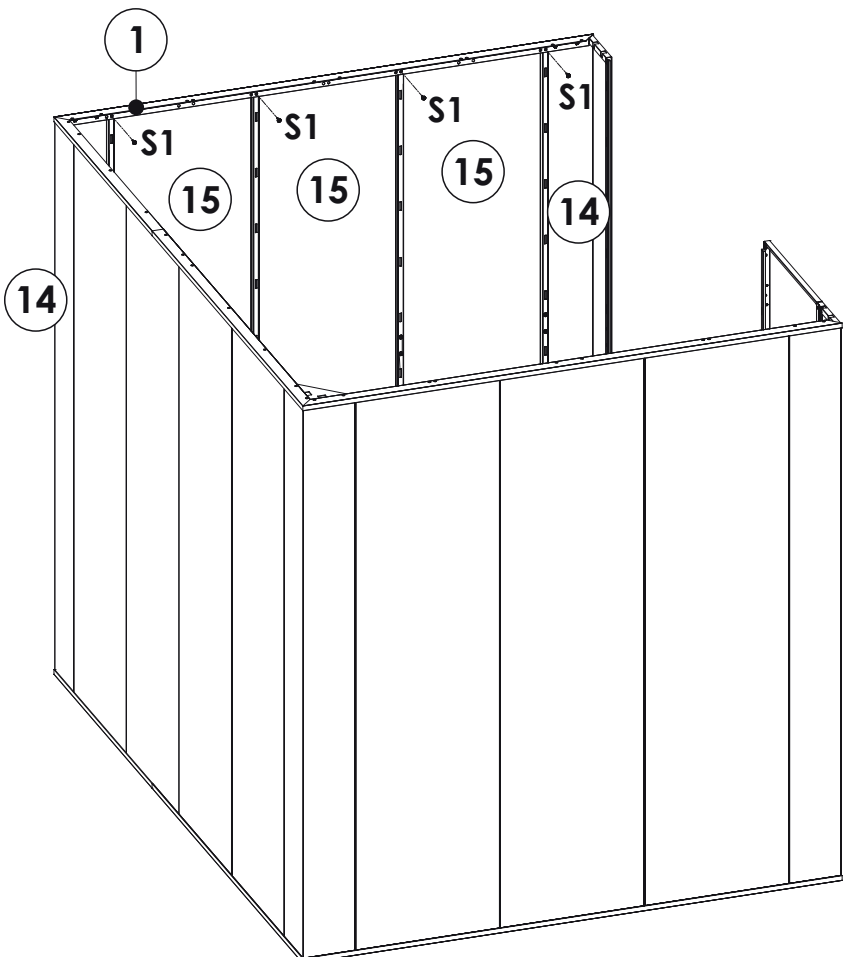
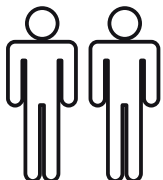
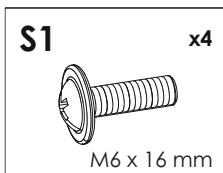

31

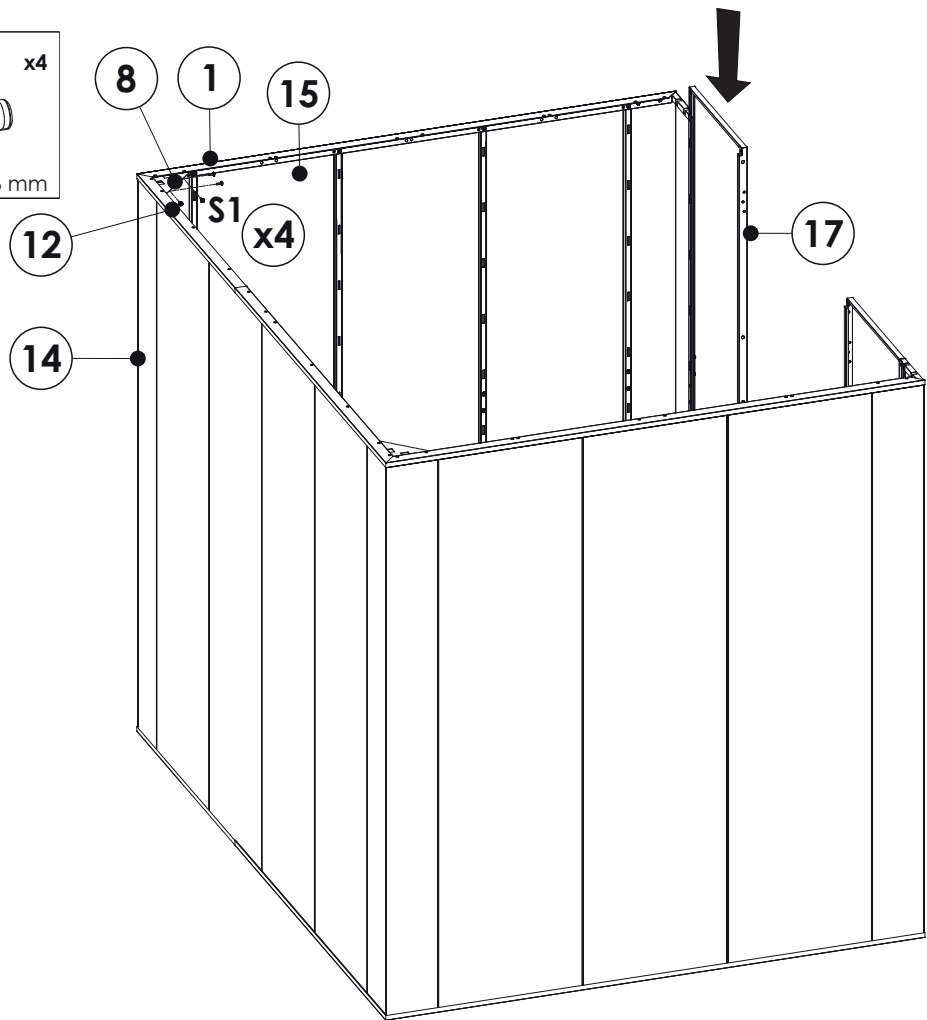
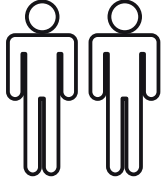
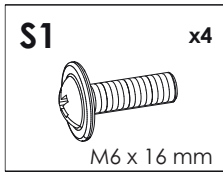

32

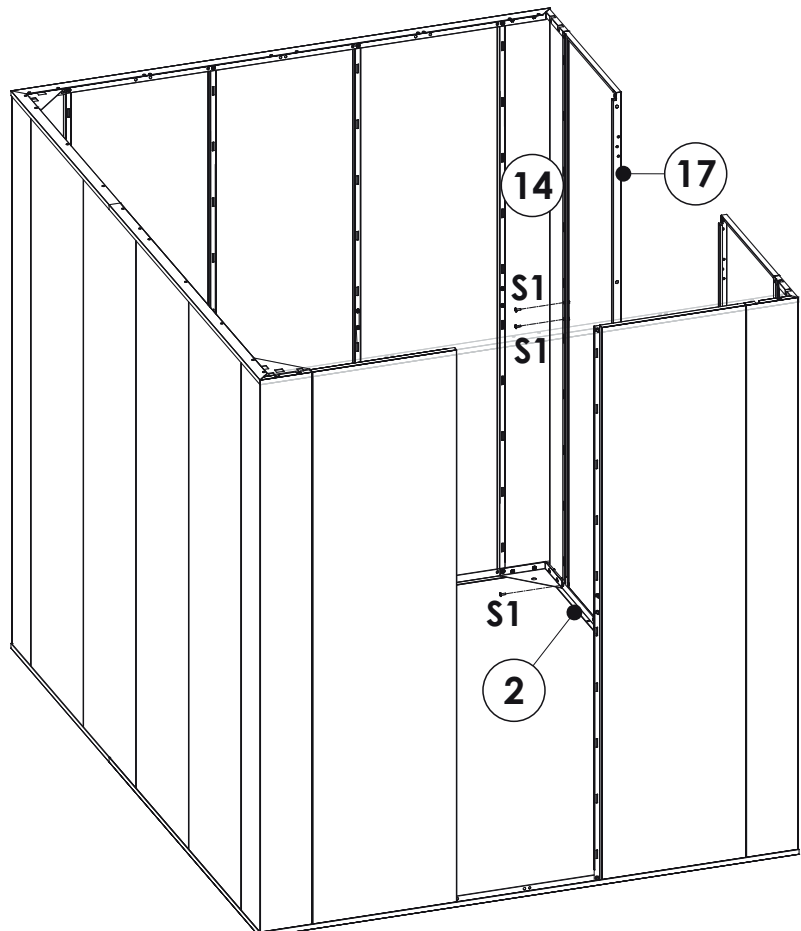
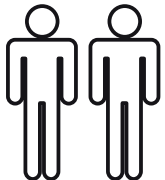
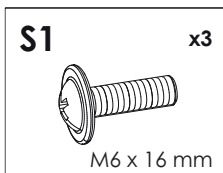

33

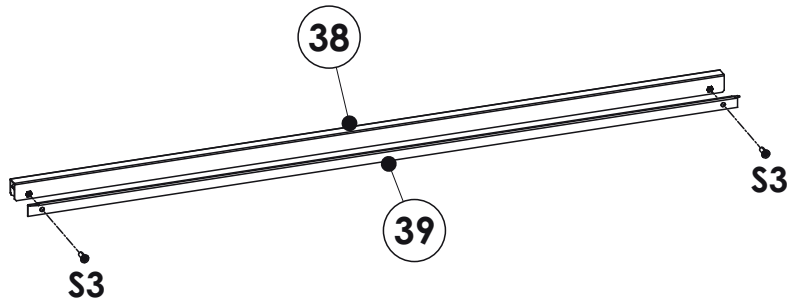
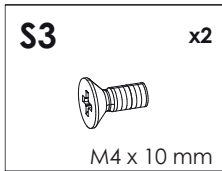

34

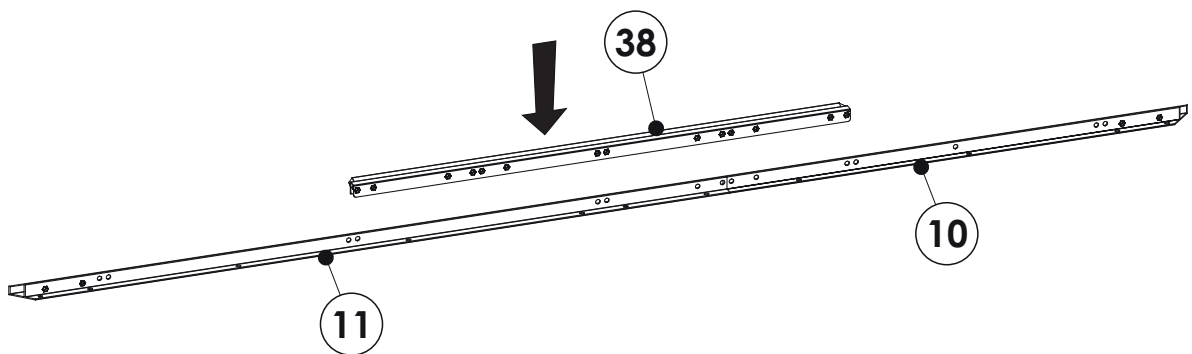

35

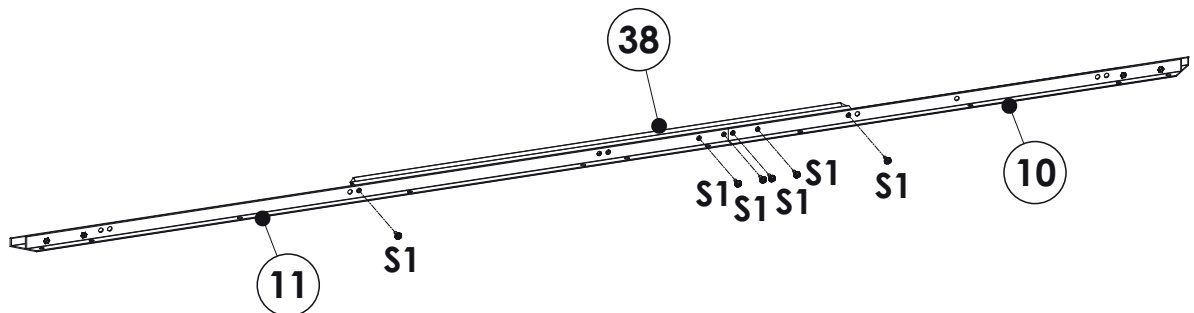
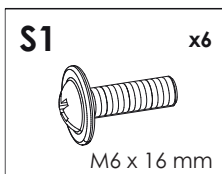

36

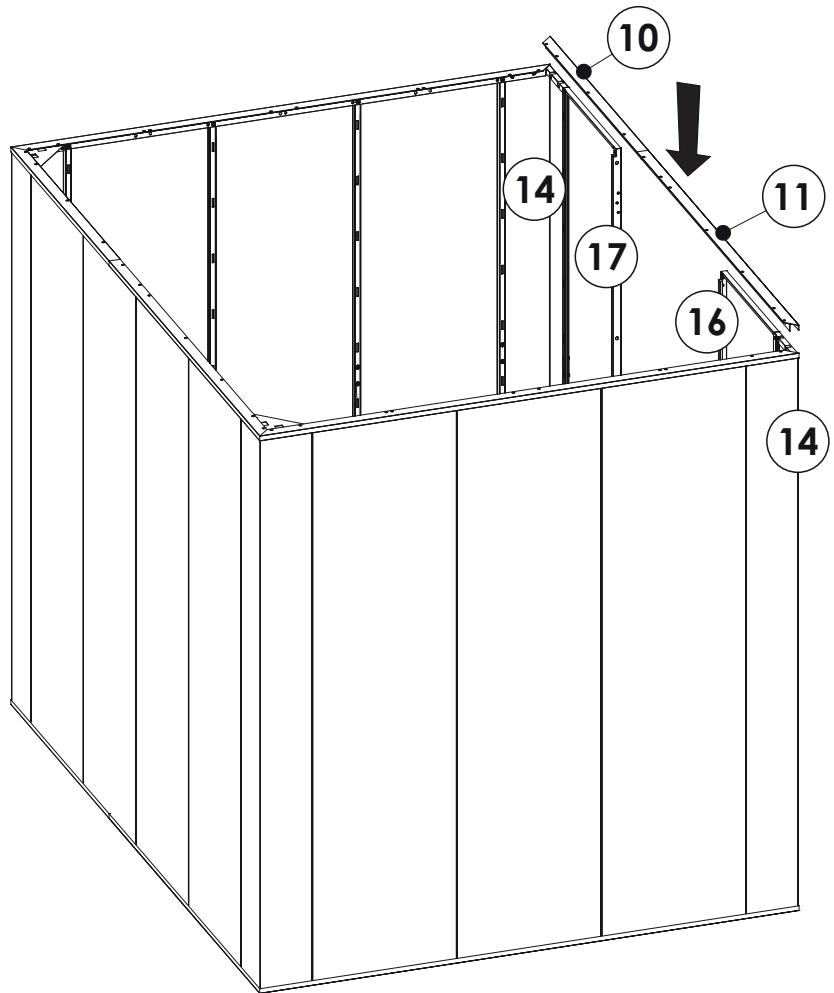

37

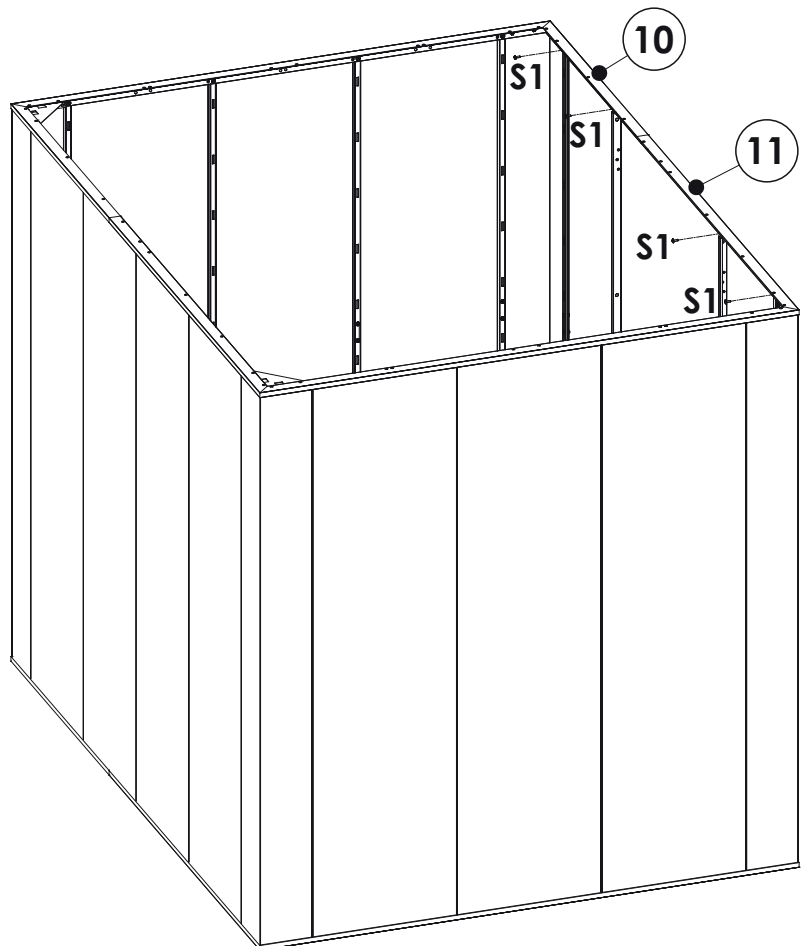
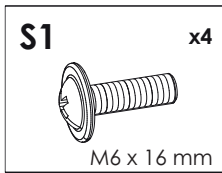

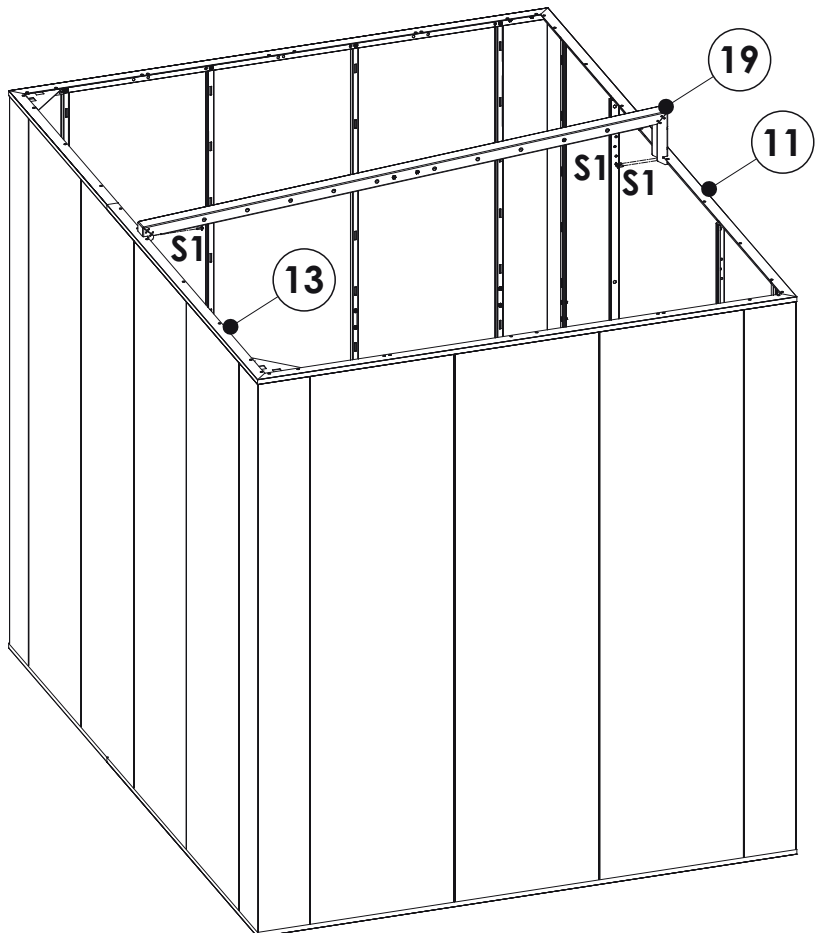
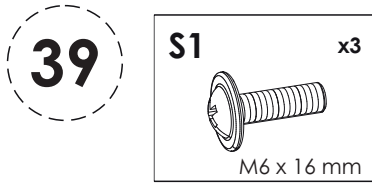
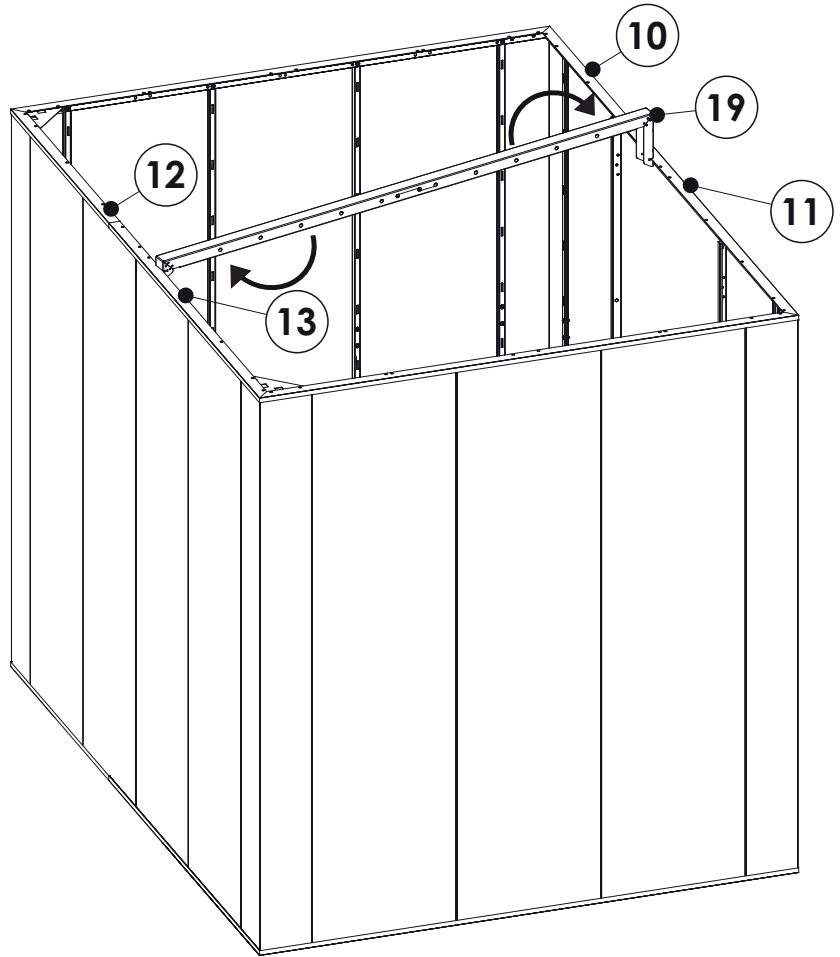
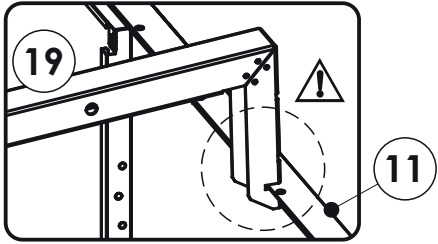
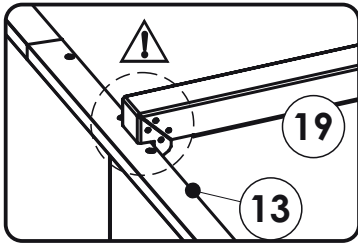

40

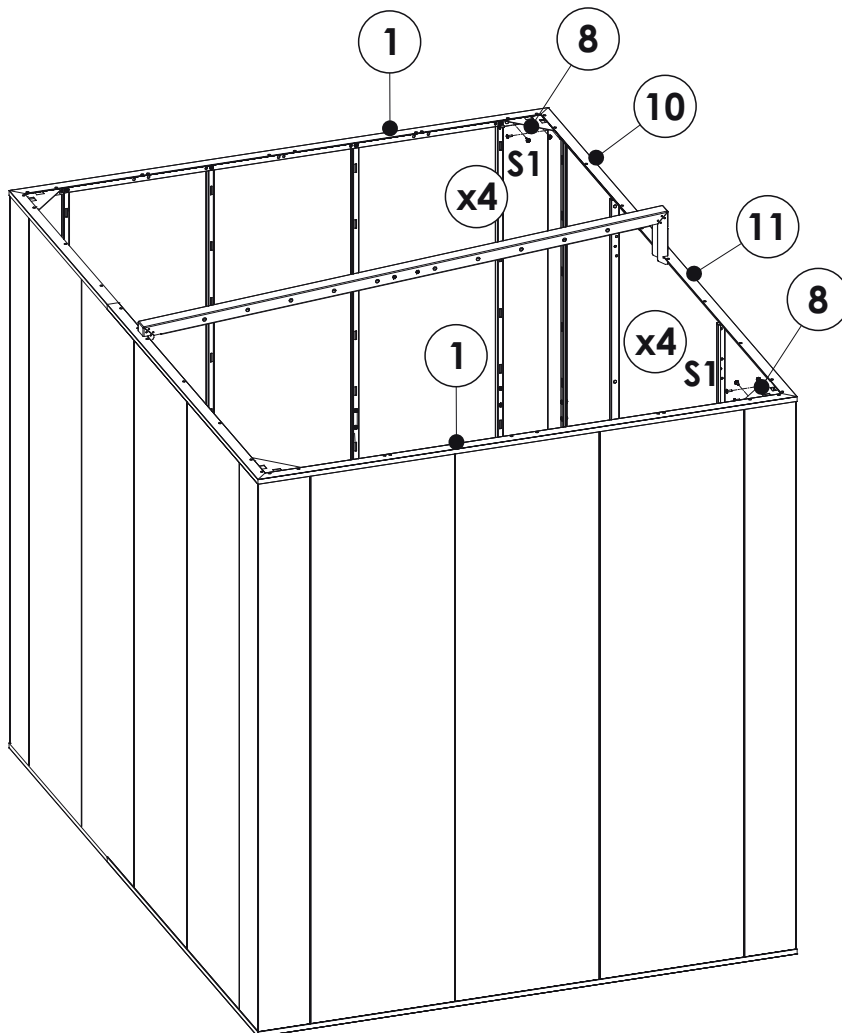
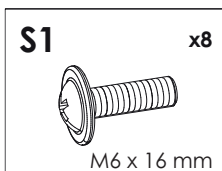

41

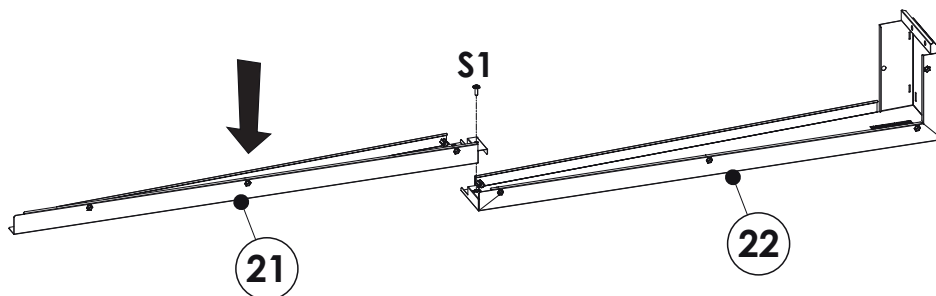
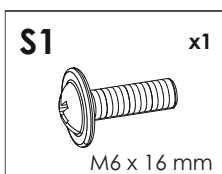

42

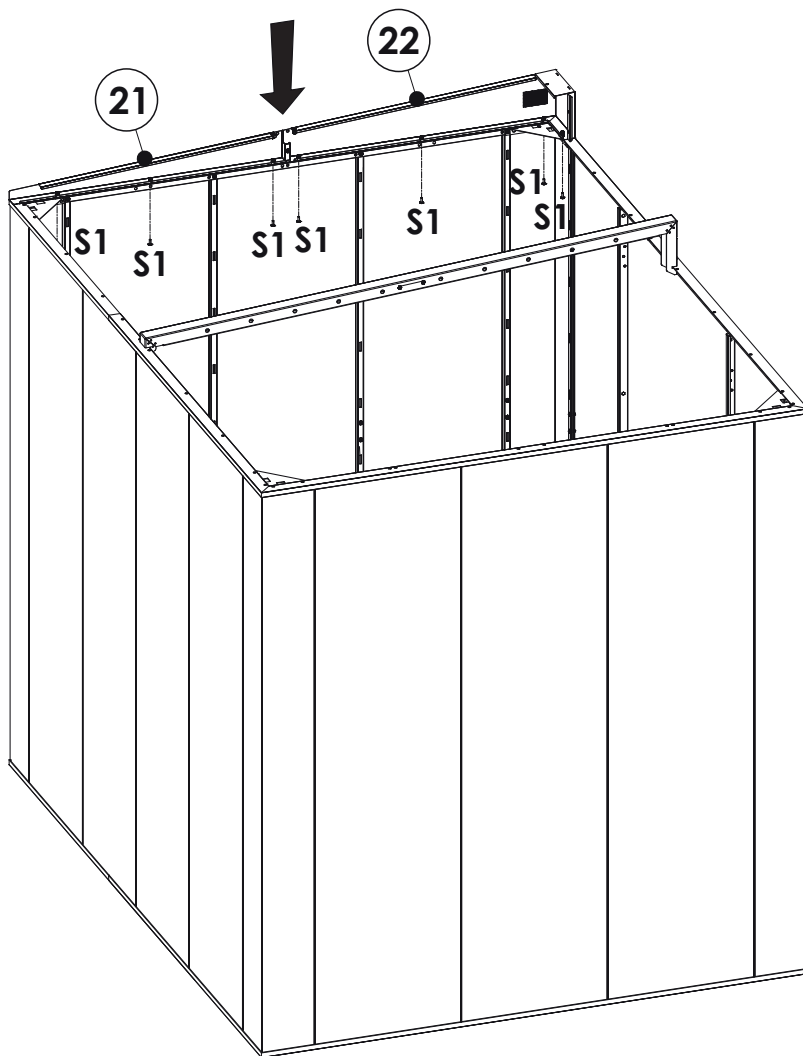
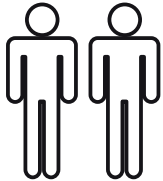
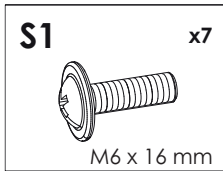

43

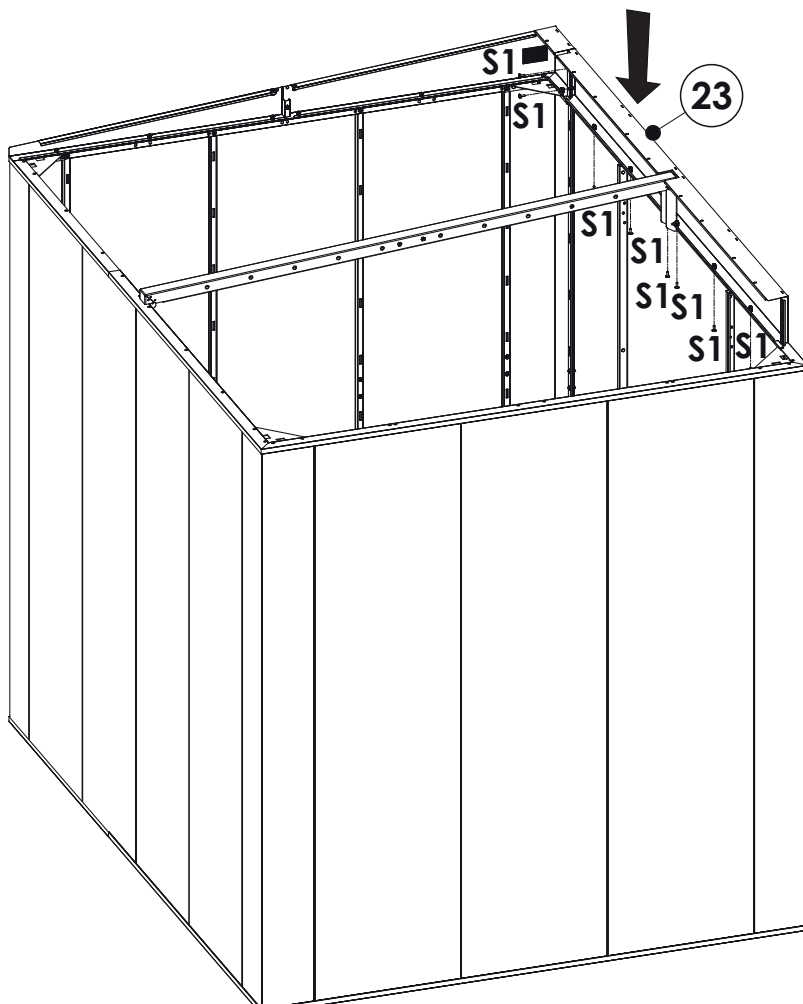
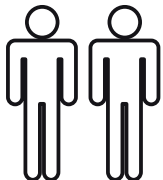
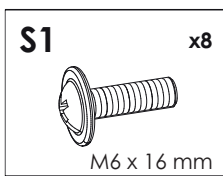

44

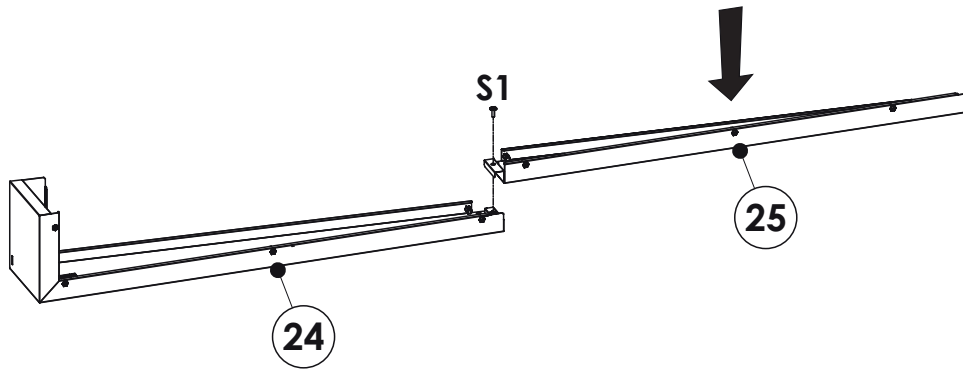
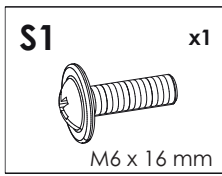

45

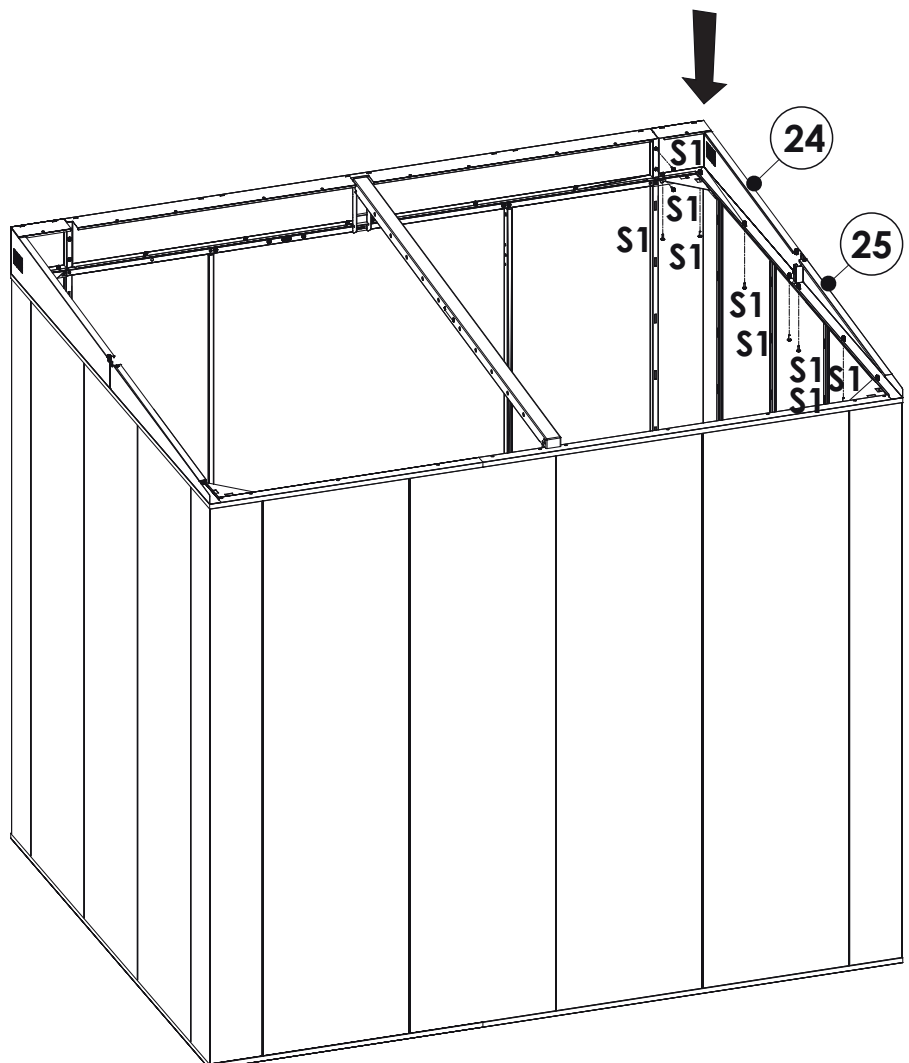
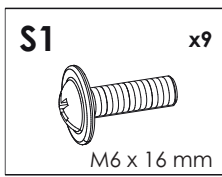

46

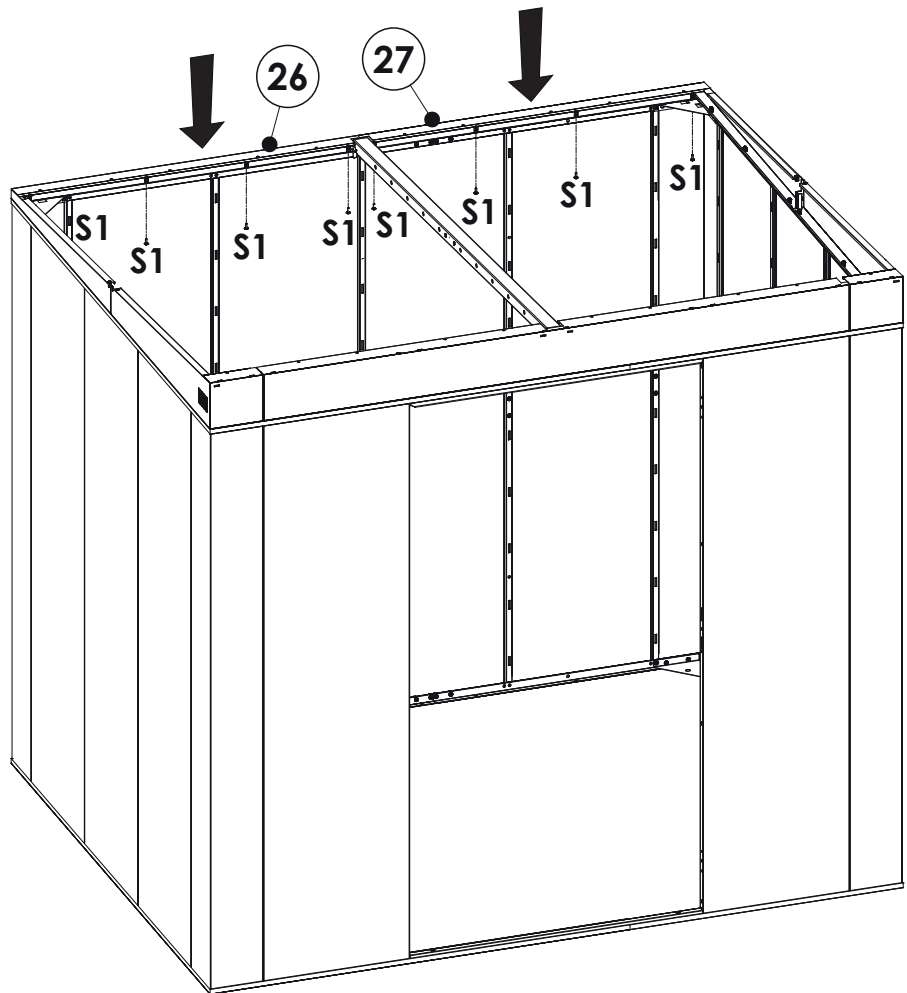
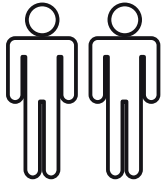
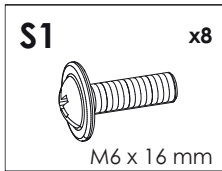

47

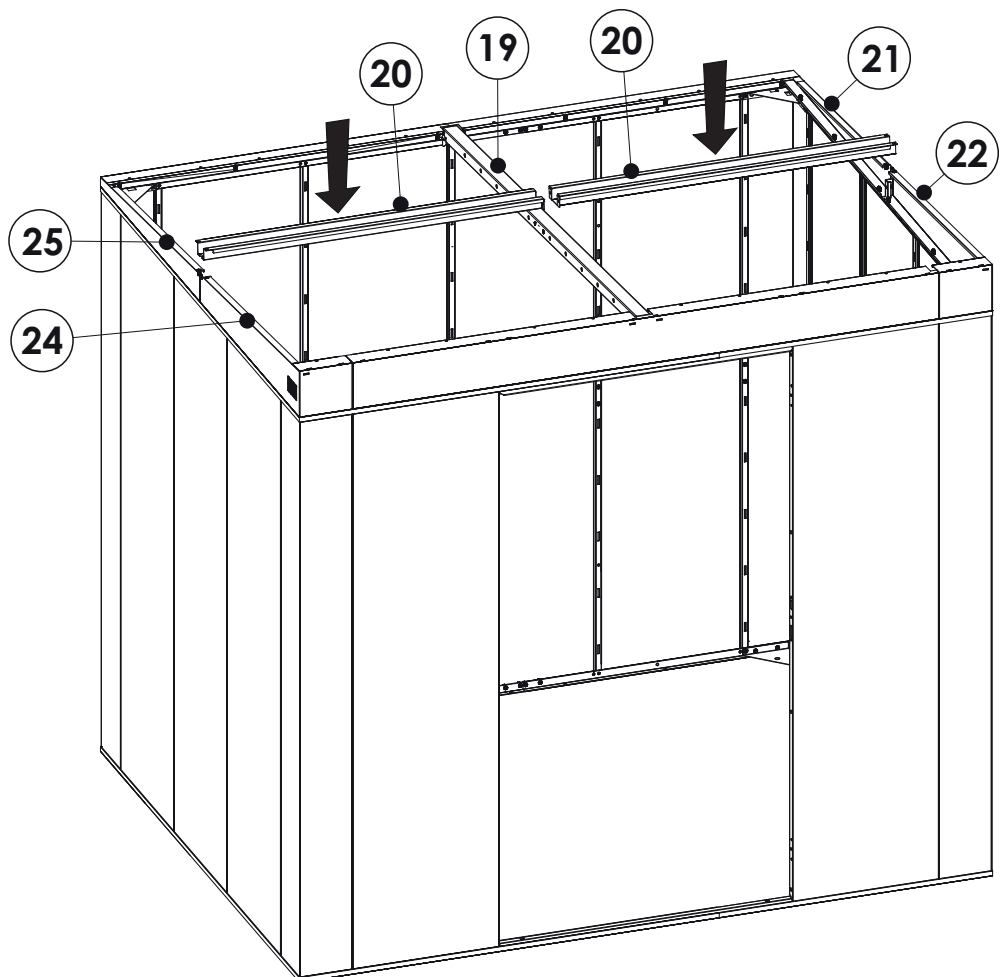
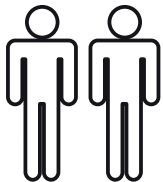

48

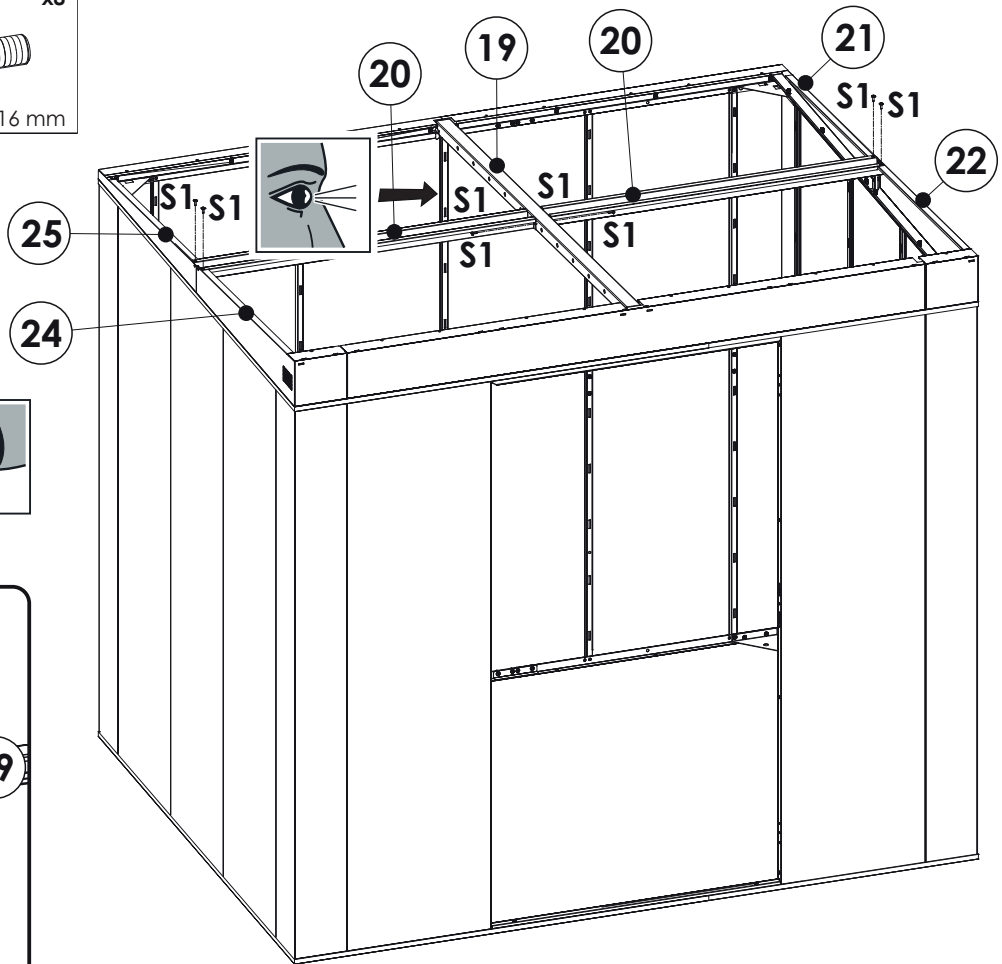
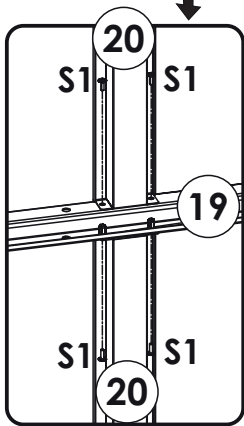
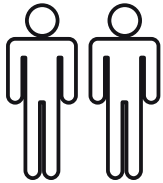
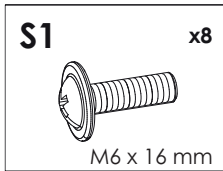

49

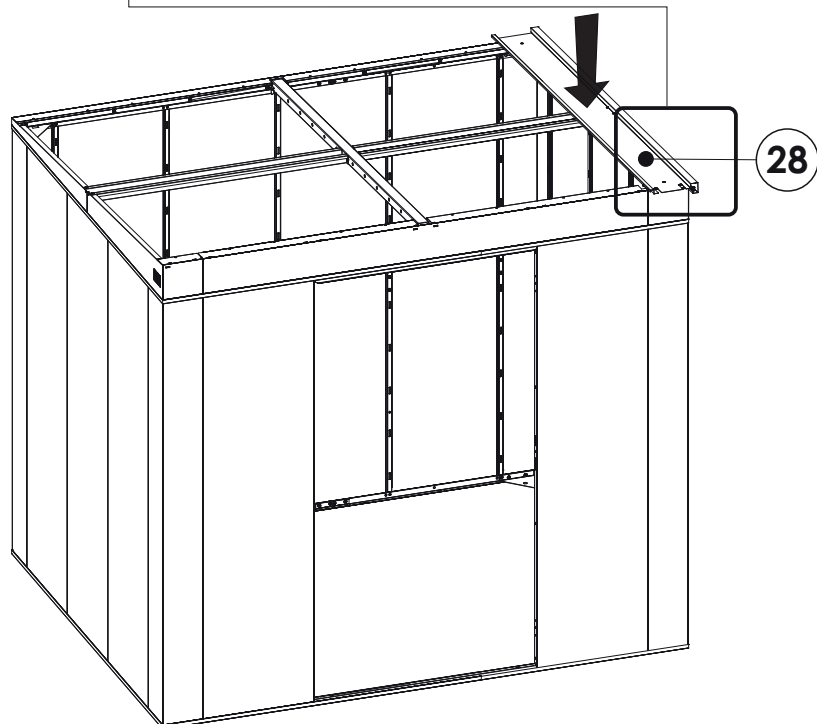
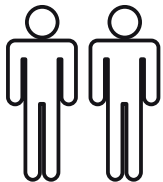
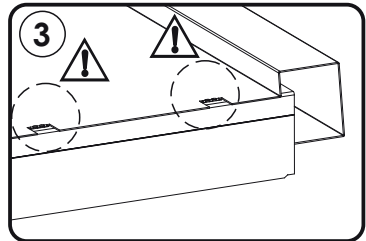
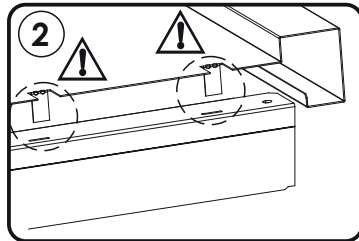
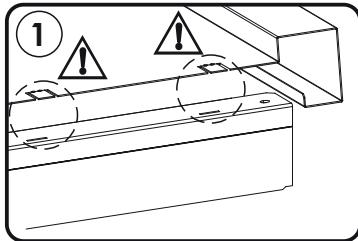

50

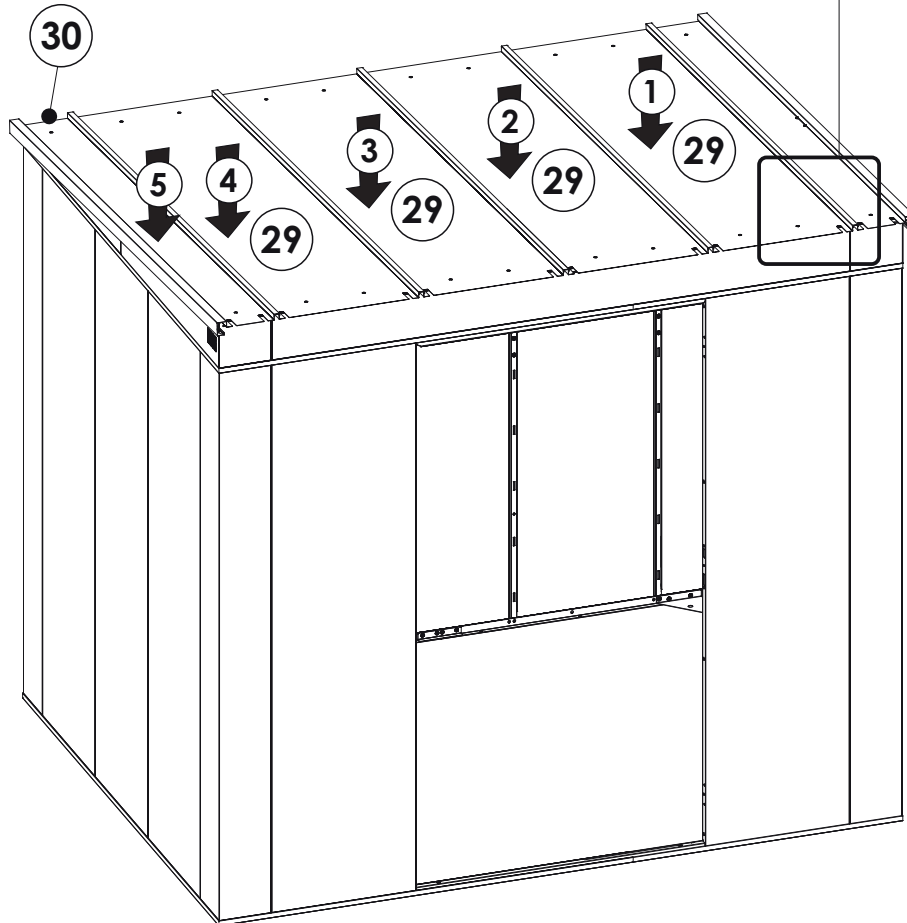
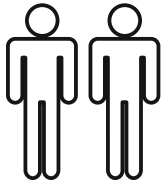
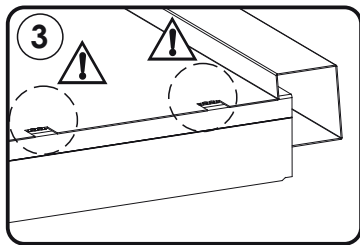
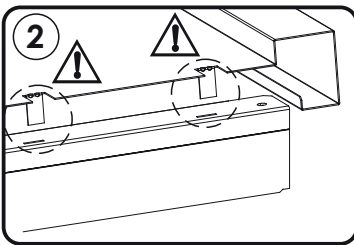
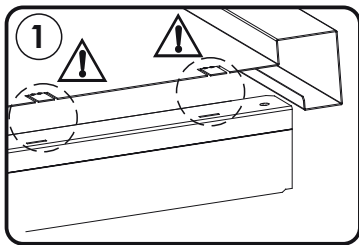

51

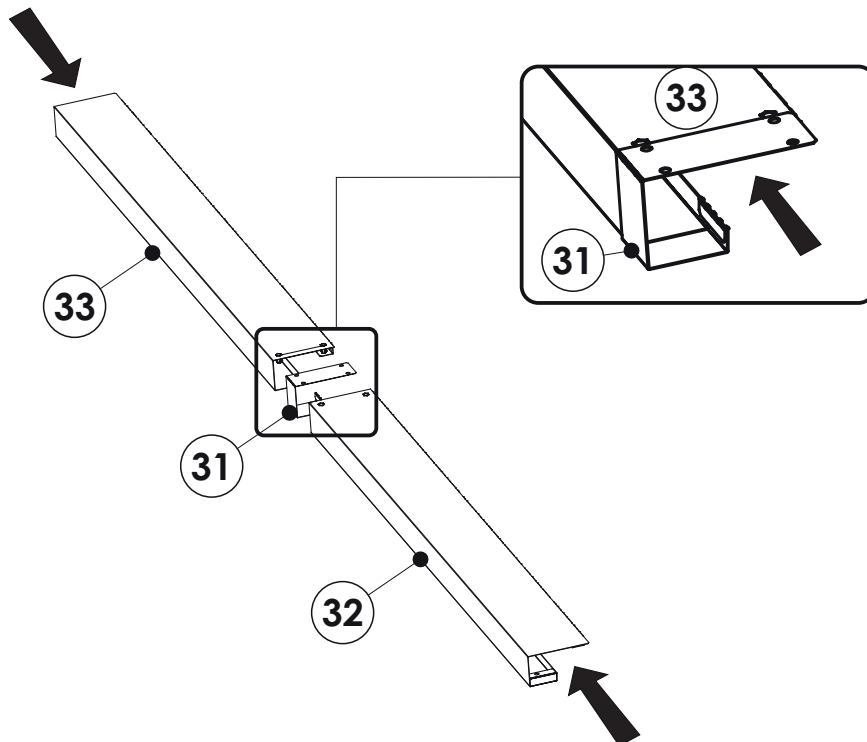

52

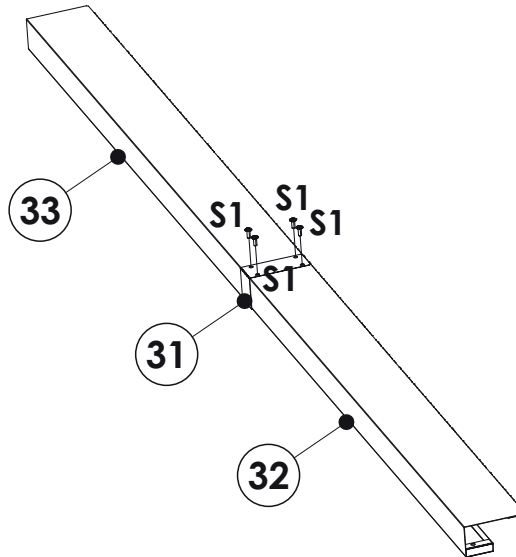
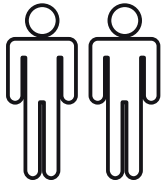
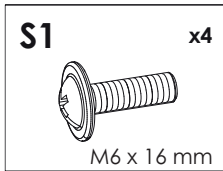

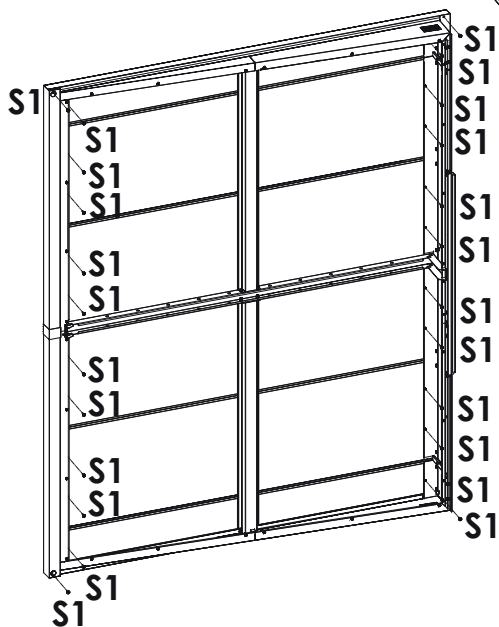
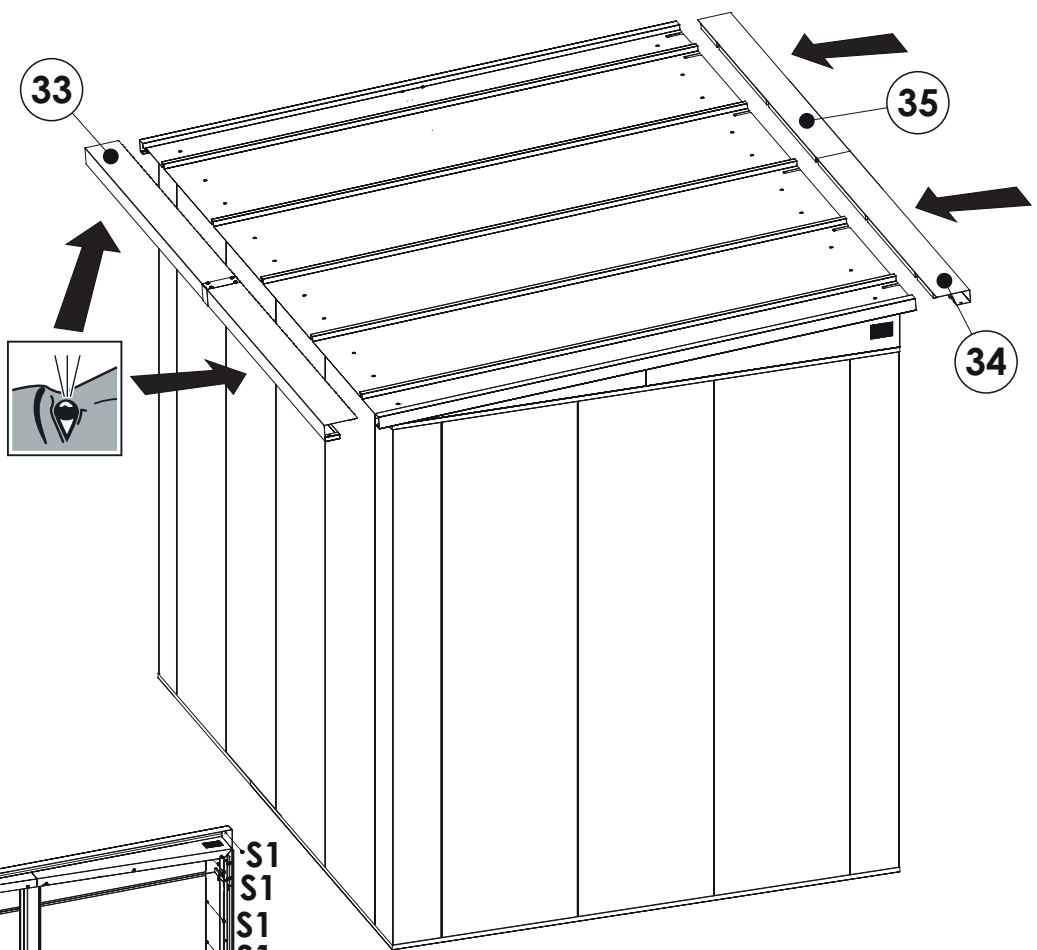
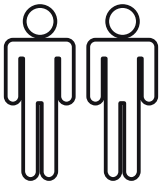
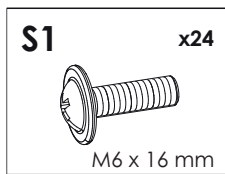

53

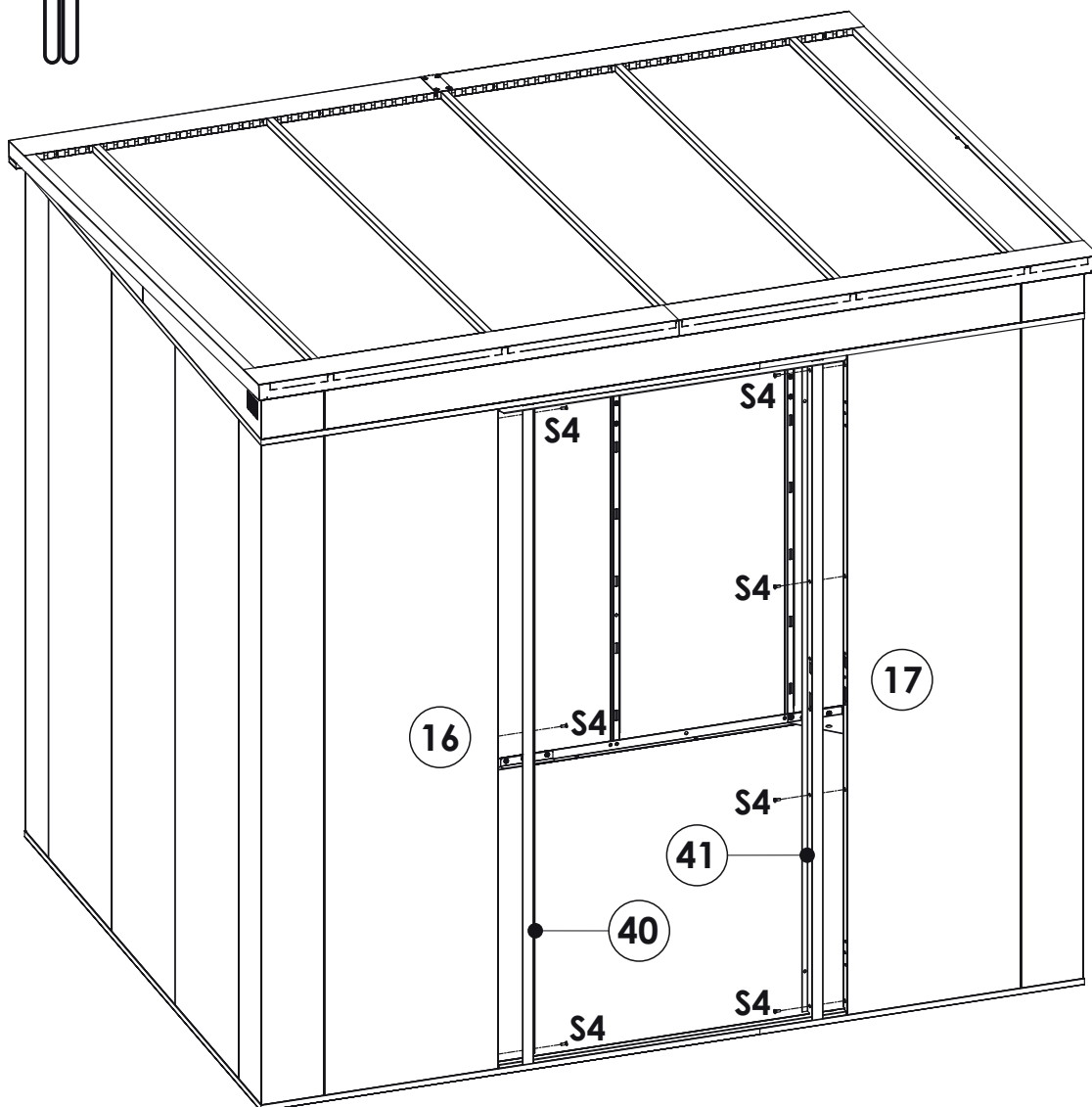
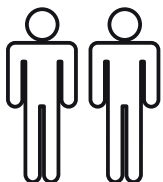
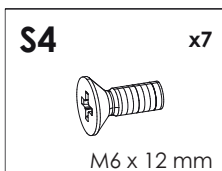

54



55

S3  M4 x 10 mm	x2	S4  M6 x 12 mm	x2	S5  x2
--	----	--	----	--

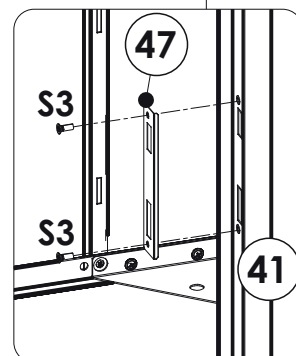
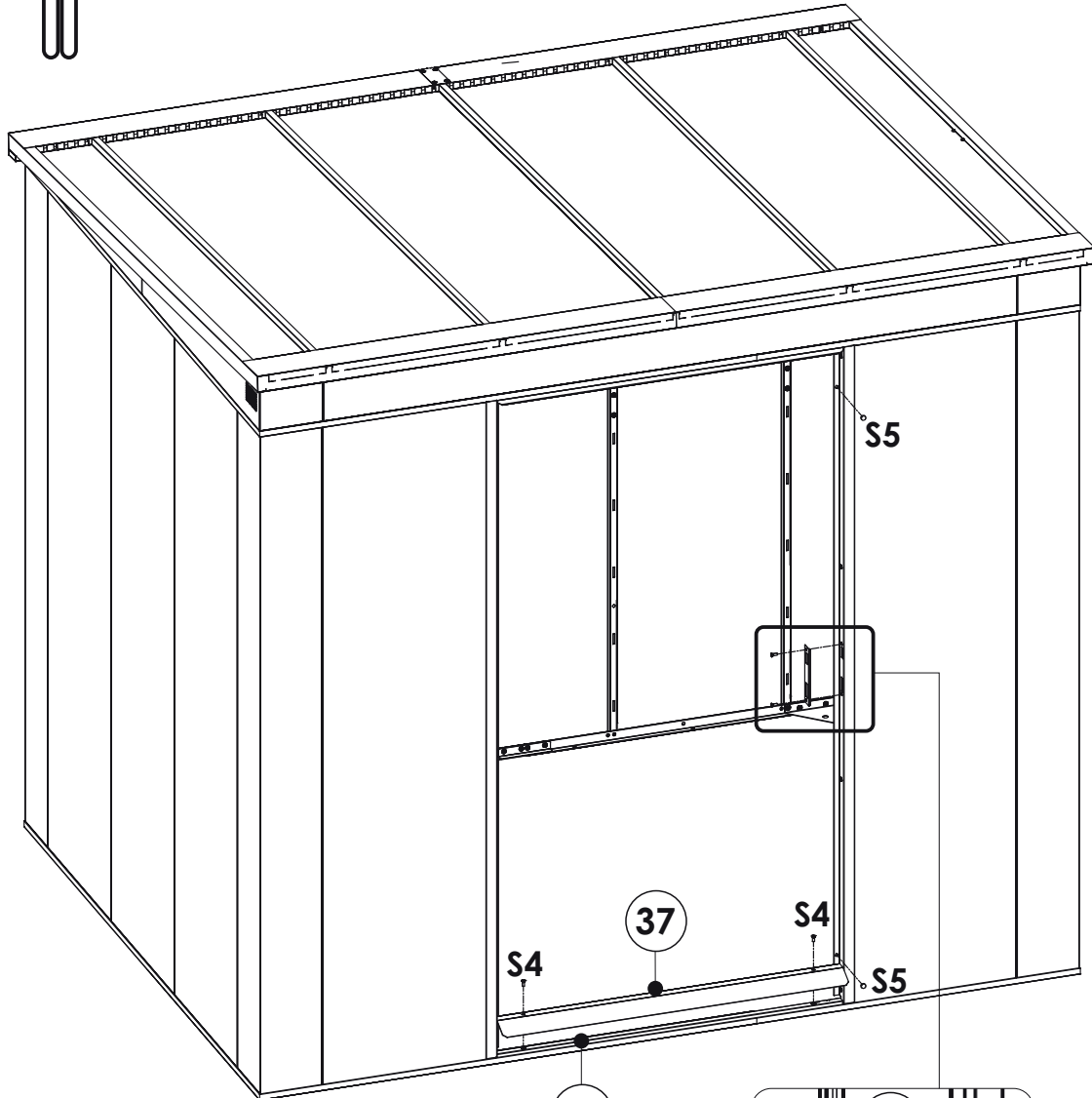
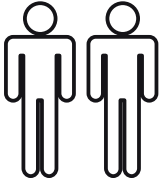

56

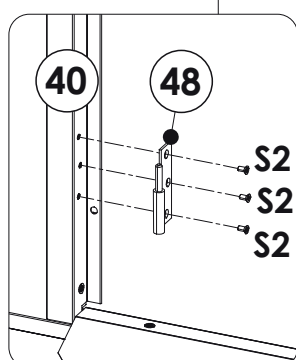
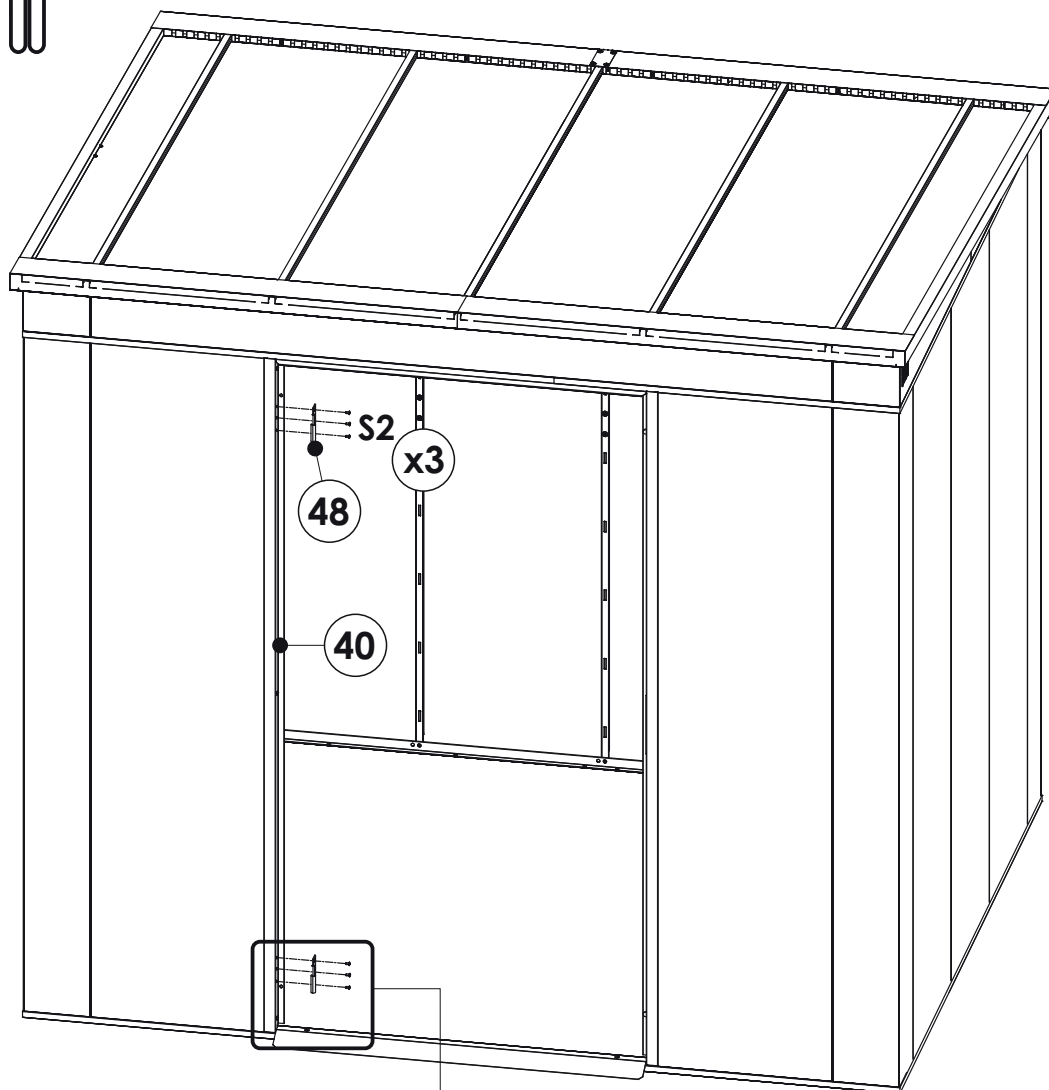
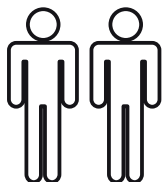
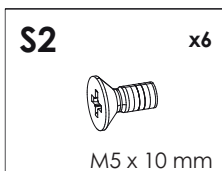

57

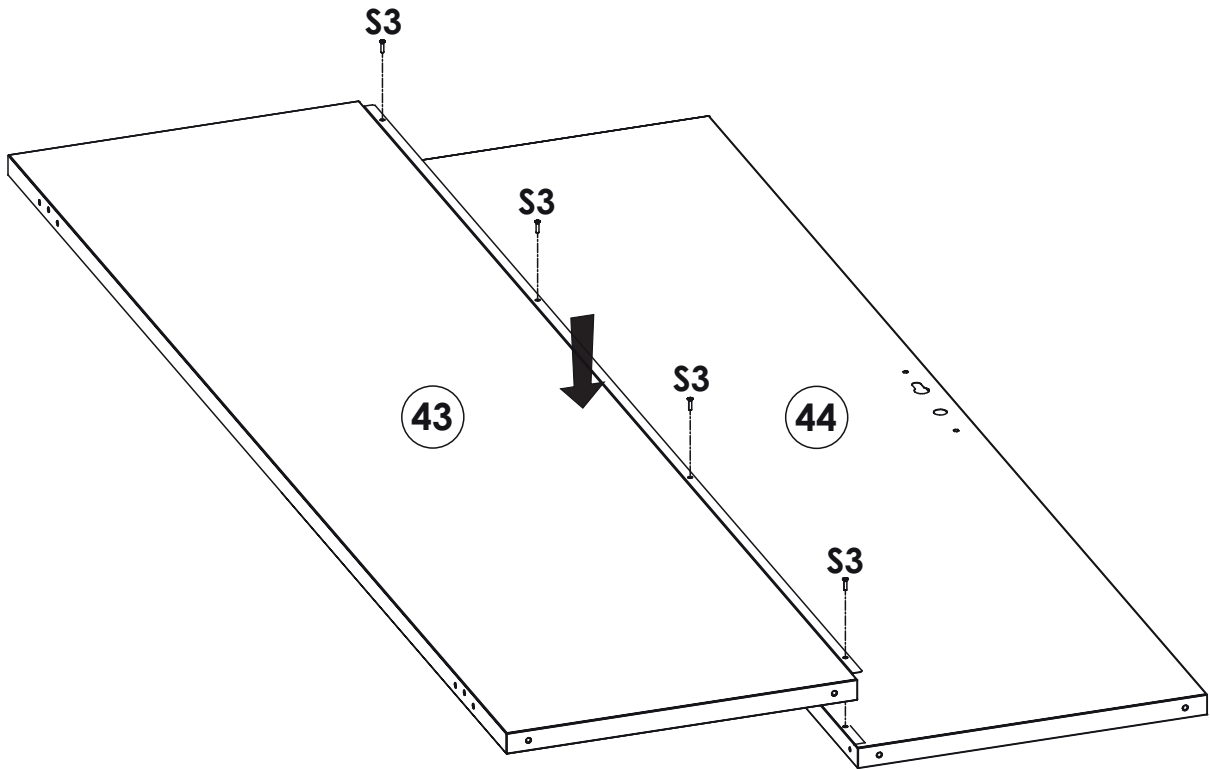
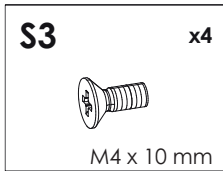

58

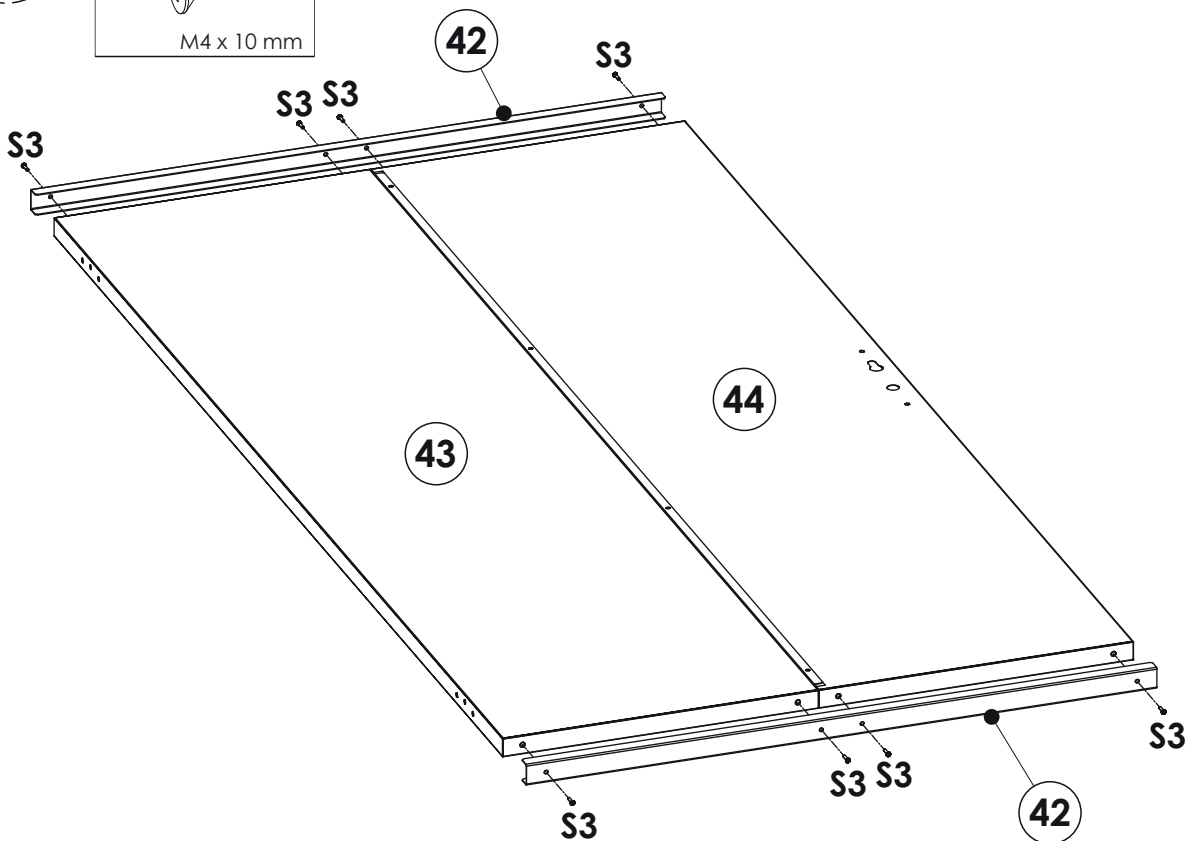

59

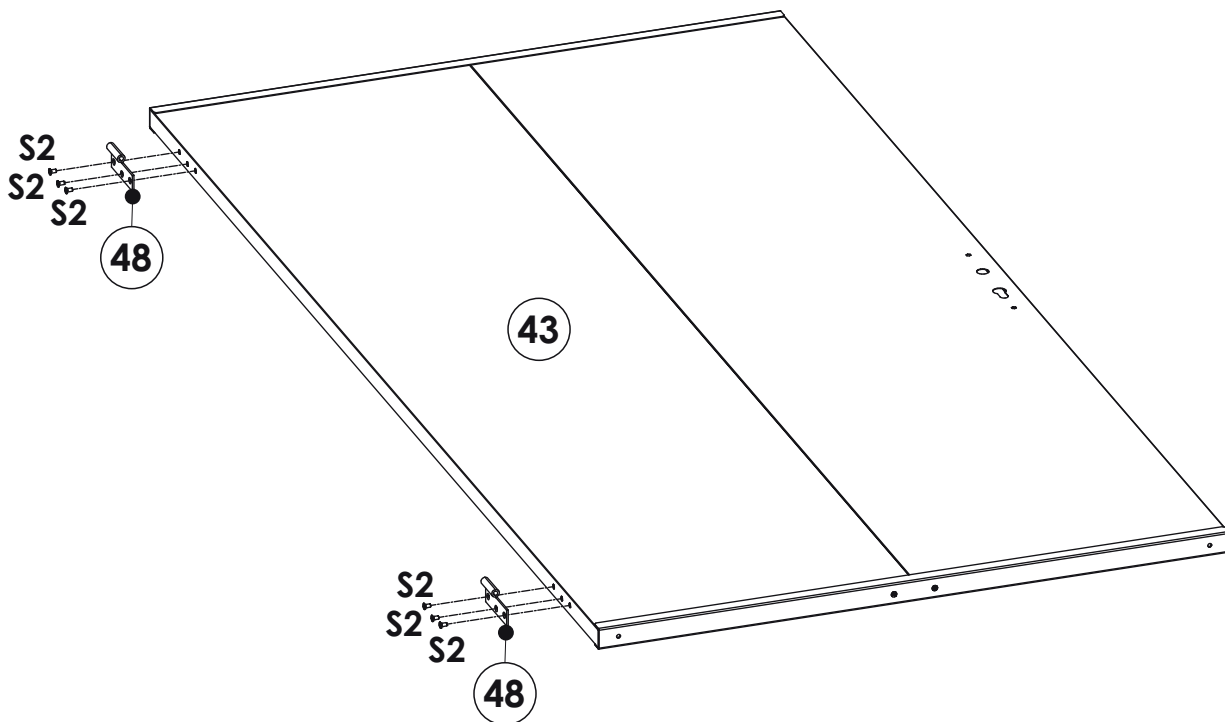
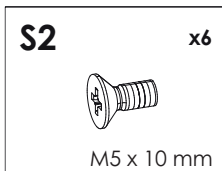

60

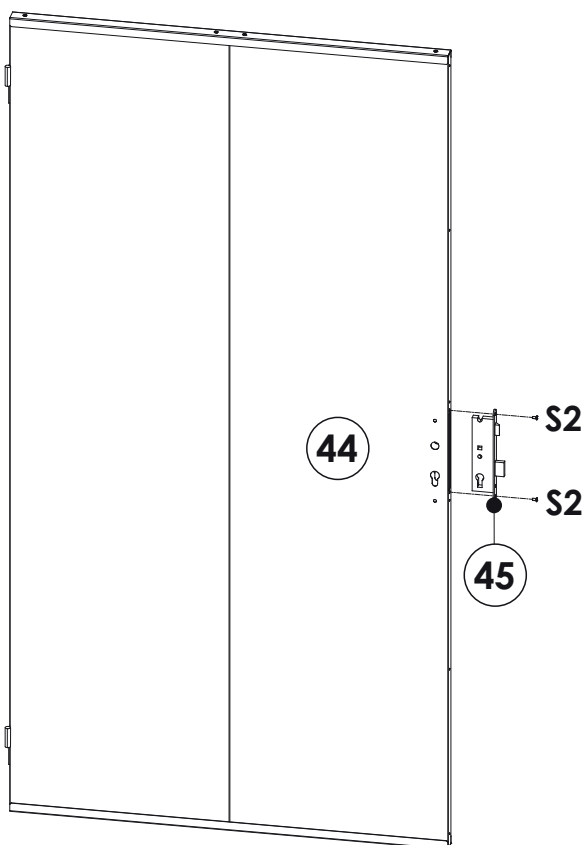
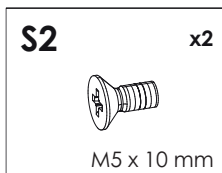

61

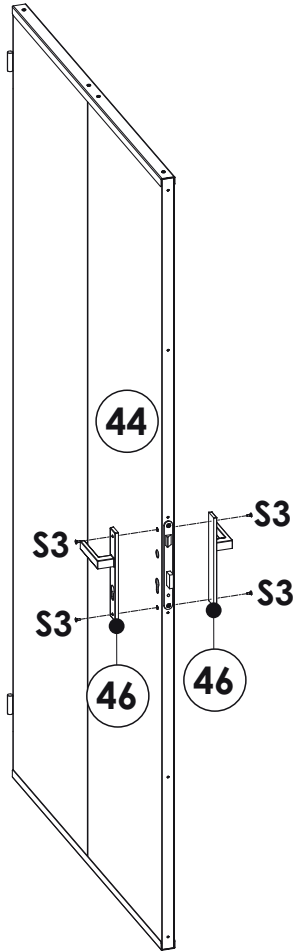
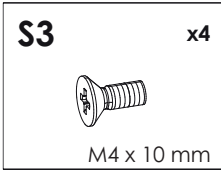

62

